

EA250 analogue amplifier



product description

The EA250 analogue amplifier is a high-performance signal conditioner designed for strain-gauge based sensors, including load cells, force sensors, torque and pressure sensors. It converts the strain gauge input into a voltage or current output, offering a wide bandwidth and a large input signal range.

The conditioned output signal can be selected from 0-20 mA, 4-20 mA, 0-10 V, 0-5 V, ± 5 V or ± 10 V. The EA250 can provide excitation for up to four 350 Ω strain gauge bridges.

The EA250 is housed in a robust water-resistant case protected to IP65. The case is bulkhead mountable and CE compliant.

applications

Silo weighing

Data acquisition systems

Process control

PLC interfaces

key features

1 - 5 kHz adjusted filter for test & measurement applications

Selectable sensitivity from 0.1 to 30 mV/V

Suitable for almost any analogue application

Very stable bridge excitation

High frequency filtering

Selectable analogue outputs

Environmental protection to IP65



RoHS
compliant



specifications

parameter	units	min	typical	max
Power supply:- (110/230Vac) 50 - 60Hz	V AC	99/198	110/230	126/253
Power supply DC :-	V DC (Note: 1)	18	-	24
Power supply IS12/24 - Isolated	V DC	9	-	36
Power supply current DC :- (depends on loading)	mA	50	90	200
Bridge excitation (10 V range)	V	9.75	10	10.25
Bridge excitation (5 V range)	V	4.85	5	5.15
Bridge resistance	Ω	85	-	
Bridge sensitivity (Switchable)	mV/V	0.06	-	30
Gain adjustment (Pot - fine adj.)	mV/V (Note: 2)	0.06	-	1.0
Offset adjustment (Pot - fine adj.)	%FR (FR=Full Range)	-1.25	-	+1.25
Offset adjustment (Switchable - coarse adj)	%FR	± 1.25	-	± 80
Output load (Voltage output)	mA		-	2
Output load (Current output)	Ω	0	-	500
Bandwidth (No filter and > 2mV/V) - 3dB point	Hz	DC	-	6000
Filter cut-off (Switchable ranges) - 3dB point	Hz	1	-	5000
Zero temperature coefficient at 2.5mV/V)	%FR/ °C at 2.5mV/V FR	-	0.002	-
Span temperature coefficient	%FR/ °C	-	0.007	-
Linearity	%FR	-	0.03	-
Gain stability -1st 1000 Hours	%FR	-	0.2	-
Gain stability - 2nd 1000 Hours	%FR	-	0.1	-
90 day Offset stability	μ V	-	3.3	-
Output load stability gain (0 - 100%)	%FR	-	-	0.01

Output load stability offset (0 - 100%)	%FR	-	-	0.01
Power supply rejection gain (0 - 100%)	%FR	-	-	0.01
Power supply rejection offset (0 - 100%)	%FR	-	-	0.01
Operating temperature range	°C	-10	-	50
Storage temperature range	°C	-20	-	70
Humidity	%	-	-	95

Note:1 18V max at full load.

Note:2 Depends on sensitivity settings

Output Options Set by On-Board Switch

±10V, ±5V, 0-10V, 0-5V, 0-20mA, 4-20mA

Connections

Field screw terminals - 2.5mm² rising clamp

Enclosure

ABS case 160 x 80 x 55 sealed to IP65 fitted with 3 off cable glands

Controls

Gain pot, Offset pot, Coarse gain switches, Coarse offset switches, Filter cut-off switches, Output mode switch

Environmental

CE Environmental Approvals

European EMC Directive 2004/108/EC, Low Voltage directive 2006/95/EC

product dimensions (mm)

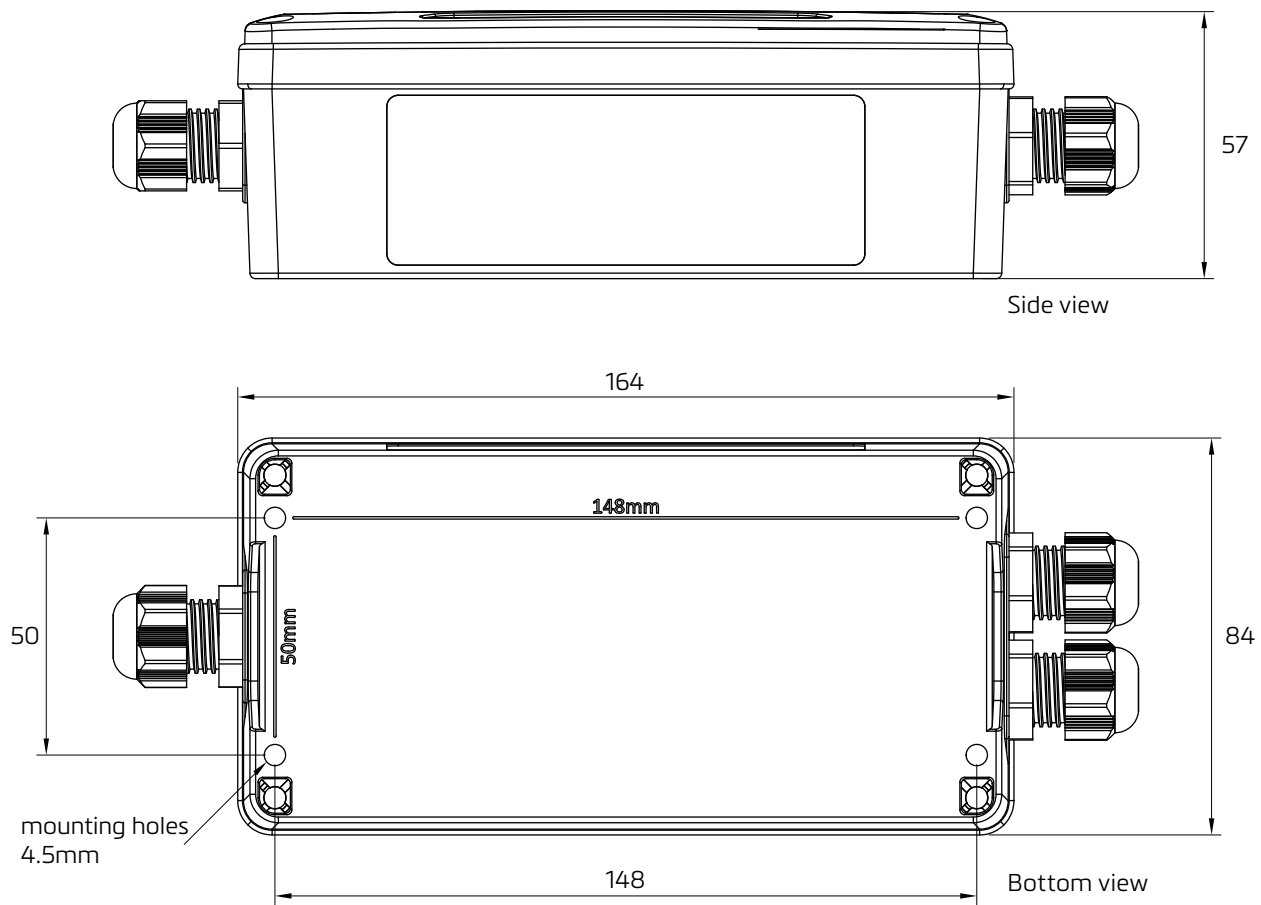

IP67 ABS field case fitted with 3 M16 cable glands
Cable diameter: 4mm (0.16") to 7mm (0.27")

Specifications and dimensions are subject to change without notice.