

PC52 single point load cell

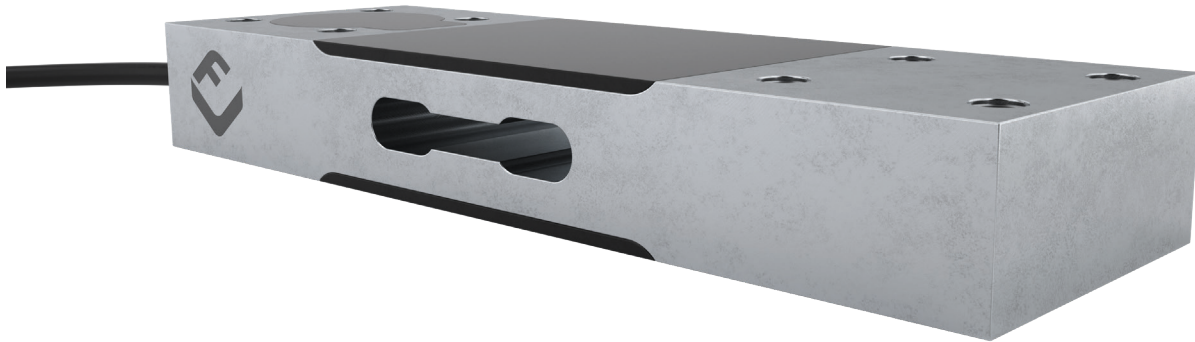

product description

The PC52 is a very low profile, single capacity, single point load cell, ideal for applications where scale overall height needs to be minimised. Ideally suited for the construction of gas container monitoring scales with dimensions as large as 250 x 250mm. Constructed from aluminium and environmentally sealed with potting compound to ensure durability.

applications

Bench scales, gas container scales.

key features

Aluminium construction

Environmentally sealed by potting to IP67

Very low-profile design

For platform sizes of up to 250 x 250mm

Capacity of 100kg or 200kg

accessories

Compatible range of electronics



RoHS
compliant



specifications

Maximum capacity (E_{max})	kg	100, 200
Accuracy class		(GP)
Temperature effect on minimum dead load output (TC_0)	%*RO/10°C	± 0.2500
Temperature effect on sensitivity (TC_{RO})	%*RO/10°C	± 0.0700
Combined error	%*RO	± 0.0400
Creep error (30 minutes) / DR	%*RO	± 0.0400
Rated output (RO)	mV/V	2 ± 5%
Zero balance	%*RO	± 5
Excitation voltage	V	5...15
Input resistance (R_{LC})	Ω	1,150 ± 50
Output resistance (R_{out})	Ω	1,000 ± 100
Insulation resistance (100 V DC)	MΩ	≥ 10,000
Safe load limit (E_{lim})	%* E_{max}	200
Ultimate load	%* E_{max}	300
Safe side load	%* E_{max}	100
Maximum platform size; loading acc. OIML R76	mm	250 x 250
Maximum off centre distance at maximum capacity	mm	95
Compensated temperature range	°C	-10...+40
Operating temperature range	°C	-20...+65
Load cell material		aluminium
Sealing		potted
Protection according EN 60 529		IP67
Packet weight	kg	0.4



product dimensions (mm)

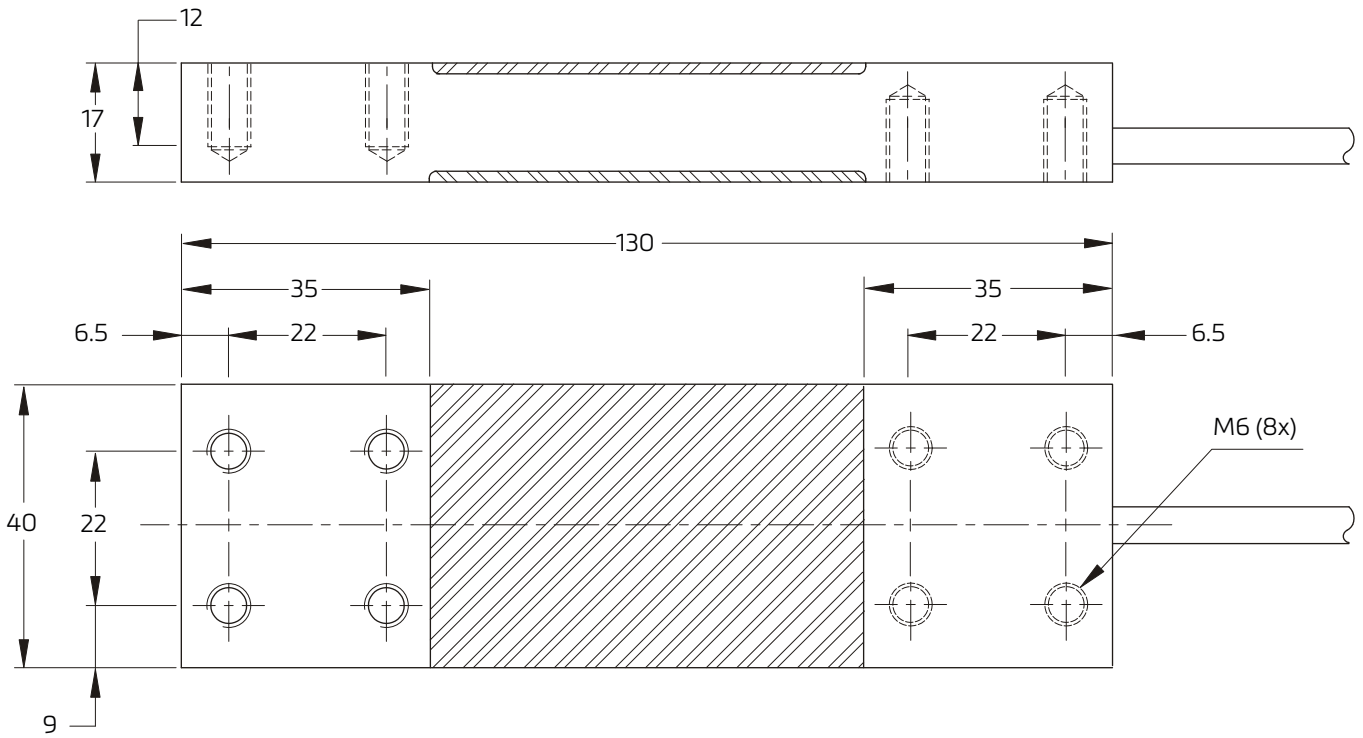

Mounting bolts M6 8.8; torque 10 Nm. Torque value assumes oiled threads.

wiring

The load cell is provided with a shielded, 6 conductor cable (AWG 26).

Cable jacket: polyurethane

Cable length: 0.315 m

Cable diameter: 5.8 mm

The shield is connected to the load cell body

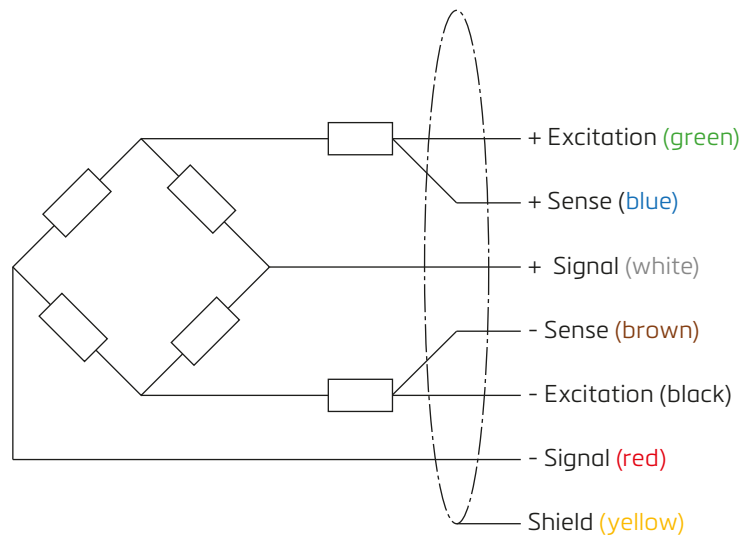

Specifications and dimensions are subject to change without notice.