

Installation Manual

Compression Load Cell PR 6201



Foreword

Must be followed!

Any information in this document is subject to change without notice and does not represent a commitment on the part of Minebea Intec unless legally prescribed. This product should only be operated/installed by trained and qualified personnel. In correspondence concerning this product, the type, name, and release number/serial number as well as all license numbers relating to the product have to be cited.

Note

This document is partially protected by copyright. It may not be changed or copied, and it may not be used without purchasing or written permission from the copyright owner (Minebea Intec). The use of this product constitutes acceptance by you of the abovementioned provisions.

Table of contents

1	Introduction.....	4
1.1	Read the manual.....	4
1.2	This is what operating instructions look like.....	4
1.3	This is what lists look like.....	4
1.4	This is what menu items and softkeys look like.....	4
1.5	This is what the safety instructions look like.....	4
1.6	Hotline.....	5
2	Safety instructions.....	6
2.1	General notes.....	6
2.2	Intended use.....	6
2.3	Initial inspection.....	6
2.4	Before operational startup.....	6
3	Recommendations for installation.....	7
3.1	Load cell and constrainer arrangement.....	7
3.2	Location of load cells and pivots.....	8
3.3	Additional lift-off protection.....	9
3.4	Selecting maximum capacity.....	9
4	Specifications.....	10
4.1	Equipment supplied with the load cell.....	10
4.1.1	Load cells PR 6201/52...54 (max. capacity 500 kg...50 t).....	10
4.1.2	Load cells PR 6201/15, /25, /35 and DB (maximum capacities 100 t, 200 t, 300 t).....	11
4.1.3	Load cells PR 6201/520 t and DB (maximum capacity 520 t).....	12
4.2	General information.....	12
4.3	Dual bridge.....	13
4.4	Possible marking of the load cell for the Ex area.....	13
4.5	Dimensions.....	14
4.5.1	Load cells PR 6201/52...54 (maximum capacities 500 kg...50 t).....	14
4.5.2	Load cell PR 6201/15 (maximum capacity 100 t).....	15
4.5.3	Load cell PR 6201/25 (max. capacity 200 t), PR 6201/35 (max. capacity 300 t).....	16
4.5.4	Load cell PR 6201/520 t (maximum capacity 520 t).....	17
4.5.5	Load cell PR 6201/15 DB (maximum capacity 100 t).....	18
4.5.6	Load cell PR 6201/25 DB (max. capacity 200 t), PR 6201/35 DB (max. capacity 300 t).....	19
4.5.7	Load cell PR 6201/520 t DB (maximum capacity 520 t).....	20
4.6	Ordering information.....	21
4.6.1	Load cells PR 6201/52...54 (maximum capacities 500 kg...50 t).....	21
4.6.2	Load cell PR 6201/15...35, 520 t (maximum capacities 100...300 t, 520 t).....	21
4.6.3	Dual bridge load cells (maximum capacities 100...300 t, 520 t).....	22
4.7	Technical data.....	22

4.7.1	Load cells PR 6201/52...54 (maximum capacities 500 kg...50 t).....	22
4.7.2	Load cell PR 6201/15...35, 520 t (maximum capacities 100...300 t, 520 t).....	25
4.7.3	Dual bridge load cell (maximum capacities 100...300 t, 520 t).....	27
5	Installation.....	30
5.1	Safety instructions.....	30
5.2	Aligning the load cell.....	31
5.3	Installation of the upper load disc for max. capacity of 500 kg...50 t.....	32
6	Connection.....	33
6.1	General information.....	33
6.2	Load cell.....	34
6.2.1	Connecting single load cells type LA.....	35
6.2.2	Connecting two load cells type LA.....	35
6.2.3	Load cell cable.....	36
6.3	Cable connections.....	36
7	Preparing for calibration.....	39
7.1	General notes.....	39
7.2	Smart Calibration.....	39
7.3	Mechanical height adaptation.....	39
8	Troubleshooting.....	40
8.1	General Notes.....	40
8.2	Visual inspection.....	40
8.3	Metrological controls.....	40
8.3.1	Checking the zero output signal of the load cell.....	40
8.3.2	Checking the strain gauge bridge of the load cell.....	41
8.3.3	Checking the insulation impedance of the load cell.....	41
8.3.4	Checking the insulation impedance of the connecting cable.....	42
9	Maintenance/repairs/cleaning.....	43
9.1	Maintenance.....	43
9.2	Repairs.....	43
9.3	Cleaning.....	43
10	Disposal.....	44
11	Spare parts and accessories.....	45
11.1	Replacement parts.....	45
11.2	Accessories.....	45
11.2.1	Mounting kits.....	45
11.2.2	Load discs.....	47
11.2.3	Connecting cables.....	47
11.2.4	Cable junction boxes.....	47

12	Certificates/safety instructions/control drawing	49
12.1	BVS 16 ATEX E 005	50
12.2	IECEX BVS 16.0005	54
12.3	TÜV 03 ATEX 2301X	58
12.4	IECEX TUN 17.0025X	64
12.5	MIN16ATEX001X	68
12.6	FM17CA0138	70
12.7	FM17US0276	73
12.8	4012 101 5688	76
12.9	MEU17027	77
12.10	RU Д-DE.A301.B.05345	83
12.11	RU C-DE.MIO62.B.05836	84
12.12	DE.C.28.541.A No. 68244	87
12.13	DE-14-PC-PTB002	93
12.14	DE-14-PC-PTB003	100
12.15	R60/2000-DE1-14.01	106
12.16	NMI S333A	109

1 Introduction

1.1 Read the manual

- Please read this manual carefully and completely before using the product.
- This manual is part of the product. Keep it in a safe and easily accessible location.

1.2 This is what operating instructions look like

1. - n. are placed before steps that must be done in sequence.
 - ▶ is placed before a step.
 - ▷ describes the result of a step.

1.3 This is what lists look like

- indicates an item in a list.

1.4 This is what menu items and softkeys look like

[] frame menu items and softkeys.

Example:

[Start]- [Applications]- [Excel]

1.5 This is what the safety instructions look like

Signal words indicate the severity of the danger involved when measures for preventing hazards are not followed.

DANGER

Warning of personal injury

DANGER indicates death or severe, irreversible personal injury which will occur if the corresponding safety measures are not observed.

- ▶ Take the corresponding safety precautions.

WARNING

Warning of hazardous area and/or personal injury

WARNING indicates that death or severe, irreversible injury may occur if appropriate safety measures are not observed.

- ▶ Take the corresponding safety precautions.

CAUTION

Warning of personal injury.

CAUTION indicates that minor, reversible injury may occur if appropriate safety measures are not observed.

- ▶ Take the corresponding safety precautions.

NOTICE**Warning of damage to property and/or the environment.**

NOTICE indicates that damage to property and/or the environment may occur if appropriate safety measures are not observed.

- ▶ Take the corresponding safety precautions.

Note:

User tips, useful information, and notes.

1.6 Hotline

Phone: +49.40.67960.444

Fax: +49.40.67960.474

eMail: help@minebea-intec.com

2 Safety instructions

2.1 General notes

NOTICE

Warning of damage to property and/or the environment.

The product was in perfect condition with regard to safety features when it left the factory.

- ▶ To maintain this condition and to ensure safe operation, the user must follow the instructions and observe the warnings in this manual.

2.2 Intended use

The load cell PR 6201 has been designed especially for weighing silos, tanks, and process vessels.

The load cell PR 6201 may only be used as intended for weighing tasks.

In intrinsically safe circuits, only load cells PR 6201/..E may be used.

The dimensions of all mounting and structural components must be calculated so that sufficient overload capacity is ensured for all loads which may occur while taking the relevant standards into account. In particular, upright weighing objects must be safeguarded against the weighing installation turning over or being shifted, thus eliminating danger to people, animals, or goods even in the case of a break in a load cell or mounting element.

Installation and repair work must only be carried out by expert/qualified personnel.

The load cell reflects the state of the art. The manufacturer does not accept any liability for damage caused by third-party system components or due to incorrect use of the product.

2.3 Initial inspection

Check the contents of the consignment for completeness. Check the contents visually to determine whether any damage has occurred during transport. If there are grounds for rejection of the goods, a claim must be filed with the carrier immediately. The Minebea Intec sales or service organization must also be notified.

2.4 Before operational startup

NOTICE

Perform visual inspection.

- ▶ Before operational startup as well as after storage or transport, inspect the load cell visually for signs of mechanical damage.

3 Recommendations for installation

3.1 Load cell and constrainer arrangement

Examples:

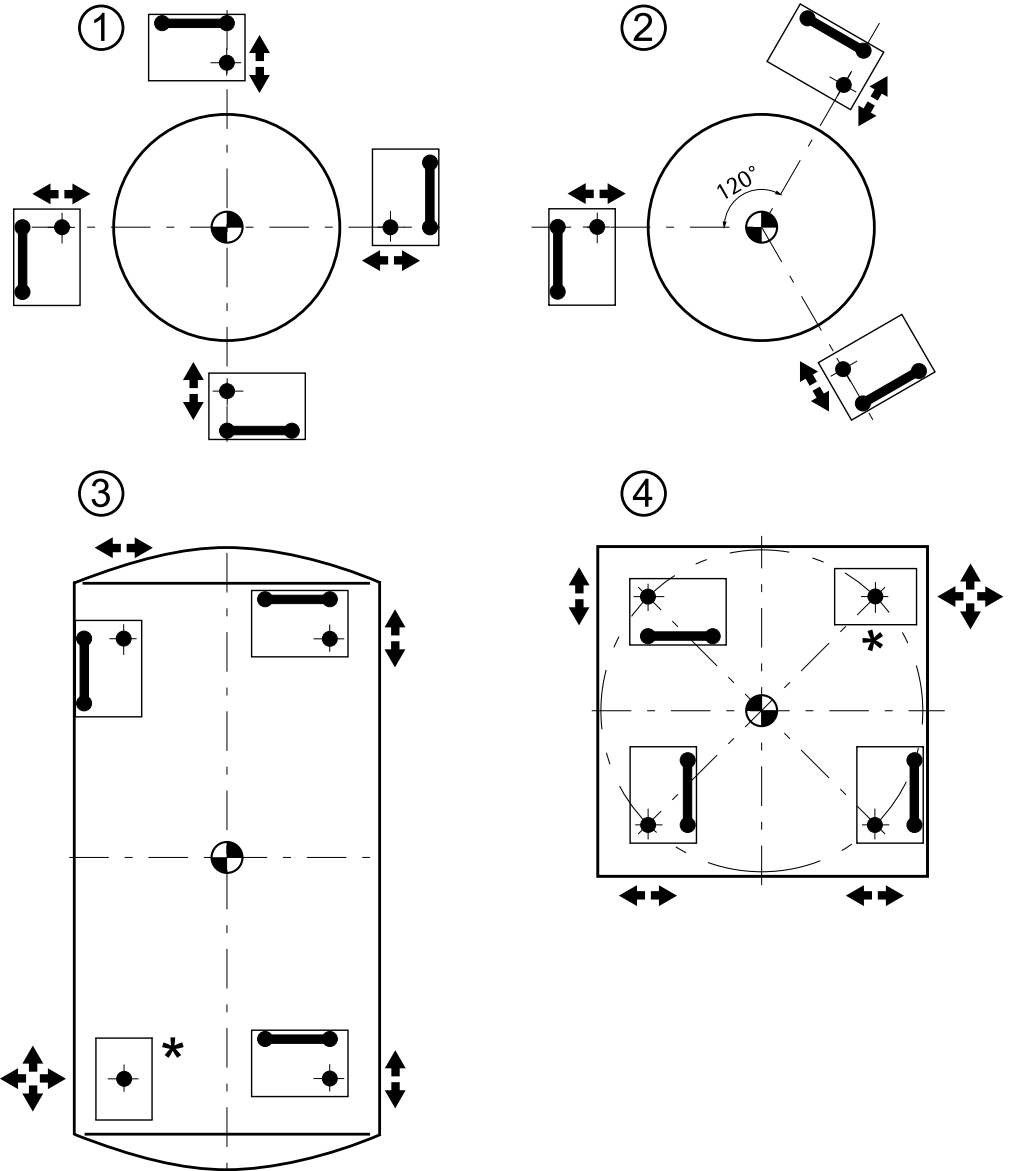

Key

*	Do not constrain this position.
	Constrainer
	Load application
	Possible direction of movement

- The supporting structure of the scale (i.e. the load cell support) and the vessel must be stable enough to withstand the specified loads, be horizontal (water level!) and flat.
- Vessels should preferably be supported by 3 load cells, platforms by 4 or 6 load cells (see figure).
- Transverse and/or horizontal forces and torques exceeding the permissible limits are disturbances which can generate measuring errors and, in the worst case, may damage the load cell.
- If the object to be measured is constrained properly, damage and measuring errors can be prevented without affecting the required space for movement in the direction of the measurement.

Consideration should be given to the fact that thermal expansion and contractions may constrict the required space for movement of the object to be weighed and could thereby lead to significant falsification of the measuring results.

Therefore, special attention should be paid to the design, arrangement, and condition of the constrainers.

3.2 Location of load cells and pivots

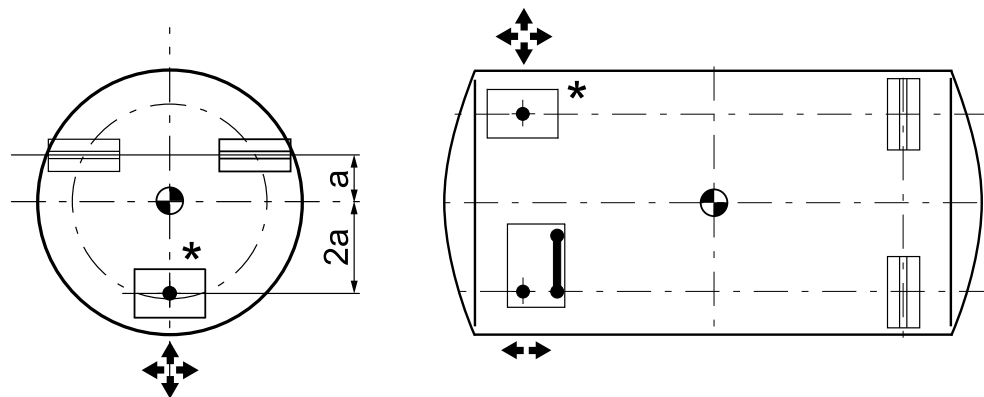

Key

	Pivot PR 6101
*	Do not constrain this position.
	Constrainer
	Load application
	Possible direction of movement

3.3 Additional lift-off protection

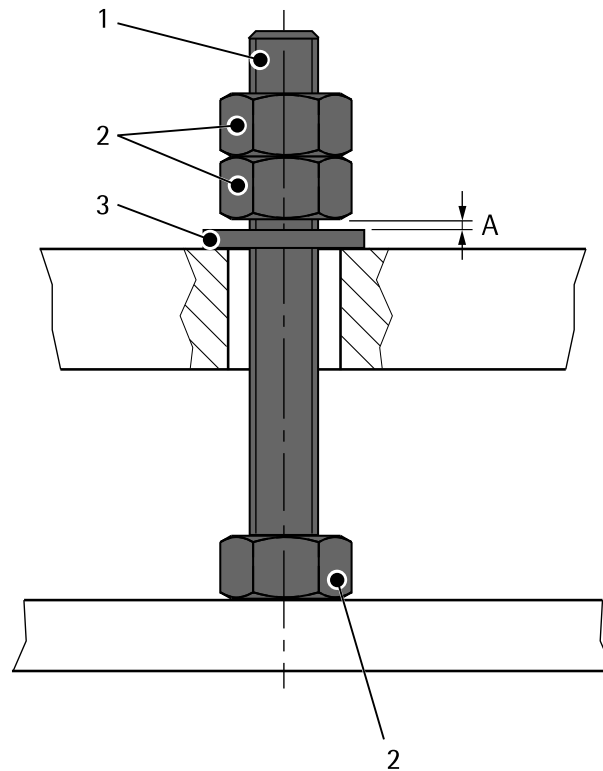

For safety reasons, a lift-off protection has to be generally provided on vessels. This can be constructed separately or additionally installed in the mounting kit (see Chapter [11.2.1](#)).

For this purpose, the simplest version requires the following components:

- 1× threaded bar (1)
- 3× nut (2)
- 1× washer (3)

Assembly:

- Mount the threaded bar (1) so that it has sufficient free moving space in the drill hole.
- Lock the nuts (2) so that there is a remaining distance A^* from the washer (3).

* $A = 2 \text{ mm}$

This distance is essential to avoid force shunts.

3.4 Selecting maximum capacity

The load cell PR 6201 has a high overload capacity due to the fact that the material stress is low ($500 \text{ kg} \dots 30 \text{ t} = 1 \text{ mV/V}$).

Forces exceeding the safe load limit E_{lim} in the measuring direction may change the characteristics of the load cell or damage it.

If the safe load limit E_{lim} of the load cell can be exceeded, e.g. by falling loads, then mechanical limiting in load direction is strongly recommended.

If the destructive load E_d of the load cell is exceeded, there is danger of mechanical destruction.

4 Specifications

4.1 Equipment supplied with the load cell

4.1.1 Load cells PR 6201/52...54 (max. capacity 500 kg...50 t)

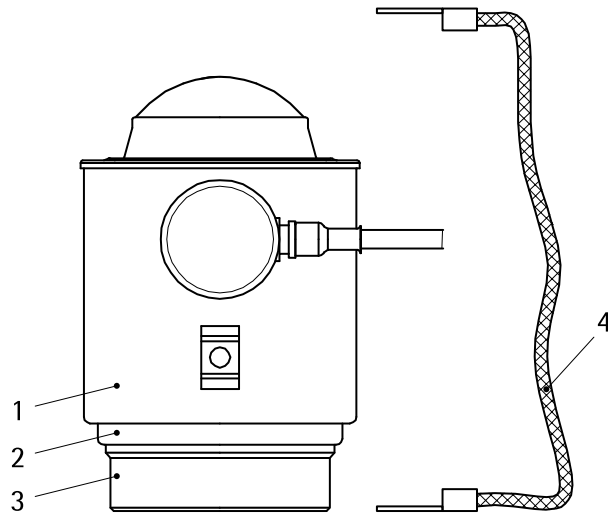

No.	Description
1	Load cell
2	Supporting ring
3	Lower load disc
4	Flexible copper strap
Positions not shown:	
5	Quick guide
6	Calibration Certificate
7	Only with Ex-load cells: Safety information for Ex-load cells

4.1.2 Load cells PR 6201/15, /25, /35 and DB (maximum capacities 100 t, 200 t, 300 t)

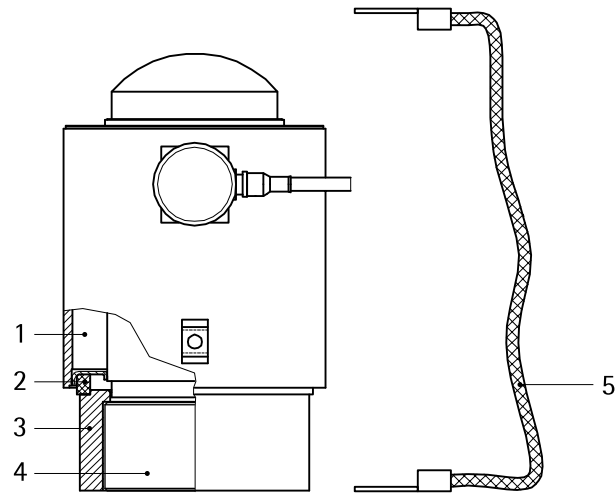

No.	Description
1	Load cell
2	Supporting ring
3	Ring for lower load disc
4	Lower load disc
5	Flexible copper strap
Positions not shown:	
6	Quick guide
7	Calibration Certificate
8	Only with Ex-load cells: Safety information for Ex-load cells

4.1.3 Load cells PR 6201/520 t and DB (maximum capacity 520 t)

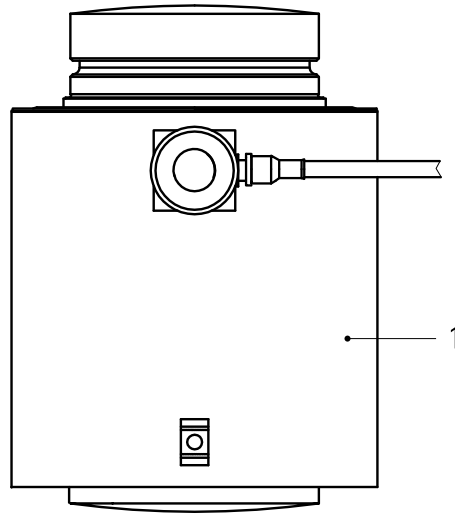

No.	Description
1	Load cell
Positions not shown:	
2	Quick guide
3	Calibration Certificate
4	Only with Ex-load cells: Safety information for Ex-load cells

Note:

The load disc set PR 6143/55 has to be ordered separately, see Chapter [11.2.1](#).

4.2 General information

Restoring force	For each mm of displacement that the top of the load cell is shifted from the vertical axis, a horizontal restoring force is generated: $E_{max} \leq 10 \text{ t}$: 0.65% of the load resting vertically on the load cell $E_{max} \geq 20 \text{ t}$: 1.55% of the load resting vertically on the load cell $E_{max} = 100 \text{ t}$: 1.23% of the load resting vertically on the load cell $E_{max} = 200 \text{ t} + 300 \text{ t}$: 0.65% of the load resting vertically on the load cell $E_{max} = 520 \text{ t}$: 1.20% of the load resting vertically on the load cell
Material for load cell housing	Stainless steel 1.4301 acc. to DIN EN 10088-3 (corresponds to AISI 304, B.S. 304S11/S15)
Protection against environmental influences	Hermetically sealed by welding. Filled with inert gas.

Protection classes	in compliance with IEC 529 or DIN EN 60529 IP66/IP68/IP69: Dust-proof and leak-tight against water, with harmful effects when immersed, (1.5 m water depth, 10,000 h) and water jets (high pressure and temperature). Explosion: Suitable for explosion subgroup IIC and IIIC.
Protection type	Intrinsic safety for PR 6201/..E + ..DBE
Ambient temperature in the Ex area	see additional information "safety instructions for Ex load cells" only with approval RU C-DE.MIO62.B.05836: -52...+55 °C
Cable diameter	5 mm
Cable length	$E_{\max} \leq 10$ t: 5 m $E_{\max} > 10$ t: 12 m
Cable gauge	4x0.35 mm ²
Cable bend radius	≥25 mm (fixed installation) ≥75 mm (flexible installation)
Cable sheath material	Thermoplastic elastomer (TPE)
Cable sheath color	Gray (standard version) Blue (Ex version) Green (LA version)

4.3 Dual bridge

The Dual Bridge load cell has two separate measuring circuits, which are independent of each other. The measuring circuits are adjusted in two separate adjustment chambers, for cable connections see Chapter 6.3.

4.4 Possible marking of the load cell for the Ex area

Zone	Marking	Certificate no.	for
0 and 1	II 1G Ex ia IIC T6 Ga Ex ia IIC T6 Ga 0Ex ia IIC T6	BVS 16 ATEX E 005 IECEX BVS 16.0005 RU C-DE.MIO62.B.05836*	only PR 6201/..E + ..DBE
20 and 21	II 1D Ex ta IIIC T160 °C Da Ex ta IIIC T160 °C Da Ex ta IIIC T160 °C X	TÜV 03 ATEX 2301X IECEX TUN 17.0025X RU C-DE.MIO62.B.05836*	PR 6201/..L, ..D1, ..C3-C6, ..N
2	II 3G Ex nA IIC T6 Gc 2Ex nA IIC T6 X	MIN16ATEX001X RU C-DE.MIO62.B.05836*	PR 6201/..L, ..D1, ..C3-C6, ..N, ..LDB, ..NDB
22	II 3D Ex tc IIIC T85 °C Dc Ex tc IIIC T85 °C X	MIN16ATEX001X RU C-DE.MIO62.B.05836*	PR 6201/..L, ..D1, ..C3-C6, ..N, ..LDB, ..NDB

* Certification body: Prommash Test LLC
(Accrediting code MIO62)

Zone	Marking	Certificate no.	for
	IS CL I, II, III, DIV 1, GP A, B, C, D, E, F, G Enti- ty - 4012 101 5688 NI CL I, II, III, DIV 2, GP A, B, C, D, E, F, G - 4012 101 5688; NIFW T4A Ta= -40°C to 70°C; T5 Ta= -40°C to 55°C	FM17US0276	PR 6201/..L, ..D1, ..C3-C6, ..N
	IS CL I, II, III, DIV 1, GP A, B, C, D, E, F, G Enti- ty - 4012 101 5688 NI CL I, II, III, DIV 2, GP A, B, C, D, E, F, G - 4012 101 5688; NIFW T4A Ta= -40°C to 70°C; T5 Ta= -40°C to 55°C	FM17CA0138	PR 6201/..L, ..D1, ..C3-C6, ..N

NOTICE

Installation in the Ex area

- For installations in the Ex area, it is imperative to observe the Ex safety instructions in the installation manuals.

4.5 Dimensions

4.5.1 Load cells PR 6201/52...54 (maximum capacities 500 kg...50 t)

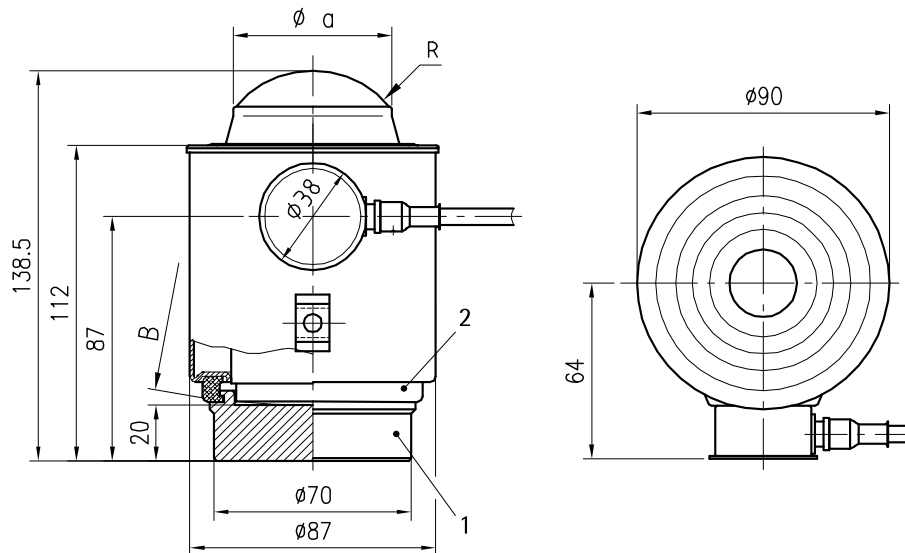

all dimensions in mm

No.	Description
1	Lower load disc
2	Supporting ring

Model	ϕa [mm]	R [mm]	B [mm]
PR 6201/52...23	24	15	150
PR 6201/33...14	34	15	150
PR 6201/24...54	56	35	220

4.5.2 Load cell PR 6201/15 (maximum capacity 100 t)

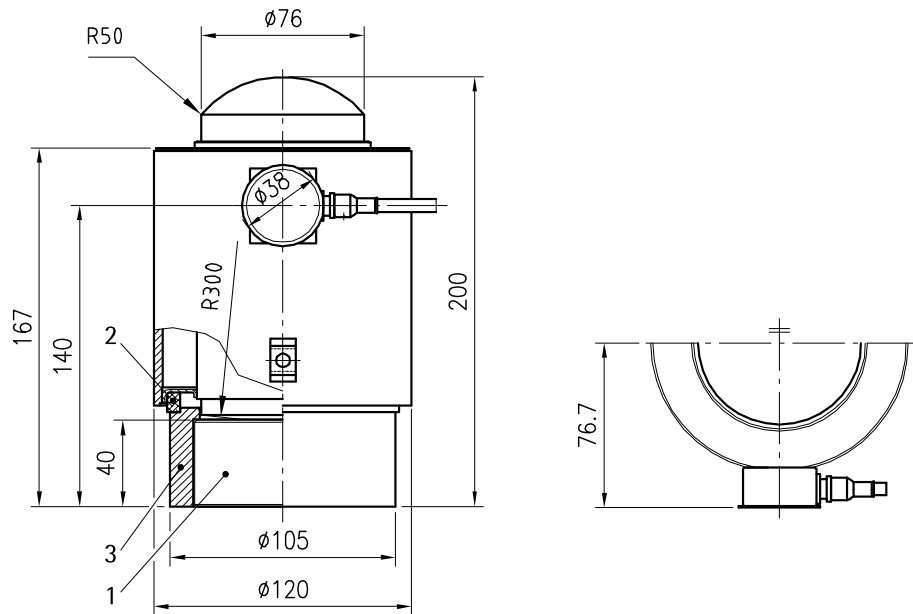

all dimensions in mm

No.	Description
1	Lower load disc
2	Supporting ring
3	Ring for lower load disc

4.5.3 Load cell PR 6201/25 (max. capacity 200 t), PR 6201/35 (max. capacity 300 t)

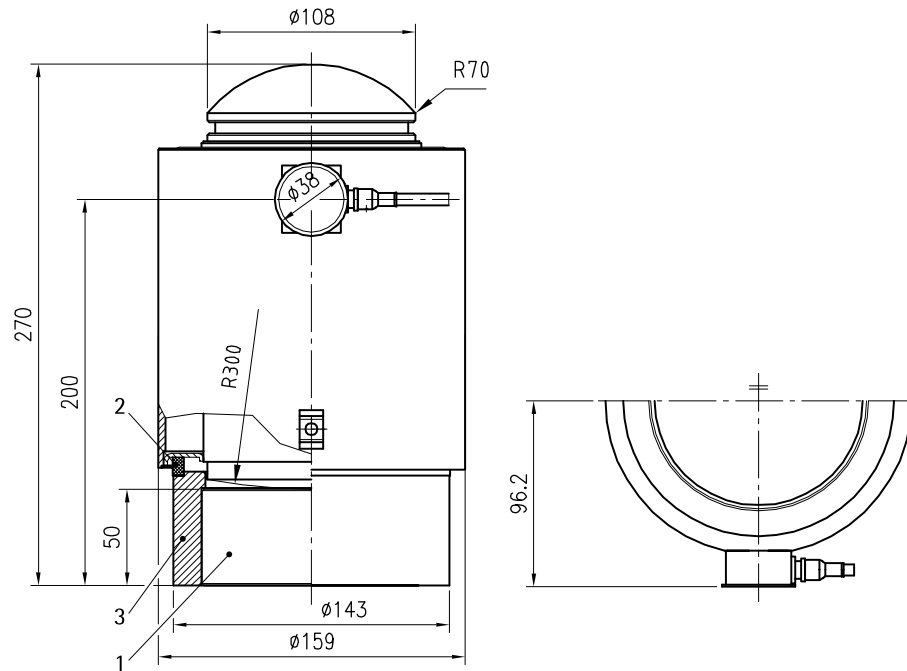

all dimensions in mm

No.	Description
1	Lower load disc
2	Supporting ring
3	Ring for lower load disc

4.5.4 Load cell PR 6201/520 t (maximum capacity 520 t)

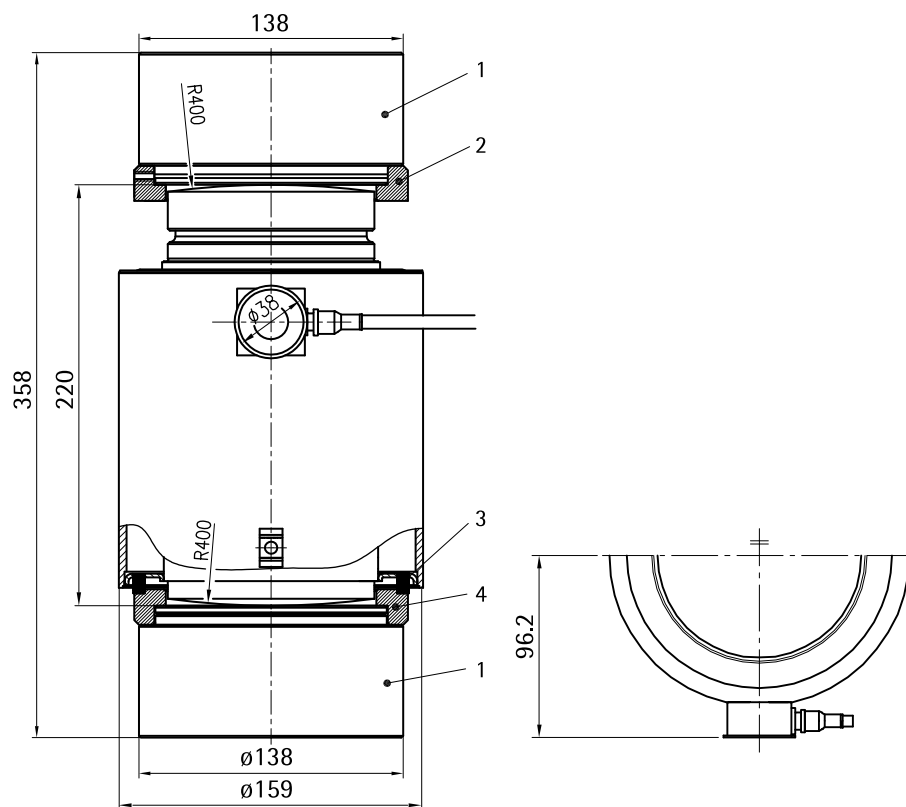

all dimensions in mm

No.	Description
1	Upper/lower load disc
2	Ring for upper load disc
3	Supporting ring
4	Ring for lower load disc

Note:

The scope of delivery does **not** include these parts!

Load disc set PR 6143/55, see Chapter [11.2.1](#).

4.5.5 Load cell PR 6201/15 DB (maximum capacity 100 t)

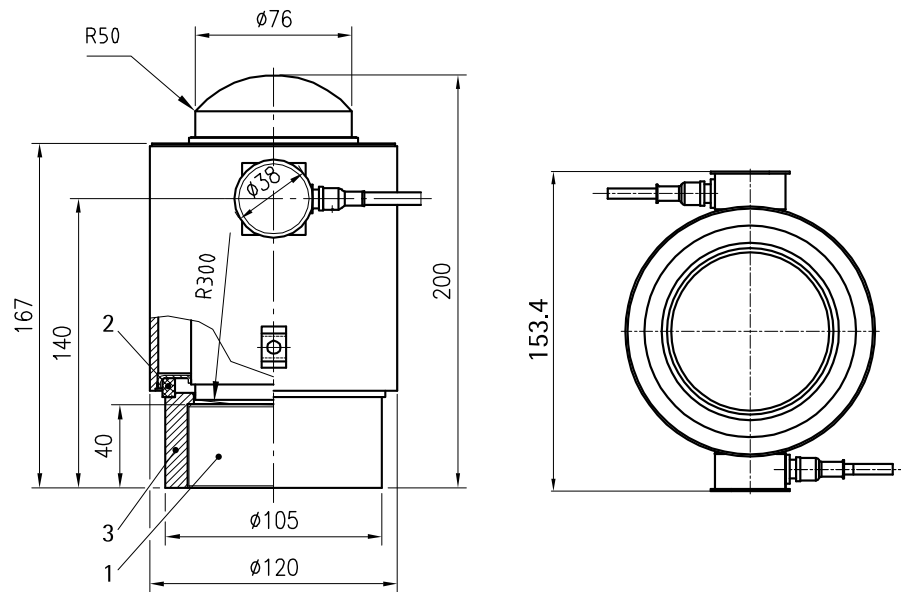

all dimensions in mm

No.	Description
1	Lower load disc
2	Supporting ring
3	Ring for lower load disc

4.5.6 Load cell PR 6201/25 DB (max. capacity 200 t), PR 6201/35 DB (max. capacity 300 t)

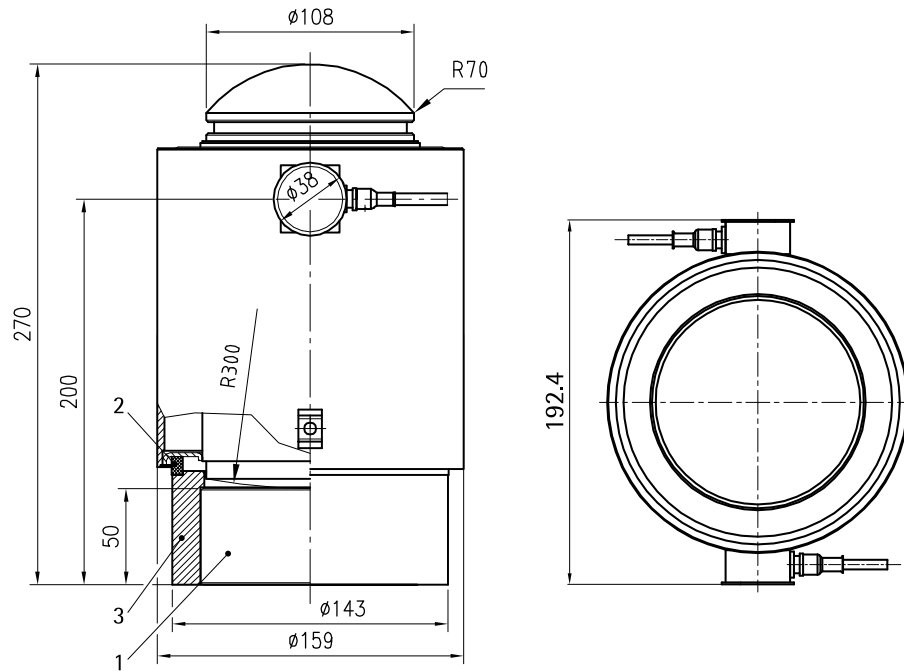

all dimensions in mm

No.	Description
1	Lower load disc
2	Supporting ring
3	Ring for lower load disc

4.5.7 Load cell PR 6201/520 t DB (maximum capacity 520 t)

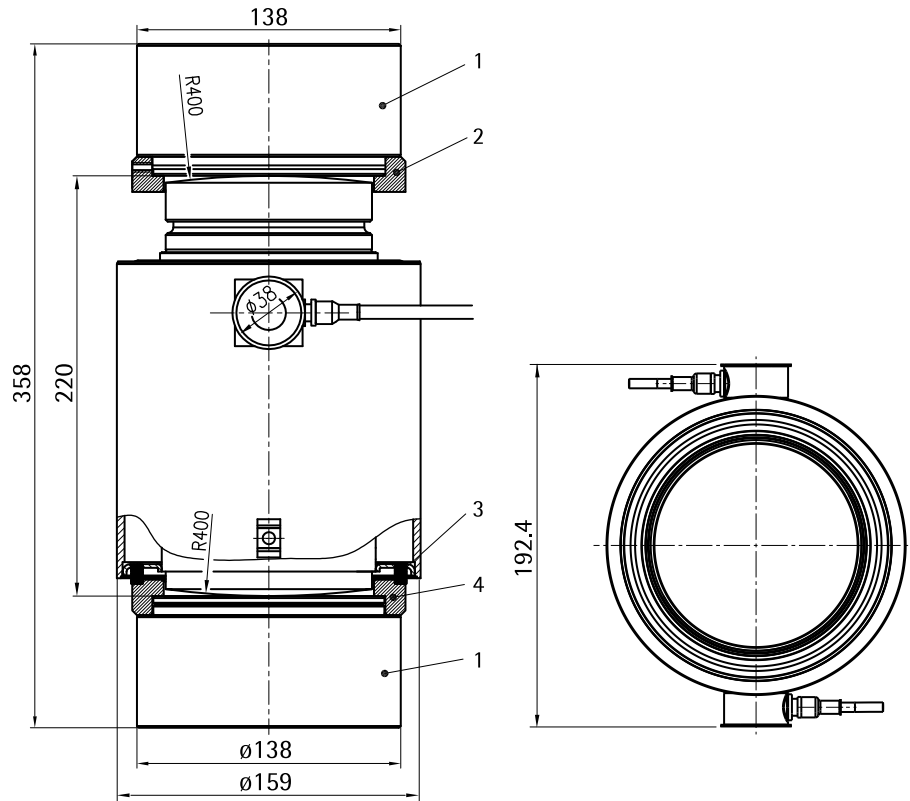

all dimensions in mm

No.	Description
1	Upper/lower load disc
2	Ring for upper load disc
3	Supporting ring
4	Ring for lower load disc

Note:

The scope of delivery does **not** include these parts!

Load disc set PR 6143/55, see Chapter [11.2.1](#).

4.6 Ordering information

4.6.1 Load cells PR 6201/52...54 (maximum capacities 500 kg...50 t)

Model	Max. capacity E_{max}	Type
PR 6201/52	500 kg	..LA
PR 6201/13	1 t	..LA
PR 6201/23	2 t	..LA/C3/C3E
PR 6201/33	3 t	..LA/C3/C3E
PR 6201/53	5 t	..LA/C3/C3E
PR 6201/14	10 t	..LA/C3/C3E
PR 6201/24	20 t	..LA/C3/C3E/C4/C4E/C5/C5E/C6/C6E
PR 6201/34	30 t	..LA/C3/C3E/C4/C4E/C5/C5E/C6/C6E
PR 6201/54	50 t	..LA/C3/C3E/C4/C4E/C5/C5E/C6/C6E

Legend

Type	Accuracy class
LA =	internal with amplifier
Cx =	According to OIML R60
CxE =	Ex version according to OIML R60

x = scale interval code

Note:

Error class of the individual types, see Chapter [4.7](#).

4.6.2 Load cell PR 6201/15...35, 520 t (maximum capacities 100...300 t, 520 t)

Model	Max. capacity E_{max}	Type
PR 6201/15	100 t	..L/LA/N/NE
PR 6201/25	200 t	..L/N/NE
PR 6201/35	300 t	..N/NE
PR 6201/520 t	520 t	..L/LE

Legend

Type	Accuracy class
L =	Internal
LA =	internal with amplifier

Type		Accuracy class
N	=	Internal
LE	=	Ex version internal
NE	=	Ex version internal

Note:

Error class of the individual types, see Chapter [4.7](#).

4.6.3 Dual bridge load cells (maximum capacities 100...300 t, 520 t)

Model	Max. capacity E_{max}	Type
PR 6201/15 DB	100 t	..NDB/NDBE
PR 6201/25 DB	200 t	..NDB/NDBE
PR 6201/35 DB	300 t	..NDB/NDBE
PR 6201/520 t DB	520 t	..LDB/LDBE

Legend

Type		Accuracy class
LDB	=	Internal
NDB	=	Internal
LDBE	=	Ex version internal
NDBE	=	Ex version internal

Note:

Error class of the individual types, see Chapter [4.7](#).

4.7 Technical data

4.7.1 Load cells PR 6201/52...54 (maximum capacities 500 kg...50 t)

Designation	Description	Abbr.	LA	C3, C3E	C4, C4E	C5, C5E	C6, C6E	Unit
Accuracy class			0.25	0.015	0.012	0.010	0.008	% E_{max}
Minimum dead load	lowest limit of specified measuring range	E_{min}	0	0	0	0	0	% E_{max}
Maximum capacity	highest limit of specified measuring range	E_{max}	See Chapter 4.6					

Designation	Description	Abbr.	LA	C3, C3E	C4, C4E	C5, C5E	C6, C6E	Unit
Safe load limit	maximum load without irreversible damage	E _{lim}	120	200	200	200	200	% E _{max}
	for E _{max} = 50 t	E _{lim}	120	150	150	150	...	% E _{max}
Destructive load	danger of mechanical destruction	E _d	>500	>500	>500	>500	>500	% E _{max}
	for E _{max} = 50 t	E _d	>300	>300	>300	>300	...	% E _{max}
Minimum LC verification	minimum load cell scale interval, v _{min} = E _{max} /Y	Y	...	14000	20000	20000	20000	
	for E _{max} = 3 t	Y	...	9000	
	for E _{max} = 2 t	Y	...	7000	
	for E _{max} = 1 t	Y	
	for E _{max} = 0.5 t	Y	
Minimum pre-load signal recurrence	recurrence of the minimum preload signal (DR = 1/2 × E _{max} /Z)	Z	...	3000	8000	8000	8000	
	for E _{max} = 50 t	Z	...	3000	6000	6000	...	
Rated output	Relative output signal at maximum capacity (LA = 4...20 mA)	C _n	16 mA	1	1	1	1	mV/V
	for E _{max} = 50 t	C _n	16 mA	2	2	2	...	mV/V
Tolerance on rated output	permissible deviation from rated output C _n	d _c	<1.0	<0.07	<0.07	<0.07	<0.07	% C _n
Zero output signal	load cell output signal under unloaded condition * Tolerance on zero signal: -2 ± 2% C _n , i.e. 3.36 mA...4.00 mA	S _{min}	4 mA*	0 ± 1.0	0 ± 1.0	0 ± 1.0	0 ± 1.0	% C _n
Repeatability	max. change in load cell output for repeated loading	ε _R	<0.02	0.005	0.005	0.005	0.005	% C _n
Creep	max. change of output signal at E _{max} during 30 minutes	d _{cr}	<0.05	<0.015	<0.0125	<0.010	<0.008	% C _n
Non-linearity ¹⁾	deviation from best straight line through zero	d _{Lin}	<0.25	<0.01	<0.01	<0.01	<0.01	% C _n

Designation	Description	Abbr.	LA	C3, C3E	C4, C4E	C5, C5E	C6, C6E	Unit
Hysteresis ¹⁾	max. difference in LC output between loading and unloading	d _{hy}	<0.25	<0.015	<0.0125	<0.010	<0.008	% C _n
Temperature effect on S _{min}	max. change of S _{min} in B _T	TK _{Smin}	<0.15	<0.01	<0.007	<0.007	<0.007	% C _n /10 K
Temperature effect on C ¹⁾	max. change of C in B _T	TK _C	<0.1	<0.01	<0.008	<0.007	<0.005	% C _n /10 K
Input impedance	between supply terminals	R _{LC}	...	650 ±6				Ω
Output impedance	between measuring terminals	R _O	...	610 ±0.5				Ω
	for E _{max} = 50 t	R _O	460 ±0.5	...	Ω
Insulation impedance	between measuring circuit and housing, U _{DC} = 100 V	R _{IS}	...	>5000				MΩ
Insulation voltage	between circuit and housing (Ex versions only)		...	500	500	500	500	V
Recommended supply voltage	to hold the specified performance	B _U	20...28	4...24	4...24	4...24	4...24	V
Max. supply voltage	permissible for continuous operation without damage	U _{max}	28	32	32	32	32	V
	Ex versions:	U _{max}	...	25	25	25	25	V
Nominal ambient temp. range	to hold the specified performance	B _T						°C
Usable ambient temp. range	permissible for continuous operation without damage	B _{Tu}	-30...+55	-40...+95				°C
Storage temperature range	without electrical and mechanical stress	B _{Ti}	-40...+70	-40...+95				°C
Permissible eccentricity	permissible displacement from nominal load line at the head of the load cell E _{max} ≤10 t	S _{ex}			10			mm
	E _{max} >10 t	S _{ex}			5			mm

Designation	Description	Abbr.	LA	C3, C3E	C4, C4E	C5, C5E	C6, C6E	Unit
Vibration resistance	resistance against oscillations (IEC 60068-2-6-Fc)		20 g, 100 h, 10...150 Hz					
Barometric pressure influence	influence of barometric pressure on output < to $E_{max} = 2$ t	PK _{Smin}	280	280	280	280	280	g/kPa
	$E_{max} = 3...10$ t	PK _{Smin}	320	320	320	320	320	g/kPa
	> $E_{max} = 20$ t	PK _{Smin}	420	420	420	420	420	g/kPa
Nominal deflection	elastic deformation under maximum capacity < to $E_{max} = 30$ t	S _{nom}	<0.5	<0.5	<0.5	<0.5	<0.5	mm
	for $E_{max} = 50$ t	S _{nom}	<0.8	<0.8	<0.8	<0.8	...	mm

1) The data for non-linearity (d_{Lin}), hysteresis (d_{hy}) and and temperature effect on C (TK_C) are typical values.

For OIML R60 or NTEP approved load cells the sum of these values is within the permissible cumulative error limits.

Definitions acc. to OIML R60

The technical data given are intended solely as a product description and should not be interpreted as guaranteed properties in the legal sense.

4.7.2 Load cell PR 6201/15...35, 520 t (maximum capacities 100...300 t, 520 t)

Designation	Description	Abbr.	L	LA	L, LE 520 t	N, NE	Unit
Accuracy class			0.5	0.5	0.5	0.06	% E_{max}
Minimum dead load	lowest limit of specified measuring range	E_{min}	0	0	0	0	% E_{max}
Maximum capacity	highest limit of specified measuring range	E_{max}	See Chapter 4.6				
Safe load limit	maximum load without irreversible damage for $E_{max} = 100$ t	E_{lim}	200	120	...	200	% E_{max}
	for $E_{max} = 200$ t	E_{lim}	...	120	...	200	% E_{max}
	for $E_{max} = 300$ t	E_{lim}	133	% E_{max}
	for $E_{max} = 520$ t	E_{lim}	106	...	% E_{max}

Designation	Description	Abbr.	L	LA	L, LE 520 t	N, NE	Unit
Destructive load	danger of mechanical destruction for $E_{max} = 100$ t	E_d	>500	>500	...	>500	% E_{max}
	for $E_{max} = 200$ t	E_d	...	>500	...	>500	% E_{max}
	for $E_{max} = 300$ t	E_d	>333	% E_{max}
	for $E_{max} = 520$ t	E_d	192	...	% E_{max}
Rated output	relative output at maximum capacity	C_n	1.0	16 mA	2.6	1	mV/V
	for $E_{max} = 300$ t	C_n	1.5	mV/V
Tolerance on rated output	permissible deviation from rated output C_n	d_c	<1.0	<1.0	<1.0	<0.25	% C_n
Zero output signal	load cell output signal under unloaded condition	S_{min}	0 ± 2.0	4 mA	0 ± 2.0	0 ± 1.0	% C_n
Repeatability	max. change in load cell output for repeated loading	ϵ_R	<0.02	<0.02	<0.02	0.01	% C_n
Creep	max. change of output signal at E_{max} during 30 minutes	d_{cr}	<0.05	<0.05	<0.2	<0.03	% C_n
Non-linearity ¹⁾	deviation from best straight line through zero	d_{Lin}	<0.3	<0.3	<0.1	<0.05	% C_n
Hysteresis ¹⁾	max. difference in LC output between loading and unloading	d_{hy}	<0.25	<0.25	<0.5	<0.06	% C_n
	for $E_{max} = 100$ t	d_{hy}	<0.25	<0.25	...	<0.04	% C_n
	for $E_{max} = 300$ t	d_{hy}	<0.1	% C_n
Temperature effect on S_{min}	max. change of S_{min} in B_T	$TK_{S_{min}}$	<0.2	<0.2	<0.2	<0.06	% $C_n/10$ K
Temperature effect on $C^1)$	max. change of C in B_T	TK_C	<0.1	<0.1	<0.1	<0.03	% $C_n/10$ K
Input impedance	between supply terminals	R_{LC}	650 +50..		650 \pm 50	650 \pm 6	Ω
Output impedance	between measuring terminals	R_O	610 \pm 3	...	610 \pm 3	610 \pm 1	Ω
Insulation impedance	between measuring circuit and housing, $U_{DC} = 100$ V	R_{IS}	>5000	...	>5000	>5000	M Ω
Insulation voltage	between circuit and housing (Ex versions only)		500	...	500	500	V
Recommended supply voltage	to hold the specified performance	B_u	4...24	20...28	4...24	4...24	V
Max. supply voltage	permissible for continuous operation without damage	U_{max}	32	28	32	32	V
	Ex versions:	U_{max}	25	25	V

Designation	Description	Abbr.	L	LA	L, LE 520 t	N, NE	Unit
Nominal ambient temp. range	to hold the specified performance	B _T	-10...+55				°C
Usable ambient temp. range	permissible for continuous operation without damage	B _{Tu}	-40... +95	-30... +55	-40... +95	-40... +95	°C
Storage temperature range	without electrical and mechanical stress	B _{Ti}	-40... +95	-40... +70	-40... +95	-40... +95	°C
Permissible eccentricity	permissible displacement from nominal load line at the head of the load cell	S _{ex}			10		mm
Vibration resistance	resistance against oscillations (IEC 60068-2-6-Fc)			20 g, 100 h, 10...150 Hz			
Barometric pressure influence	influence of barometric pressure on output	PK _{Smin} ...		1400	1400	1400	g/kPa
	for E _{max} = 100 t	PK _{Smin} 700	700	700	...	700	g/kPa
Nominal deflection	elastic deformation under maximum capacity	S _{nom}	2.7	...	mm
	for E _{max} = 100 t	S _{nom} 1.0	1.0	1.0	...	1.0	mm
	for E _{max} = 200 t	S _{nom}	1.6	...	1.6	mm
	for E _{max} = 300 t	S _{nom}	2.4	mm

1) The data for non-linearity (d_{Lin}), hysteresis (d_{hy}) and temperature effect on C (TKC) are typical values.
For OIML R60 or NTEP approved load cells the sum of these values is within the permissible cumulative error limits.

Definitions acc. to OIML R60

The technical data given are intended solely as a product description and should not be interpreted as guaranteed properties in the legal sense.

4.7.3 Dual bridge load cell (maximum capacities 100...300 t, 520 t)

Designation	Description	Abbr.	LDB, LDBE	NDB, NDBE	Unit
Accuracy class			0.5	0.06	% E _{max}
Minimum dead load	lowest limit of specified measuring range	E _{min}	0	0	% E _{max}
Maximum capacity	highest limit of specified measuring range	E _{max}	See Chapter 4.6		
Safe load limit	maximum load without irreversible damage for E _{max} = 100 t	E _{lim}	...	200	% E _{max}

Designation	Description	Abbr.	LDB, LDBE	NDB, NDBE	Unit
	for $E_{\max} = 200$ t	E_{lim}	...	200	% E_{\max}
	for $E_{\max} = 300$ t	E_{lim}	...	133	% E_{\max}
	for $E_{\max} = 520$ t	E_{lim}	106	...	% E_{\max}
Destructive load	danger of mechanical destruction for $E_{\max} = 100$ t	E_d	...	>500	% E_{\max}
	for $E_{\max} = 200$ t	E_d	...	>500	% E_{\max}
	for $E_{\max} = 300$ t	E_d	...	>333	% E_{\max}
	for $E_{\max} = 520$ t	E_d	192	...	% E_{\max}
Rated output	relative output at maximum capacity	C_n	2.6	1	mV/V
	for $E_{\max} = 300$ t	C_n	...	1.5	mV/V
Tolerance on rated output	permissible deviation from rated output C_n	d_c	<1.0	<0.25	% C_n
Zero output signal	load cell output signal under unloaded condition	S_{min}	0 ± 2.0	0 ± 1.0	% C_n
Repeatability	max. change in load cell output for repeated loading	ε_R	<0.02	0.01	% C_n
Creep	max. change of output signal at E_{\max} during 30 minutes	d_{cr}	<0.2	<0.03	% C_n
Non-linearity ¹⁾	deviation from best straight line through zero	d_{Lin}	<0.1	<0.05	% C_n
Hysteresis ¹⁾	max. difference in LC output between loading and unloading	d_{hy}	<0.5	<0.06	% C_n
	for $E_{\max} = 100$ t	d_{hy}	...	<0.04	% C_n
	for $E_{\max} = 300$ t	d_{hy}	...	<0.1	% C_n
Temperature effect on S_{min}	max. change of S_{min} in B_T	$TK_{S_{\text{min}}}$	<0.2	<0.06	% $C_n/10$ K
Temperature effect on $C^1)$	max. change of C in B_T	TK_C	<0.1	<0.03	% $C_n/10$ K
Input impedance	between supply terminals	R_{LC}	650 ± 50	650 ± 6	Ω
Output impedance	between measuring terminals	R_O	610 ± 3	610 ± 1	Ω
Insulation impedance	between measuring circuit and housing, $U_{\text{DC}} = 100$ V	R_{IS}	>5000	>5000	$M\Omega$
Insulation voltage	between circuit and housing (Ex versions only)		500	500	V
Recommended supply voltage	to hold the specified performance	B_u	4...24	4...24	V

Designation	Description	Abbr.	LDB, LDBE	NDB, NDBE	Unit
Max. supply voltage	permissible for continuous operation without damage	U_{max}	32	32	V
	Ex versions:	U_{max}	25	25	V
Nominal ambient temp. range	to hold the specified performance	B_T	-10...+55	-10...+55	°C
Usable ambient temp. range	permissible for continuous operation without damage	B_{Tu}	-40...+95	-40...+95	°C
Storage temperature range	without electrical and mechanical stress	B_{Ti}	-40...+95	-40...+95	°C
Permissible eccentricity	permissible displacement from nominal load line at the head of the load cell	S_{ex}	10	10	mm
Vibration resistance	resistance against oscillations (IEC 60068-2-6-Fc)		20 g, 100 h, 10...150 Hz	20 g, 100 h, 10...150 Hz	
Barometric pressure influence	influence of barometric pressure on output	PK_{Smin}	1400	1400	g/kPa
	for $E_{max} = 100$ t	PK_{Smin}	...	700	g/kPa
Nominal deflection	elastic deformation under maximum capacity for $E_{max} = 100$ t	S_{nom}	...	1.0	mm
	for $E_{max} = 200$ t	S_{nom}	...	1.6	mm
	for $E_{max} = 300$ t	S_{nom}	...	2.4	mm
	for $E_{max} = 520$ t	S_{nom}	2.7	...	mm

1) The data for non-linearity (d_{Lin}), hysteresis (d_{hy}) and temperature effect on C (TKC) are typical values.
For OIML R60 or NTEP approved load cells the sum of these values is within the permissible cumulative error limits.

Definitions acc. to OIML R60

The technical data given are intended solely as a product description and should not be interpreted as guaranteed properties in the legal sense.

5 Installation

5.1 Safety instructions

NOTICE

Welding or lightning strike current flowing through the cell can damage it.

All electrical welding on the weighing system must be finished before mounting the load cells.

- ▶ When installing the load cell, immediately bypass the load cell with the flexible copper strap provided for this purpose (included in the equipment supplied, see Chapter 4.1).

During any additional electrical welding work near the load cell:

- Disconnect the load cell cables.
- Bypass the load cell using the flexible copper strap.
- Make sure that the grounding clamp of the welding set is fitted as closely as possible to the welding joint.

The following must be observed during installation:

- Do not lift or transport the load cell by pulling on the cable.
- Avoid shock stress (falling down, hard shocks).
- The load cell must be installed vertically and centrally in the mounting kit.
- Load forces must act in the measuring direction of the load cell.
- The load disc must not be subjected to transverse forces.
- All contact points between load cell and load disc must be adequately greased.
Load cell grease order no., see Chapter 11.1.

NOTICE

Changes of temperature >15 K/h may influence the measuring accuracy.

- ▶ Make sure to protect the load cells from direct heating or cooling effects (sun, wind, heat radiation, fan heaters), e.g., heat protection screens or heat protection housings are to be installed if necessary.

NOTICE

Force shunts may cause measuring errors.

- ▶ All incoming and outgoing lines (hoses, pipes, cables) must be coupled to the measured object as flexibly as possible.

5.2 Aligning the load cell

Load cells must be installed so that their axis is vertical when not in use.

Even minor deviations can lead to unexpected effects.

When the PR 6001/.. mounting kit is used, the correct position of the adjustment notches ensures that it is positioned properly (vertical and not jammed or wedged).

If the load cell is installed on a slant accidentally, then this changes its characteristic value.

Under no circumstances can this be compensated for electrically (e.g. by resistances in the junction box). Instead, all load cells have to be carefully aligned: Refer to figure.

To make it easier to get an exact vertical alignment, the PR 6001/.. mounting kit is equipped with a mounting aid.

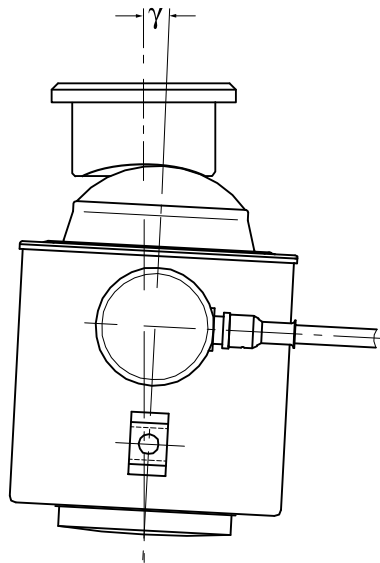

$$\gamma \leq 1^\circ$$

The maximum permissible inclination must be strictly observed so that measuring accuracy is not adversely overly affected (see figure).

Note:

The material properties and the shape of the load cells and load discs are perfectly matched to one another. Always use load discs from Minebea Intec, see also Chapter [11.2.2](#).

Procedure:

- Lift up weighing object approx. 5 mm using a jack-up or corresponding lifting device.
 - Correct the position of the load cell using the supporting ring on the lower load disc.
 - Set the weighing object back down on the mounting kit and make sure that the load cell is vertical and the load cell dome is positioned in the exact center of the load disc.
 - Check to ensure that the adjustment notches are in the correct position.
-

Note:

Further installation instructions can be found in the manuals of the respective mounting kits.

5.3 Installation of the upper load disc for max. capacity of 500 kg...50 t

Note:

The figures below shows a schematic of load cell and upper load disc.

Small load cell radius (15 mm)

$E_{\max} = 500 \text{ kg} \dots 10 \text{ t}$

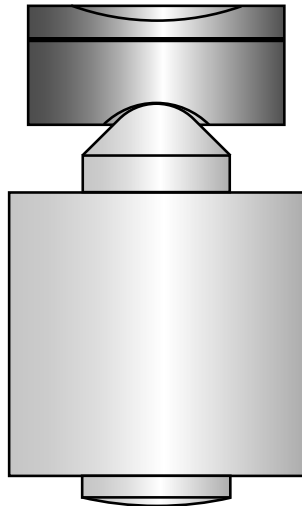

Large load cell radius (35 mm)

$E_{\max} = 20 \dots 50 \text{ t}$

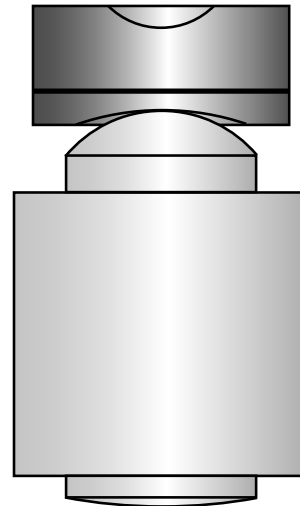
**Note:**

Load discs made of stainless steel are marked with a double groove.

Further installation instructions can be found in the manuals of the respective mounting kits.

6 Connection

6.1 General information

- Protect the cable ends against contamination. Moisture must not get into the open end of the cable.
- Do not shorten the load cell connecting cable. Connect the prepared cable end and roll up the remaining cable.
- The screen of the load cell cable and the screen of the connecting cable must not be connected inside the cable junction box if connection of both ends is not permissible according to the regulations for installation in the explosion-prone area.
- Keep the load cell cables away from power cables.
- The distance between measurement cables and power cables and/or components under high voltage should be at least 1 m (reference value).
- We recommend laying the load cell cables in separate cable trays or armored steel pipes.
- Power cables should be crossed at right angles while taking into account the minimum distance of 1 m (reference value).

Note:

If hum interference occurs, the cable screens should only be connected on one side.

Depending on the design of the cable junction box used, either the jumper J3 must be removed or the cable screens must be disconnected from the terminal contacts highlighted in yellow.

⚠ WARNING**When installing in potentially explosive atmospheres:**

It is imperative that you follow the application-dependent installation instructions!

- ▶ Always check whether it is permissible to bilaterally connect the screens to the equipotential bonding.
-

6.2 Load cell

Color Code

rd	=	red
gn	=	green
bu	=	blue
gy	=	gray

Type L, D1/N, D1E/NE, Cx, CxE

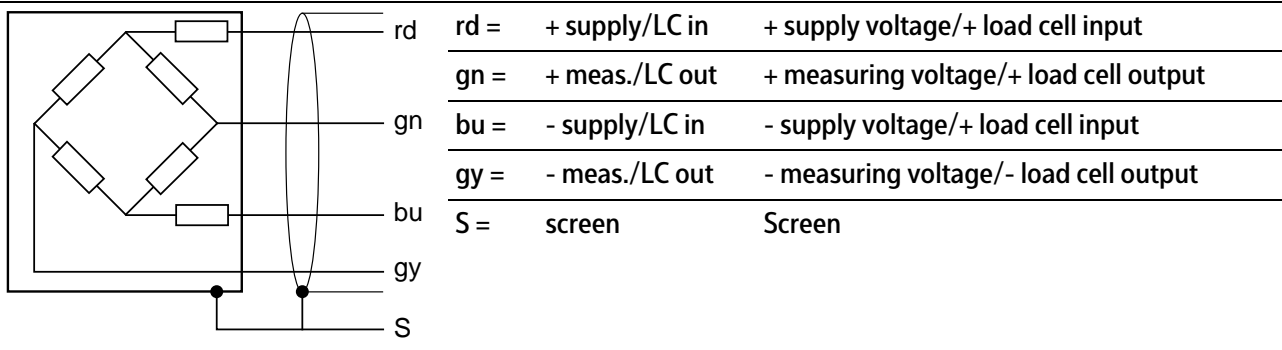

With integrated amplifier (type LA)

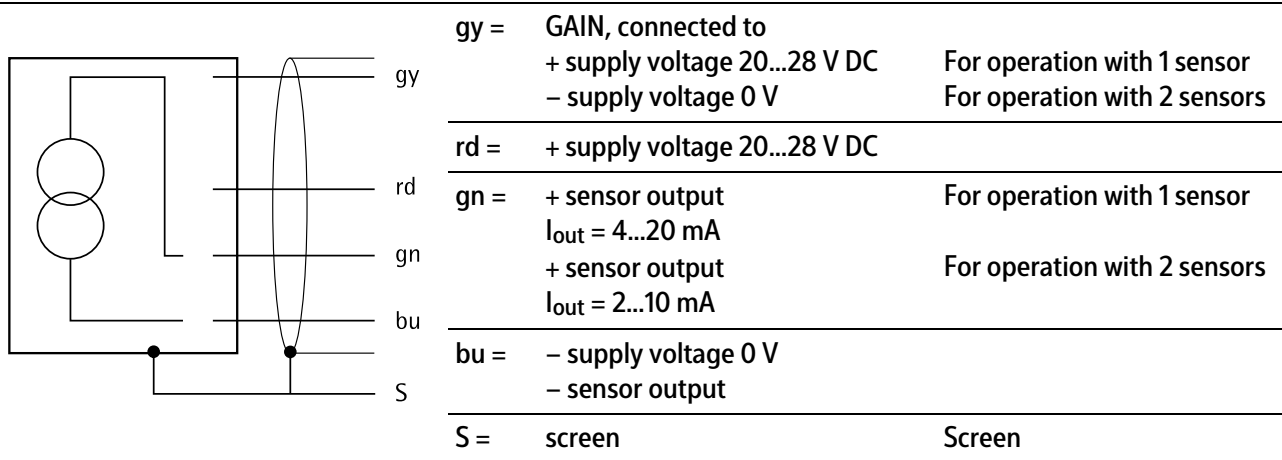

Note:

The maximum cable length between the load cell and the electronic instrumentation is 500m.

6.2.1 Connecting single load cells type LA

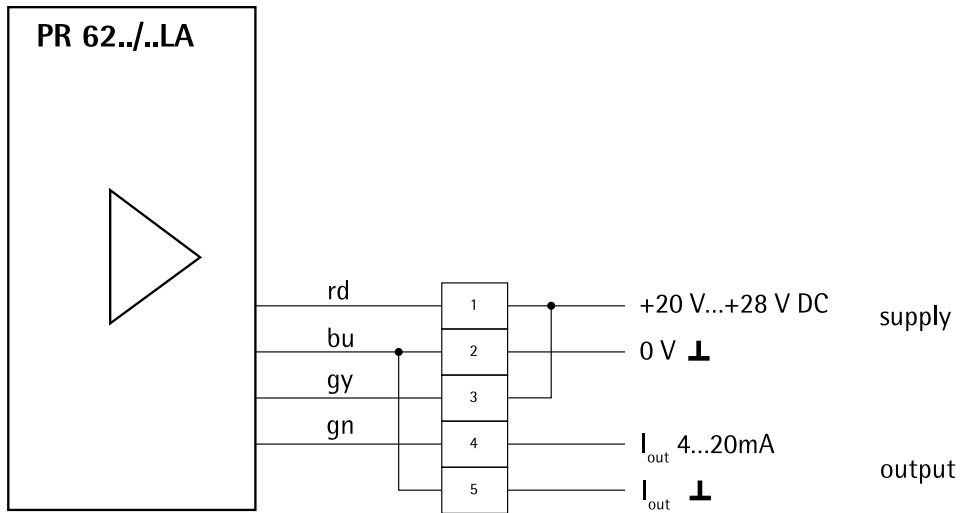

6.2.2 Connecting two load cells type LA

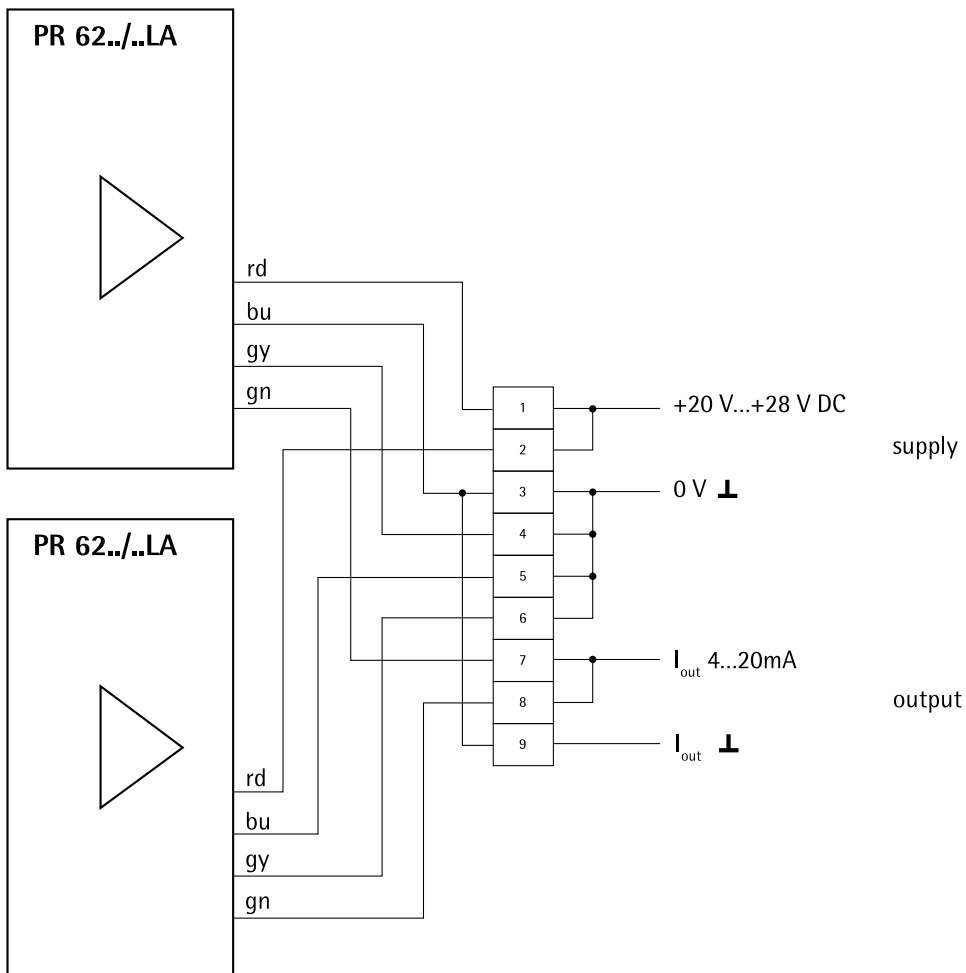

6.2.3 Load cell cable

The load cell cables are inseparably connected to the load cells in the factory and their individual resistance and temperature effect are equalized with the load cells.

Therefore, never shorten the cables, rather simply roll up the extra length and secure it.

The special sheathing material and the integrated strain relief with Kevlar thread ensure extremely long service life even under difficult operating conditions.

However, despite the robust nature of the materials used, the cable should be protected from excessive chemical and mechanical stresses. Preventing water from penetrating the end of the cable is also important "life insurance" for the system.

6.3 Cable connections

Note:

All components are only shown schematically.

Color code

bk	=	black
----	---	-------

bu	=	blue
----	---	------

gn	=	green
----	---	-------

gy	=	gray
----	---	------

rd	=	red
----	---	-----

wh	=	white
----	---	-------

Note:

Not for type LA load cells.

Connection example: Load cells with a measuring circuit

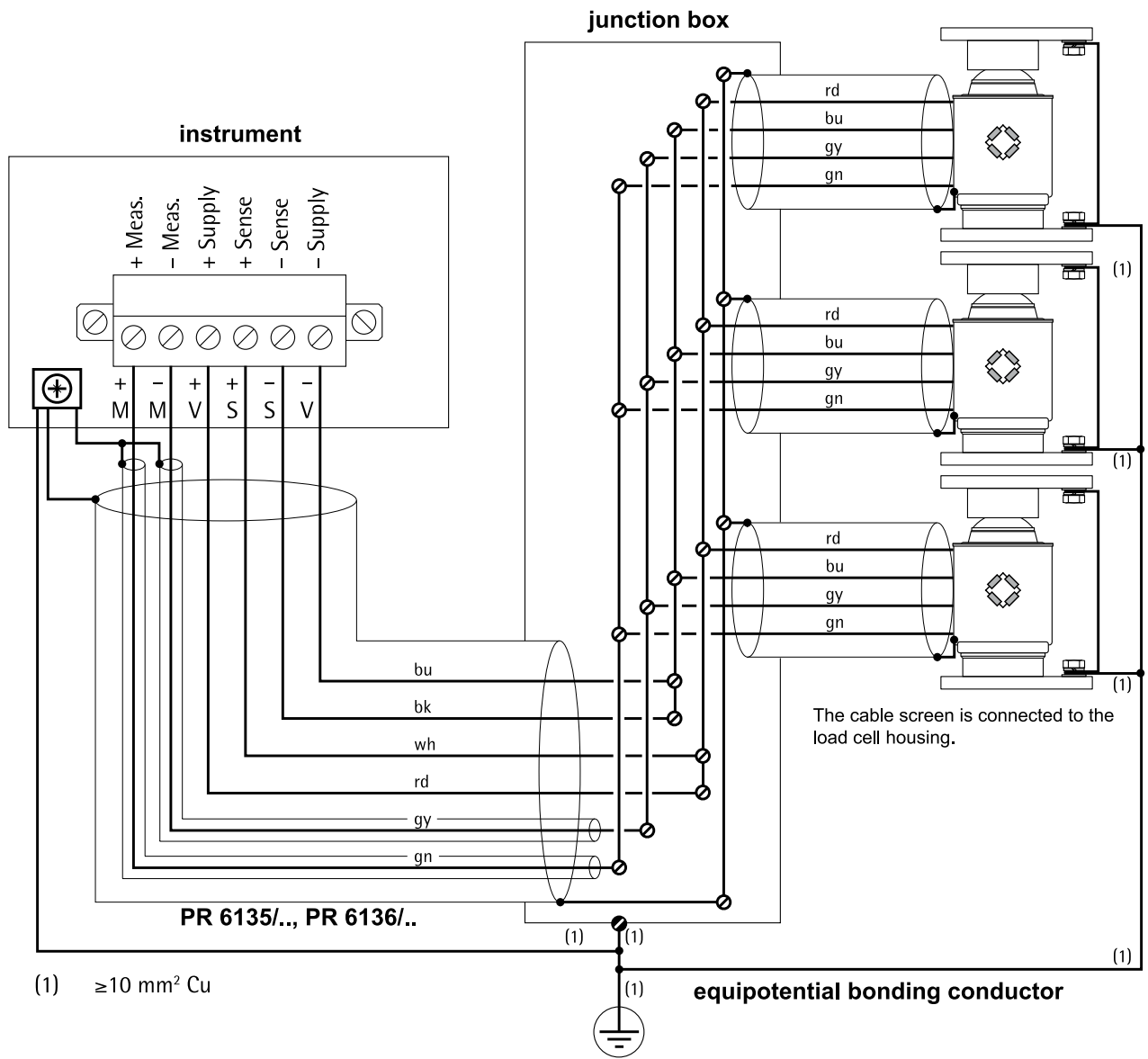

(1) $\geq 10 \text{ mm}^2 \text{ Cu}$

equipotential bonding conductor

Connection example: Load cells with two separate measuring circuits

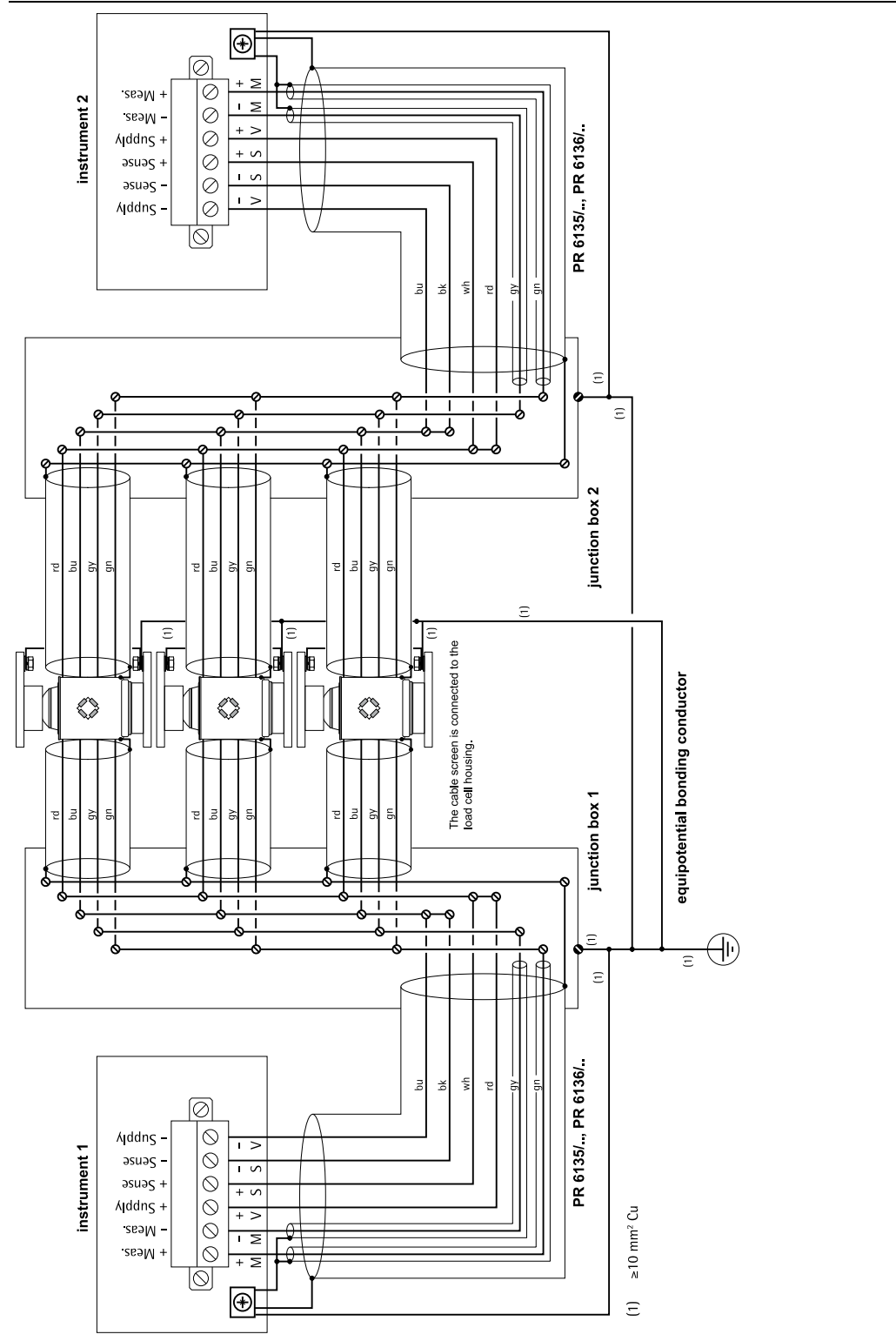

7 Preparing for calibration

7.1 General notes

Note:

For calibration of the measuring system, please refer to the manual of the corresponding indicator.

7.2 Smart Calibration

When using Minebea Intec devices, we recommend always running "Smart Calibration" first.

This allows all required values to be extracted from the Calibration Certificate supplied.

- The "Hysteresis correction values for Smart Calibration" listed on the Calibration Certificate are entered for [Correction A] and [Correction B] under [Hysteresis error] - [specified] in the indicator.

If the values are not available on the Calibration Certificate, [Hysteresis error] - [not specified] must be selected.

- The value listed under "Output at max. capacity" on the Calibration Certificate is entered in the indicator under [LC output at max. capacity].
- The value listed under "Output impedance" on the Calibration Certificate is entered in the indicator under [LC output impedance].

By performing these steps, a logical and highly accurate reading (typically better than 0.1%) is generated before the scale is even loaded for the first time.

7.3 Mechanical height adaptation

To distribute the load over the load cells as evenly as possible, height adaptation is required in systems with more than 3 load cells prior to calibration.

Procedure:

1. Place the dead load (e.g. empty vessel) onto the load cells of the scale structure.
2. Energize the load cells in parallel with a stabilized voltage (e.g.: $U_{DC} = 12\text{ V}$).
3. Measure the output voltages of each individual load cell by means of a digital voltmeter and compare the individual values.
 - ▷ Given deviation between the output voltages of the load cells, the load on the load cell with the lowest output voltage must be increased by putting shims between mounting plate and weighing construction.
4. Lift the weighing object immediately beside the affected load cell.
5. Place thin, deburred sheets of metal (0.5–2 mm thick) between the upper mounting plate and the scale structure.
6. Measure the output voltages of the load cells again and adjust the height of this load cell or of another one.

8 Troubleshooting

8.1 General Notes

The following hints will enable a technician to do an initial diagnostic or help in case of incorrect or non-reproducible weighing results after commissioning and calibration.

8.2 Visual inspection

Component	Possible errors
Weighing object	Are all pipes, hoses and cables free from shunt forces? Are the connections pliable and connected horizontally? Are elements with a solid connection to the scale in direct contact with the surroundings? Has friction developed between the weighing object and its surroundings (e.g. dusty openings, ...)?
Cable junction box	Has moisture intruded? Do all soldering and screw connections have secure contact?
Connecting cables	Is the sheath damaged? Has moisture intruded?
Mounting kit	Is the lift-off protection in contact with the scale? Are the constrainers stuck?
Load cell	Is the load cell vertical? Is the adjustment chamber cover damaged? Is the sheath of the load cell cable damaged? Has moisture penetrated into the load cell cable?

8.3 Metrological controls

8.3.1 Checking the zero output signal of the load cell

- Unload load cell.
- Disconnect the load cell measuring outputs.
- Check whether the output voltage without load is within the limits.

Type	Output voltage
L	0 mV \pm 0.02 mV/V
D1/N/C3	0 mV \pm 0.01 mV/V
for PR 6201/54..	0 mV \pm 0.02 mV/V
LA	3.2... 4 mA GAIN connected to +supply voltage 24 \pm 4 V, see Chapter 6.2.1 .

8.3.2 Checking the strain gauge bridge of the load cell

Note:

Not for type LA load cells.

- Do not exceed the test voltage.
- Check whether the values of the resistors are within the permissible limits.

Max. test voltage

- Standard version $U_{DC} = 32\text{ V}$
- Intrinsically safe version (PR ../..E) $U_{DC} = 25\text{ V}$

Type	Input impedance (red core, blue core)	Output impedance (green core, gray core)
L	$650\ \Omega +50\ \Omega$	$610\ \Omega \pm 3\ \Omega$
D1/N	$650\ \Omega \pm 6\ \Omega$	$610\ \Omega \pm 1\ \Omega$
C3-C6	$650\ \Omega \pm 6\ \Omega$	$610\ \Omega \pm 0.5\ \Omega$

8.3.3 Checking the insulation impedance of the load cell

NOTICE

Possible destruction of load cell

- ▶ Never apply test voltage between two cores of the load cell cable.
 - ▶ Insulate the load cell cores.
-

Note:

Not for type LA load cells.

Max. test voltage

- Standard version $U_{DC} = 100\text{ V}$
- Intrinsically safe version (PR ../..E) $U_{AC} = 500\text{ V}$

Insulation impedance	Core – housing	$>5000\text{ M}\Omega$
	Core – screen	$>5000\text{ M}\Omega$
	Screen – housing	$<0.2\ \Omega$

8.3.4 Checking the insulation impedance of the connecting cable

- Disconnect connecting cable from measuring instrument and load cells.
- Insulate the cores of the connecting cable.

Insulation impedance	Core – core	$>120 \text{ M}\Omega \times \text{km}$
	Core – screen	$>120 \text{ M}\Omega \times \text{km}$

9 Maintenance/repairs/cleaning

9.1 Maintenance

The load cell PR 6201 is maintenance-free.

Load cell grease must be applied to the contact surfaces between the load cell and load discs. Load cell grease order number, see Chapter [11.1](#).

The load cell can be extensively sprayed with off-shore all-weather protection spray in aggressive environments.

Load cell grease specification

- good water/media resistance
- good corrosion protection properties
- good oxidization and aging stability
- good temperature resistance
- and, where appropriate, good compatibility with foodstuffs

The requirements referred to apply when taking into account the specific operating/usage conditions.

The grease also serves as protection against wear (low friction).

9.2 Repairs

The load cell PR 6201 is designed to be as robust as possible for the required measuring accuracy and is highly reliable.

Should an electrical or mechanical defect nevertheless occur, the load cell must be replaced.

Load cell repair is not possible.

9.3 Cleaning

Dirt on the load cell and movable parts of the scale must be cleaned as quickly as possible

- if it influences weighing, or
- if it is corrosive to the cell or cable material.

NOTICE

Some cleaning agents may not be compatible with the load cell material.

- ▶ When using cleaning agents, ensure that their compatibility with the load cell material has been tested and approved (see Chapter [4.2](#)).

10 Disposal

If the packaging is no longer required, please take it to your local waste disposal facility and/or a reputable disposal company or collection point. The packaging largely consists of environmentally friendly materials which can be used as secondary raw materials.

It is not permitted—even for small businesses—to dispose of this product with the regular household waste or at collection points run by local public waste disposal companies.

EU legislation requires its Member States to collect electrical and electronic equipment and dispose of it separately from other unsorted municipal waste so that it can then be recycled.

Before disposing of or scrapping the product, any batteries should be removed and taken to a suitable collection point.

Please see our T&Cs for further information.

Service addresses for repairs are listed in the product information supplied with the product and on our website (www.minebea-intec.com).

We reserve the right not to accept products that are contaminated with hazardous substances (ABC contamination) for repair.

Should you have any further questions, please contact your local service representative or our service center.

Minebea Intec GmbH

Repair center

Meiendorfer Strasse 205 A

22145 Hamburg, Germany

Phone: +49.40.67960.666

service.HH@minebea-intec.com

11 Spare parts and accessories

11.1 Replacement parts

No.	Description	Max. capacity	Order no.
1	Flexible copper strap, 400 mm long		5312 321 28057
2	Lower load disc with supporting ring	500 kg...10 t	5322 693 91416
3	Lower load disc with supporting ring	20 t, 30 t, 50 t	5312 693 98148
4	Supporting ring, default	500 kg...50 t	5322 532 70298
5	Supporting ring, food-safe	500 kg...50 t	5322 532 70317
6	Load cell grease 4x 5 g		5312 390 12001
7	Load disc set (bottom)	100 t	5312 693 98143
8	Upper load disc	100 t	5322 520 10552
9	Load disc set (bottom)	200 t, 300 t	5312 693 98144
10	Upper load disc	200 t, 300 t	5322 520 10553

11.2 Accessories

11.2.1 Mounting kits

To install the load cell, the following mounting kits / pivots are recommended:

No.	Description	Max. capacity	Order no.
1	Mounting kit PR 6001/00N	500 kg–10 t	9405 360 01001
2	Mounting kit PR 6001/00S	500 kg–10 t	9405 360 01002
3	Mounting kit PR 6001/01N	20–50 t	9405 360 01011
4	Mounting kit PR 6001/01S	20–50 t	9405 360 01012
5	Mounting kit PR 6001/02N	100 t	9405 360 01021
6	Mounting kit PR 6001/03N	200 t, 300 t	9405 360 01031
7	Mounting kit PR 6145/00N incl. lower load disc with supporting ring PR 6143/54S @ 20–50 t	500 kg–10 t	9405 361 45001
8	Mounting kit PR 6145/00S incl. lower load disc with supporting ring PR 6143/54S @ 20–50 t	500 kg–10 t	9405 361 45002
9	Mounting kit PR 6145/08N	100 t	9405 361 45081
10	Mounting kit PR 6145/10S	200 t, 300 t	9405 361 45101
11	Pivot PR 6101/53N	5 t	9405 561 01531
12	Pivot PR 6101/53S	5 t	9405 561 01532
13	Pivot PR 6101/24N	20 t	9405 561 01241
14	Pivot PR 6101/24S	20 t	9405 561 01242
15	Pivot PR 6101/54N	50 t	9405 561 01541

No.	Description	Max. capacity	Order no.
16	Pivot PR 6101/54S	50 t	9405 561 01542
17	Pivot PR 6101/15N	100 t	9405 561 01151
18	Pivot PR 6101/25N	200 t	9405 561 01251

N = steel zinc plated, passivated and sealed (RoHS-compliant)

S = stainless steel

No.	Description	Perm. horizontal force	Order no.
19	Maxi FLEXLOCK PR 6001/10N	≤25 kN	9405 360 01101
20	Maxi FLEXLOCK PR 6001/10S	≤25 kN	9405 360 01102
21	Maxi FLEXLOCK PR 6001/11N	≤25 kN	9405 360 01111
22	Maxi FLEXLOCK PR 6001/11S	≤25 kN	9405 360 01112
23	Maxi FLEXLOCK PR 6001/20N	≤50 kN	9405 360 01201
24	Maxi FLEXLOCK PR 6001/20S	≤50 kN	9405 360 01202
25	Maxi FLEXLOCK PR 6001/21N	≤50 kN	9405 360 01211
26	Maxi FLEXLOCK PR 6001/21S	≤50 kN	9405 360 01212
27	High capacity mounting kit PR 6001/30N	≤200 kN	9405 360 01301
28	High capacity mounting kit PR 6001/31N	≤200 kN	9405 360 01311
29	High capacity mounting kit PR 6001/32N	≤200 kN	9405 360 01321
30	High capacity mounting kit PR 6001/33N	≤200 kN	9405 360 01331
31	Mini FLEXLOCK PR 6143/00N	≤25 kN	9405 361 43001
32	Mini FLEXLOCK PR 6143/00S	≤25 kN	9405 361 43002
33	Mini FLEXLOCK PR 6143/10N	≤50 kN	9405 361 43101
34	Mini FLEXLOCK PR 6143/10S	≤50 kN	9405 361 43102
35	Mini FLEXLOCK PR 6143/15N	≤200 kN	9405 361 43151
36	Mini FLEXLOCK PR 6143/25N	≤200 kN	9405 361 43251
37	SeismicMount PR 6144/54N	≤370 kN	9405 361 44541
38	SeismicMount PR 6144/15N	≤440 kN	9405 361 44151
39	SeismicMount PR 6144/35N	≤520 kN	9405 361 44351
40	SeismicMount PR 6144/55N	≤520 kN	9405 361 44551
41	Constrainer PR 6143/80	≤2 kN	9405 361 43801
42	Constrainer PR 6143/83	≤20 kN	9405 361 43831
43	Horizontal constrainer PR 6152/02	≤200 kN	9405 361 52021

N = steel zinc plated, passivated and sealed (RoHS-compliant)

S = stainless steel

11.2.2 Load discs

To install the load cell, the following load discs are recommended:

No.	Description	Max. capacity	Order no.
1	Upper load disc, standard PR 6143/50N	500 kg–75 t	9405 361 43501
2	Upper load disc, PR 6143/50S	500 kg–75 t	9405 361 43502
3	Lower load disc with supporting ring PR 6143/24S	500 kg–10 t	9405 361 43242
4	Lower load disc with supporting ring PR 6143/54S	20–75 t	9405 361 43542
5	Load disc kit PR 6143/55N	520 t	9405 361 43551

N = steel zinc plated, passivated and sealed (RoHS-compliant)

S = stainless steel

11.2.3 Connecting cables

To connect the junction box to the weighing electronics, we recommend using the following connecting cables:

No.	Description	Order no.
1	PR 6135/xx	9405 361 35xx2
2	PR 6135/01A (armored)	9405 361 35019
3	PR 6136/xx (for installation inside the explosion-hazarded area)	9405 361 36xx1
4	PR 6136/01A (armored, for installation inside the explosion-hazarded area)	9405 361 36019

11.2.4 Cable junction boxes

We recommend using the following junction boxes:

No.	Description	Order no.
1	PR 6130/04 (aluminum, 1–4 load cells, IP67; not for PR 6201/..LA, ..LE, ..LDBE, ..NE, ..NDBE, ..D1E, ..CxE)	9405 361 30044
2	PR 6130/08 (polycarbonate, 1–8 load cells, IP65; not for PR 6201/..LA, ..LE, ..LDBE, ..NE, ..NDBE, ..D1E, ..CxE)	9405 361 30084
3	PR 6130/34Sa (1.4301, 1–4 load cells, IP68, IP69, verifiable; not for PR 6201/..LA, ..LE, ..LDBE, ..NE, ..NDBE, ..D1E, ..CxE)	9405 361 30344
4	PR 6130/35S (1.4301, 1–4 load cells, IP68, IP69, verifiable; not for PR 6201/..LA, ..LE, ..LDBE, ..NE, ..NDBE, ..D1E, ..CxE)	9405 361 30354
5	PR 6130/38S (1.4404, 1–8 load cells, IP68, IP69, verifiable; not for PR 6201/..LA, ..LE, ..LDBE, ..NE, ..NDBE, ..D1E, ..CxE)	9405 361 30384
6	PR 6130/64Sa (1.4301, 1–4 load cells, IP68, IP69, verifiable, ATEX, IECEx, FM; not for PR 6201/..LA)	9405 361 30644
7	PR 6130/65S (1.4301, 1–4 load cells, IP68, IP69, verifiable, ATEX, IECEx, FM; not for PR 6201/..LA)	9405 361 30654

No.	Description	Order no.
8	PR 6130/68S (1.4404, 1–8 load cells, IP68, IP69, verifiable, ATEX, IECEx, FM; not for PR 6201/..LA)	9405 361 30684

12 Certificates/safety instructions/control drawing

Ser. no.	Description	Document no.	see Chapter
1	EC-Type Examination Certificate	BVS 16 ATEX E 005	12.1
2	Certificate of Conformity	IECEX BVS 16.0005	12.2
3	EU-Type Examination Certificate	TÜV 03 ATEX 2301X	12.3
4	Certificate of Conformity	IECEX TUN 17.0025X	12.4
5	Manufacturer's Certificate	MIN16ATEX001X	12.5
6	Certificate of Conformity FM	FM17CA0138 FM17US0276	12.6 12.7
7	Control drawing FM	4012 101 5688	12.8
8	EU-Declaration of Conformity	MEU17027	12.9
9	Certificate of Conformity TR CU 020	RU Д-DE.A301.B.05345	12.10
10	Certificate of Conformity TR CU 012	RU C-DE.MЮ62.B.05836	12.11
11	MPA	DE.C.28.541.A No. 68244	12.12
12	Parts Certificate	DE-14-PC-PTB002	12.13
13	Parts Certificate	DE-14-PC-PTB003	12.14
14	OIML Certificate of Conformity (PTB)	R60/2000-DE1-14.01	12.15
15	Supplementary Certificate of Approval	NMI S333A	12.16

12.1 BVS 16 ATEX E 005



(1) **EG-Baumusterprüfbescheinigung**

(2) Geräte und Schutzsysteme zur bestimmungsgemäßen Verwendung in explosionsgefährdeten Bereichen - Richtlinie 94/9/EG

(3) Nr. der EG-Baumusterprüfbescheinigung: **BVS 16 ATEX E 005**

(4) Gerät: **Wägezelle Typ PR62**/**E**

(5) Hersteller: **Sartorius Mechatronics T&H GmbH**

(6) Anschrift: **Meiendorfer Straße 205, 22145 Hamburg**

(7) Die Bauart dieses Gerätes sowie die verschiedenen zulässigen Ausführungen sind in der Anlage zu dieser Baumusterprüfbescheinigung festgelegt.

(8) Die Zertifizierungsstelle der DEKRA EXAM GmbH, benannte Stelle Nr. 0158 gemäß Artikel 9 der Richtlinie 94/9/EG des Europäischen Parlaments und des Rates vom 23. März 1994, bescheinigt, dass das Gerät die grundlegenden Sicherheits- und Gesundheitsanforderungen für die Konzeption und den Bau von Geräten und Schutzsystemen zur bestimmungsgemäßen Verwendung in explosionsgefährdeten Bereichen gemäß Anhang II der Richtlinie erfüllt. Die Ergebnisse der Prüfung sind in dem Prüfprotokoll BVS PP 16.2012 EG niedergelegt.

(9) Die grundlegenden Sicherheits- und Gesundheitsanforderungen werden erfüllt durch Übereinstimmung mit

EN 60079-0:2012 + A11:2013 Allgemeine Anforderungen
EN 60079-11:2012 Eigensicherheit „I“

(10) Falls das Zeichen „X“ hinter der Bescheinigungsnummer steht, wird in der Anlage zu dieser Bescheinigung auf besondere Bedingungen für die sichere Anwendung des Gerätes hingewiesen.

(11) Diese EG-Baumusterprüfbescheinigung bezieht sich nur auf die Konzeption und die Baumusterprüfung des beschriebenen Gerätes in Übereinstimmung mit der Richtlinie 94/9/EG. Für Herstellung und Inverkehrbringen des Gerätes sind weitere Anforderungen der Richtlinie zu erfüllen, die nicht durch diese Bescheinigung abgedeckt sind.

(12) Die Kennzeichnung des Gerätes muss die folgenden Angaben enthalten:

 **II 1G Ex ia IIC T6 Ga**

DEKRA EXAM GmbH
Bochum, den 20.01.2016



 Zertifizierungsstelle



 Fachbereich



Seite 1 von 2 zu BVS 16 ATEX E 005
Dieses Zertifikat darf nur vollständig und unverändert weiterverbreitet werden.

DEKRA EXAM GmbH, Dinnendahlstraße 9, 44809 Bochum, Deutschland
Telefon +49.234.3696-105, Telefax +49.234.3696-110, zs-exam@dekra.com



(13) Anlage zur

(14) **EG-Baumusterprüfbescheinigung
BVS 16 ATEX E 005**

(15) 15.1 Gegenstand und Typ

Wägezelle Typ PR62**/**E

Anstelle der *** werden in der vollständigen Benennung Buchstaben und Ziffern eingefügt, die unterschiedliche Typen kennzeichnen:

Wägezelle Typ PR62 * * / * * E



Unterschiedliche Ausführungen (01, 02, 11, 12, 21, 41, 46, 51, 61), die sich elektrisch und / oder mechanisch unterscheiden

Laststufe (nicht Ex-relevant, nur für Informationszwecke)

15.2 Beschreibung

Die Wägezellen dienen zur Umwandlung von Kraft in ein elektrisches Signal. Die Zellen haben ein Metallgehäuse mit eingebauten Dehnungsmessstreifen. Der elektrische Anschluss erfolgt über eine fest angeschlossene Leitung. Die Zellen sind „einfache elektrische Betriebsmittel“.

15.3 Kenngrößen

Spannung	U _i	DC	25	V
Strom	I _i		160	mA
Leistung	P _i		2	W
Umgebungstemperaturbereich	T _a		-30 °C bis +55 °C	

(16) Prüfprotokoll

BVS PP 16.2012 EG, Stand 20.01.2016

(17) Besondere Bedingungen für die sichere Anwendung

Keine

Seite 2 von 2 zu BVS 16 ATEX E 005
Dieses Zertifikat darf nur vollständig und unverändert weiterverbreitet werden.

DEKRA EXAM GmbH, Dinnendahlstraße 9, 44809 Bochum, Deutschland
Telefon +49.234.3696-105, Telefax +49.234.3696-110, zs-exam@dekra.com





Translation

EC-Type Examination Certificate

- (1) **EC-Type Examination Certificate**
- (2) Equipment and protective systems intended for use in potentially explosive atmospheres - Directive 94/9/EC
- (3) No. of EC-Type Examination Certificate: **BVS 16 ATEX E 005**
- (4) Equipment: **Load cell type PR62**/*E**
- (5) Manufacturer: **Sartorius Mechatronics T&H GmbH**
- (6) Address: **Meiendorfer Straße 205, 22145 Hamburg, Germany**
- (7) The design and construction of this equipment and any acceptable variation thereto are specified in the appendix to this type examination certificate.
- (8) The certification body of DEKRA EXAM GmbH, notified body no. 0158 in accordance with Article 9 of the Directive 94/9/EC of the European Parliament and the Council of 23 March 1994, certifies that this equipment has been found to comply with the Essential Health and Safety Requirements relating to the design and construction of equipment and protective systems intended for use in potentially explosive atmospheres, given in Annex II to the Directive. The examination and test results are recorded in the Test and Assessment Report BVS PP 16.2012 EG.
- (9) The Essential Health and Safety Requirements are assured by compliance with:
 - EN 60079-0:2012 + A11:2013 General requirements**
 - EN 60079-11:2012 Intrinsic Safety "i"**
- (10) If the sign "X" is placed after the certificate number, it indicates that the equipment is subject to special conditions for safe use specified in the appendix to this certificate.
- (11) This EC-Type Examination Certificate relates only to the design, examination and tests of the specified equipment in accordance to Directive 94/9/EC. Further requirements of the Directive apply to the manufacturing process and supply of this equipment. These are not covered by this certificate.
- (12) The marking of the equipment shall include the following:

 **II 1G Ex ia IIC T6 Ga**

DEKRA EXAM GmbH
Bochum, dated 2016-01-20

Signed: Dr. Eickhoff

Signed: Dr. Wittler

Certification body

Special services unit



Page 1 of 2 of BVS 16 ATEX E 005
This certificate may only be reproduced in its entirety and without any change.
DEKRA EXAM GmbH, Dinnendahlstrasse 9, 44809 Bochum, Germany,
telephone +49.234.3696-105, Fax +49.234.3696-110, zs-exam@dekra.com



(13) Appendix to

(14) **EC-Type Examination Certificate**
BVS 16 ATEX E 005

(15) 15.1 Subject and type

Load cell type PR62**/**E

Instead of the *** in the complete denomination letters and numerals will be inserted which characterize different cell types:

Load cell type PR62

*	*
---	---

 /

*	*
---	---

 E

Different versions (01, 02, 11, 12, 21, 41, 46, 51, 61) which differ electrically and / or mechanically

Load level (not Ex relevant, for information purposes only)

15.2 Description

The load cells are used for converting a load into an electrical signal. The cells have a metal enclosure with inside fixed resistance strain gauges. The electrical connection is carried out by a permanently connected cable. The cells are "simple apparatus".

15.3 Parameters

Voltage	U _i	DC	25	V
Current	I _i		160	mA
Power	P _i		2	W
Ambient temperature range	T _a		-30 °C up to +55 °C	

(16) Test and Assessment Report

BVS PP 16.2012 EG as of 2016-01-20

(17) Special conditions for safe use

None

We confirm the correctness of the translation from the German original.
In the case of arbitration only the German wording shall be valid and binding.

DEKRA EXAM GmbH
44809 Bochum, 2016-01-20
BVS-/Hil/Schu/Mu A 20150360

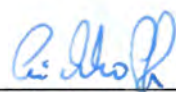

 Certification body



 Special services unit

Page 2 of 2 of BVS 16 ATEX E 005
This certificate may only be reproduced in its entirety and without any change.

DEKRA EXAM GmbH, Dinnendahlstrasse 9, 44809 Bochum, Germany,
telephone +49.234.3696-105, Fax +49.234.3696-110, zs-exam@dekra.com

12.2 IECEx BVS 16.0005



IECEX Certificate of Conformity

INTERNATIONAL ELECTROTECHNICAL COMMISSION
IEC Certification Scheme for Explosive Atmospheres
for rules and details of the IECEx Scheme visit www.iecex.com

Certificate No.:	IECEX BVS 16.0005	issue No.:1	Certificate history: Issue No. 1 (2017-7-6) Issue No. 0 (2016-1-21)
Status:	Current		
Date of Issue:	2017-07-06	Page 1 of 4	
Applicant:	Minebea Intec GmbH Meiendorfer Straße 205 22145 Hamburg Germany		
Equipment: <i>Optional accessory:</i>	Load cell type PR 62**/*E		
Type of Protection:	Equipment protection by intrinsic safety "i"		
Marking:	Ex ia IIC T6 Ga		
Approved for issue on behalf of the IECEx Certification Body:	Dr. F. Eickhoff		
Position:	Deputy Head of Certification Body		
Signature: <i>(for printed version)</i>	 <hr style="width: 100%;"/>		
Date:	2017-07-06 <hr style="width: 100%;"/>		

1. This certificate and schedule may only be reproduced in full.
 2. This certificate is not transferable and remains the property of the issuing body.
 3. The Status and authenticity of this certificate may be verified by visiting the Official IECEx Website.

Certificate issued by:

DEKRA EXAM GmbH
 Dinnendahlstrasse 9
 44809 Bochum
 Germany



DEKRA
On the safe side.



IECEx Certificate of Conformity

Certificate No.: IECEx BVS 16.0005

Date of Issue: 2017-07-06

Issue No.: 1

Page 2 of 4

Manufacturer: **Minebea Intec GmbH**
Meiendorfer Straße 205
22145 Hamburg
Germany

Additional Manufacturing location(s):

This certificate is issued as verification that a sample(s), representative of production, was assessed and tested and found to comply with the IEC Standard list below and that the manufacturer's quality system, relating to the Ex products covered by this certificate, was assessed and found to comply with the IECEx Quality system requirements. This certificate is granted subject to the conditions as set out in IECEx Scheme Rules, IECEx 02 and Operational Documents as amended.

STANDARDS:

The electrical apparatus and any acceptable variations to it specified in the schedule of this certificate and the identified documents, was found to comply with the following standards:

IEC 60079-0 : 2011 Explosive atmospheres - Part 0: General requirements
Edition: 6.0

IEC 60079-11 : 2011 Explosive atmospheres - Part 11: Equipment protection by intrinsic safety "i"
Edition: 6.0

*This Certificate **does not** indicate compliance with electrical safety and performance requirements other than those expressly included in the Standards listed above.*

TEST & ASSESSMENT REPORTS:

A sample(s) of the equipment listed has successfully met the examination and test requirements as recorded in

Test Report:
DE/BVS/ExTR16.0007/00

Quality Assessment Report:
DE/PTB/QAR13.0007/02

		<h2 style="text-align: right;">IECEx Certificate of Conformity</h2>	
Certificate No.:	IECEx BVS 16.0005	Issue No.:	1
Date of Issue:	2017-07-06	Page	3 of 4
Schedule			
EQUIPMENT:			
<i>Equipment and systems covered by this certificate are as follows:</i>			
General product information:			
<p>The load cells are used for converting a load into an electrical signal. The cells have a metal enclosure with inside fixed resistance strain gauges. The electrical connection is carried out by a permanently connected cable. The cells are "simple apparatus".</p>			
Technical parameters			
Voltage	Ui	DC	25 V
Current	Ii		160 mA
Power	Pi		2 W
Ambient temperature range	Ta		-30 °C up to +55 °C
Type Designation			
See Annex			
SPECIFIC CONDITIONS OF USE: NO			



IECEX Certificate of Conformity



Certificate No.:	IECEX BVS 16.0005	Issue No.:	1
Date of Issue:	2017-07-06	Page	4 of 4

DETAILS OF CERTIFICATE CHANGES (for issues 1 and above):

The reason for this new issue is the change of the company's name from Sartorius Mechatronics T&H GmbH to Minebea Intec GmbH. Therefore the appropriate QAR was linked to this certificate.

Annex: BVS_16_0005_Minebea_Annex_issue1.pdf

12.3 TÜV 03 ATEX 2301X

(1) **EU-Baumusterprüfbescheinigung**

(2) Geräte und Schutzsysteme zur bestimmungsgemäßen Verwendung in explosionsgefährdeten Bereichen, Richtlinie 2014/34/EU

(3) **Bescheinigungsnummer:** TÜV 03 ATEX 2301 X **Ausgabe:** 00

(4) für das Produkt: Wägezellen Typ PR 62.../.. und MP76/...

(5) des Herstellers: Minebea Intec GmbH

(6) Anschrift: Meiendorfer Str. 205 A, 22145 Hamburg

Auftragsnummer: 8000475687

Ausstellungsdatum: 14.11.2017

(7) Die Bauart dieses Produktes sowie die verschiedenen zulässigen Ausführungen sind in der Anlage und den darin aufgeführten Unterlagen zu dieser EU-Baumusterprüfbescheinigung festgelegt.

(8) Die TÜV NORD CERT GmbH bescheinigt als notifizierte Stelle Nr. 0044 nach Artikel 17 der Richtlinie 2014/34/EU des Europäischen Parlaments und des Rates vom 26. Februar 2014 die Erfüllung der wesentlichen Gesundheits- und Sicherheitsanforderungen für die Konzeption und den Bau dieses Produktes zur bestimmungsgemäßen Verwendung in explosionsgefährdeten Bereichen gemäß Anhang II der Richtlinie.
Die Ergebnisse der Prüfung sind in dem vertraulichen ATEX Prüfungsbericht Nr. 17 203 206448 festgelegt.

9) Die wesentlichen Gesundheits- und Sicherheitsanforderungen werden erfüllt durch Übereinstimmung mit:
EN 60079-0:2012+A11:2013 EN 60079-31:2014
ausgenommen die unter Abschnitt 18 der Anlage gelisteten Anforderungen.

(10) Falls das Zeichen "X" hinter der Bescheinigungsnummer steht, wird auf die Besonderen Bedingungen für die Verwendung des Produktes in der Anlage zu dieser Bescheinigung hingewiesen.

(11) Diese EU-Baumusterprüfbescheinigung bezieht sich nur auf Konzeption und Prüfung des festgelegten Produktes. Weitere Anforderungen dieser Richtlinie gelten für die Herstellung und das Bereitstellen dieses Produktes. Diese Anforderungen werden nicht durch diese Bescheinigung abgedeckt.

(12) Die Kennzeichnung des Produktes muss die folgenden Angaben enthalten:

 II 1 D Ex ta IIIC T160 °C Da

TÜV NORD CERT GmbH, Langemarkstraße 20, 45141 Essen, notifiziert durch die Zentralstelle der Länder für Sicherheitstechnik (ZLS), Ident. Nr. 0044, Rechtsnachfolger der TÜV NORD CERT GmbH & Co. KG Ident. Nr. 0032

Der Leiter der notifizierten Stelle

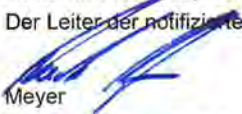
Meyer

Geschäftsstelle Hannover, Am TÜV 1, 30519 Hannover, Tel. +49 511 998-61455, Fax +49 511 998-61590

Diese Bescheinigung darf nur unverändert weiterverbreitet werden.
Auszüge oder Änderungen bedürfen der Genehmigung der TÜV NORD CERT GmbH

P17-F-001 Rev. 01/014.16
Seite 1/3

(13) **ANLAGE**(14) **EU-Baumusterprüfbescheinigung Nr. TÜV 03 ATEX 2301 X Ausgabe 00**

(15) Beschreibung des Produktes

Die Wägezellen Typen PR62../... und MP76/... gemäß der unten aufgeführten Tabelle dienen zur Messung von Kräften mittels einer DMS Brücke mit Kompensations- und Abgleichwiderständen. Die Gehäuse der Wägezellen sowie die eingesetzten Membranen bestehen aus Edelstahl. Alle Gehäuseteile und die Membranen sind gasdicht verschweißt.

Die Wägezellen dürfen in durch Staub explosionsgefährdeten Bereichen für EPL Da-Betriebsmittel bzw. EPL Db-Betriebsmittel installiert werden.

Der zulässige Umgebungstemperaturbereich beträgt -20 °C ... 55°C.

Auflistung der Typen und Gehäuseformen

Typen	Gehäuseform
PR 6201/...	Zylinder
PR 6202/...	Zylinder
PR 6203/...	Zylinder
PR 6221/...	Zylinder
PR 6211/...	Kreisplatte
PR 6212/...	Kreisplatte
PR 6251/...	Kreisplatte
PR 6261/...	Kreisplatte
PR 6241/...	S-Form
PR 6246/...	S-Form
MP 76/...	S-Form

Elektrische Daten

Versorgungs- und
Signalstromkreis
(fest angeschlossenes Kabel)

nur zum Anschluss an einen bescheinigten
eigensicheren Stromkreis

Höchstwert:

$P_i = 2 \text{ W}$

Die wirksame innere Induktivität und Kapazität sind vernachlässigbar klein.

Verwendung als EPL Da-Betriebsmittel

Schutzniveau des Stromkreises: ia

Verwendung als EPL Db-Betriebsmittel

Schutzniveau des Stromkreises: ia oder ib

(16) Zeichnungen und Dokumente sind im ATEX Prüfungsbericht Nr. 17 203 206448 aufgelistet.



Anlage zur EU-Baumusterprüfbescheinigung Nr. TÜV 03 ATEX 2103 X Ausgabe 00

(17) Besondere Bedingungen für die Verwendung

1. Die freien Leitungsenden der Anschlüsse sind außerhalb des explosionsgefährdeten Bereiches oder in einem geeigneten, für den Einsatz in durch Staub explosionsgefährdeten Bereichen bescheinigten Klemmenkasten zu verdrahten.

2. Der Anschluss von nichteigensicheren Stromkreisen

- mit einer sicheren Begrenzung der verfügbaren Leistung auf 2W und
 - einer sicheren galvanischen Trennung vom Erdpotential (für Wägezellen ohne zusätzlichen Erdanschluss erforderlich)
- an die Wägezellen mit EPL Db ist zulässig.

3. Die Wägezellen sind so zu errichten, dass die Gehäuse sicher mit Erdpotential verbunden sind (z. B. über die Erdungsklemme; die Betriebsanleitung des Herstellers ist zu beachten).

(18) Wesentliche Gesundheits- und Sicherheitsanforderungen

keine zusätzlichen

- Ende der Bescheinigung -

Translation
(1) **EU-Type Examination Certificate**



(2) Equipment and protective systems intended for use in potentially explosive atmospheres, **Directive 2014/34/EU**



(3) **Certificate Number** TÜV 03 ATEX 2301 X **issue:** 00

(4) for the product: Load cell type PR 62../... and MP76/...

(5) of the manufacturer: Minebea Intec GmbH
(6) Address: Meiendorfer Str. 205 A, 22145 Hamburg

Order number: 8000475687

Date of issue: 2017-11-14

(7) The design of this product and any acceptable variation thereto are specified in the schedule to this EU-Type Examination Certificate and the documents therein referred to.

(8) The TÜV NORD CERT GmbH, Notified Body No. 0044, in accordance with Article 17 of the Directive 2014/34/EU of the European Parliament and the Council of 26 February 2014, certifies that this product has been found to comply with the Essential Health and Safety Requirements relating to the design and construction of products intended for use in potentially explosive atmospheres given in Annex II to the Directive.
The examination and test results are recorded in the confidential ATEX Assessment Report No. 17 203 206448.

(9) Compliance with the Essential Health and Safety Requirements has been assured by compliance with:
EN 60079-0:2012+A11:2013 EN 60079-31:2012

except in respect of those requirements listed at item 18 of the schedule.

(10) If the sign "X" is placed after the certificate number, it indicates that the product is subject to the Specific Conditions for Use specified in the schedule to this certificate.

11) This EU-Type Examination Certificate relates only to the design, and construction of the specified product. Further requirements of the Directive apply to the manufacturing process and supply of this equipment. These are not covered by this certificate.

(12) The marking of the product shall include the following:

II 1 D Ex ta IIIC T160 °C Da

TÜV NORD CERT GmbH, Langemarckstraße 20, 45141 Essen, notified by the central office of the countries for safety engineering (ZLS), Ident. Nr. 0044, legal successor of the TÜV NORD CERT GmbH & Co. KG Ident. Nr. 0032

The head of the notified body

Meyer

Hanover office, Am TÜV 1, 30519 Hannover, Tel. +49 511 998-61455, Fax +49 511 998-61590

This certificate may only be reproduced without any change, schedule included.
Excerpts or changes shall be allowed by the TÜV NORD CERT GmbH



(13) **SCHEDULE**

(14) **EU-Type Examination Certificate No. TÜV 03 ATEX 2301 X issue 00**

(15) Description of product

The load cells type PR62../... and MP76/... according to the table mentioned below are used for measuring forces by means of a strain gauge with resistors for compensation and adjustment.
 The housings of the load cells as well as the used membranes consist of stainless steel. All parts of the housing and the membranes are welded gas-tight.
 The load cells are allowed to be installed in explosion hazardous areas caused by dust for EPL Da apparatus resp. for EPL Db apparatus.
 The permissible ambient temperature range is -20 °C ... 55 °C.

Listing of types and shape of housings

Types	Shape of housing
PR 6201/...	Cylinder
PR 6202/...	Cylinder
PR 6203/...	Cylinder
PR 6221/...	Cylinder
PR 6211/...	Circle plate
PR 6212/...	Circle plate
PR 6251/...	Circle plate
PR 6261/...	Circle plate
PR 6241/...	S-shape
PR 6246/...	S-shape
MP 76/...	S-shape

Supply- and signal circuit
 (Cable connected fixed)

only for connection to a certified intrinsically safe circuit
 Maximum value:
 $P_i = 2 \text{ W}$
 The effective internal inductance and capacitance are negligibly small.
Use as EPL Da apparatus
 Level of protection of the circuit: ia
Use as EPL Db apparatus
 Level of protection of the circuit: ia or ib

(16) Drawings and documents are listed in the ATEX Assessment Report No. 17 203 206448



Schedule to EU-Type Examination Certificate No. TÜV 03 ATEX 2301 X issue 00

(17) Specific Conditions for Use

1. The free cable ends of the connections have to be wired outside of the explosion hazardous area or in a suitable terminal box, suitably certified for the application in explosion hazardous areas caused by dust.

2. The connection of non-intrinsically safe circuits

- with a safe limitation of the available power of 2 W and

- a safe galvanic separation from earth potential (necessary for load cells without an additional earth connection)

to the load cells of EPL Db is permissible.

3. The load cells have to be installed in such a way, that the housings are safely connected with earth potential (e. g. via the earth terminal; observe manual of the manufacturer).

(18) Essential Health and Safety Requirements



no additional ones

- End of Certificate -

12.4 IECEx TUN 17.0025X

		<h2 style="text-align: right;">IECEX Certificate of Conformity</h2>	
<p>INTERNATIONAL ELECTROTECHNICAL COMMISSION IEC Certification Scheme for Explosive Atmospheres <small>for rules and details of the IECEx Scheme visit www.iecex.com</small></p>			
Certificate No.:	IECEX TUN 17.0025X	issue No.:0	Certificate history:
Status:	Current		
Date of Issue:	2017-11-14	Page 1 of 3	
Applicant:	Minebea Intec GmbH Meiendorfer Str. 205 22145 Hamburg Germany		
Equipment: <i>Optional accessory:</i>	Weighing cells type PR 62.. /... and MP76/...		
Type of Protection:	Equipment dust ignition protection by enclosure "t"		
Marking:	Ex ta IIIC T160°C Da		
Approved for issue on behalf of the IECEx Certification Body:	Andreas Meyer		
Position:	Head of IECEx Certification Body		
Signature: <i>(for printed version)</i>			
Date:			
1. This certificate and schedule may only be reproduced in full. 2. This certificate is not transferable and remains the property of the issuing body. 3. The Status and authenticity of this certificate may be verified by visiting the Official IECEx Website .			
Certificate issued by:			
TÜV NORD CERT GmbH Hanover Office Am TÜV 1, 30519 Hannover Germany			

	IECEX Certificate of Conformity	
Certificate No.:	IECEX TUN 17.0025X	Issue No.: 0
Date of Issue:	2017-11-14	Page 2 of 3
Manufacturer:	Minebea Intec GmbH Meiendorfer Str. 205 22145 Hamburg Germany	
Additional Manufacturing location(s):		
<p>This certificate is issued as verification that a sample(s), representative of production, was assessed and tested and found to comply with the IEC Standard list below and that the manufacturer's quality system, relating to the Ex products covered by this certificate, was assessed and found to comply with the IECEx Quality system requirements. This certificate is granted subject to the conditions as set out in IECEx Scheme Rules. IECEx 02 and Operational Documents as amended.</p>		
STANDARDS: The electrical apparatus and any acceptable variations to it specified in the schedule of this certificate and the identified documents, was found to comply with the following standards:		
IEC 60079-0 : 2011 Edition: 6.0	Explosive atmospheres - Part 0: General requirements	
IEC 60079-31 : 2013 Edition: 2	Explosive atmospheres - Part 31: Equipment dust ignition protection by enclosure "I"	
<p><i>This Certificate does not indicate compliance with electrical safety and performance requirements other than those expressly included in the Standards listed above.</i></p>		
TEST & ASSESSMENT REPORTS: A sample(s) of the equipment listed has successfully met the examination and test requirements as recorded in		
<u>Test Report:</u> DE/TUN/EXTR17.0023/00		
<u>Quality Assessment Report:</u> DE/PTB/QAR13.0007/02		

IECEX Certificate of Conformity

Certificate No.:	IECEX TUN 17.0025X	
Date of Issue:	2017-11-14	Issue No.: 0
		Page 3 of 3

Schedule

EQUIPMENT:
Equipment and systems covered by this certificate are as follows:

The load cells type PR62./... and MP76/... according to the table mentioned below are used for measuring forces by means of a strain gauge with resistors for compensation and adjustment.
 The housings of the load cells as well as the used membranes consist of stainless steel. All parts of the housing and the membranes are welded gas-tight.
 The load cells are allowed to be installed in explosion hazardous areas caused by dust for EPL Da apparatus resp. for EPL Db apparatus.
 The permissible ambient temperature range is -20 °C ... +55 °C.

See attachment for further details.

SPECIFIC CONDITIONS OF USE: YES as shown below:

- 1.The free cable ends of the connections have to be wired outside of the explosion hazardous area or in a suitable terminal box, certified for the application in explosion hazardous areas caused by dust.
- 2.The connection of non intrinsically safe circuits
 - with a safe limitation of the available power of 2W and
 - a safe galvanic separation from earth potential (necessary for load cells without an additional earth connection)
 to the load cells of the category 2 is permissible.
- 3.The load cells have to be installed in such a way, that the housings are connected with earth potential.

Annex: _Attachment_load cells TUN 17.0025 X (2).pdf

TÜV NORD CERT GmbH
 Hanover Office
 Am TÜV 1
 30519 Hannover
 Germany



Page 1 of 1
 Attachment to IECEx TUN 17.0025 X issue 00

The load cells type PR62./... and MP76/... according to the table mentioned below are used for measuring forces by means of a strain gauge with resistors for compensation and adjustment. The housings of the load cells as well as the used membranes consist of stainless steel. All parts of the housing and the membranes are welded gas-tight. The load cells are allowed to be installed in explosion hazardous areas caused by dust for category 1 apparatus resp. for category 2 apparatus. The permissible ambient temperature range is -20 °C ... 55 °C.

Listing of types and shape of housings

Types	Shape of housing
PR 6201/...	Cylinder
PR 6202/...	Cylinder
PR 6203/...	Cylinder
PR 6221/...	Cylinder
PR 6211/...	Circle plate
PR 6212/...	Circle plate
PR 6251/...	Circle plate
PR 6261/...	Circle plate
PR 6241/...	S-shape
PR 6246/...	S-shape
MP 76/...	S-shape

Supply- and signal circuit
 (Cable connected fixed)

only for connection to a certified intrinsically safe circuit

Maximum value:
 $P_i = 2 \text{ W}$

The effective internal inductance and capacitance are negligibly small.

Use as category 1 apparatus

Level of protection of the circuit: ia

Use as category 2 apparatus

Level of protection of the circuit: ia or ib

Specific Conditions of Use

1. The free cable ends of the connections have to be wired outside of the explosion hazardous area or in a suitable terminal box, suitably certified for the application in explosion hazardous areas caused by dust.
2. The connection of non intrinsically safe circuits
 - with a safe limitation of the available power of 2 W and
 - a safe galvanic separation from earth potential (necessary for load cells without an additional earth connection)
 to the load cells of the category 2 is permissible.
3. The load cells have to be installed in such a way, that the housings are safely connected with earth potential (e. g. via the earth terminal; observe manual of the manufacturer).

12.5 MIN16ATEX001X

	Herstellerbescheinigung Manufacturer's certificate	
Nummer Number	MIN16ATEX001X	
Hersteller Manufacturer	Minebea Intec GmbH Meiendorfer Straße 205A 22145 Hamburg, Germany	
	erklärt in alleiniger Verantwortung, dass das Produkt <i>declares under sole responsibility that the product</i>	
Geräteart Device type	Wägezelle <i>Load cell</i>	
Baureihe Type series	PR 6201, PR 6202, PR 6203, PR 6207, PR 6211 D1(500kg-10t), PR 6212, PR 6221, PR 6241, PR 6246, PR 6251, PR 6261, MP 76 (ohne Typ / without type LA or LT)	
	auf das sich diese Bescheinigung bezieht, mit der/den folgenden Norm(en) oder normativen Dokument(en) übereinstimmt (siehe Seite 2) gemäß den Bestimmungen der „Richtlinie 2014/34/EU des Europäischen Parlaments und des Rates vom 26. Februar 2014 zur Harmonisierung der Rechtsvorschriften der Mitgliedstaaten für Geräte und Schutzsysteme zur bestimmungsgemäßen Verwendung in explosionsgefährdeten Bereichen“. Das Produkt wird wie folgt gekennzeichnet: <i>to which this certification relates is in conformity with the following standard(s) or other normative document(s) (see page 2) pursuant to the provisions of the "Directive 2014/34/EU of the European Parliament and of the Council of 26 February 2014 on the harmonisation of the laws of the Member States relating to equipment and protective systems intended for use in potentially explosive atmospheres ". This product is labelled as follows:</i>	
Kennzeichnung Marking	II 3G Ex nA IIC T6 Gc II 3D Ex tc IIIC T85°C Dc MIN16ATEX001X	
	Minebea Intec GmbH Hamburg, 09.03.2020	
		
	W.D. Schulze Managing Director	Torben Hiller EX Approval Manager
	Diese Erklärung bescheinigt die Übereinstimmung mit den genannten EU-Richtlinien, ist jedoch keine Zusicherung von Eigenschaften. Bei einer mit uns nicht abgestimmten Änderung des Produktes verliert diese Erklärung ihre Gültigkeit. Die Sicherheitshinweise der zugehörigen Produktdokumentation sind zu beachten. <i>This declaration certifies conformity with the above mentioned EC Directives, but does not guarantee product attributes. Unauthorized product modifications make this declaration invalid. The safety information in the associated product documentation must be observed.</i>	
	1/2 MIN16ATEX001X Rev. 3	



Herstellerbescheinigung Manufacturer's certificate



Die grundlegenden Sicherheits- und Gesundheitsanforderungen werden erfüllt durch Übereinstimmung mit:

Compliance with the Essential Health and Safety Requirements has been assured by compliance with:

Normen Standards

EN 60079-0:2012 + A11:2013

Explosionsgefährdete Bereiche – Teil 0: Geräte – Allgemeine Anforderungen
Explosive atmospheres – Part 0: Equipment – General requirements

EN 60079-15:2010

Explosionsfähige Atmosphäre – Teil 15: Geräteschutz durch Zündschutzart „n“
Explosive atmospheres – Part 15: Equipment protection by type of protection „n“

EN 60079-31:2014

Explosionsfähige Atmosphäre – Teil 31: Geräte-Staubexplosionsschutz durch Gehäuse „t“
Explosive atmospheres – Part 31: Equipment dust ignition protection by enclosure „t“

Diese Bescheinigung wurde auf Basis des folgenden Prüfberichts erstellt:

This certificate was drawn on the basis of the following test report:

Prüfbericht Test Report

MTR0001

Minebea Intec GmbH, Hamburg, Germany

Sicherheitshinweise Safety instructions

949905947901

Umgebungstemperatur Ambient temperature

-30°C ... +55°C

IP-Schutz IP protection

IP6X

Für diese Produkt gelten folgende besonderen Bedingungen für den sicheren Gebrauch:

For this product the following special conditions for safe use apply:

besondere Bedingungen special Conditions

Für Anwendungen in Umgebungen mit brennbaren Stäuben ist eine elektrostatische Aufladung zu vermeiden.

For application in environments with combustible dust, electrostatic charging shall be avoided.

Bei Verwendung der Zündschutzart "Ex nA" ist eine Transientenschutzvorrichtung vorzusehen welche einen Maximalwert von 140% des Spitzenspannungswertes von 85V sicherstellt.

When applied in type of protection non sparking "Ex nA", a transient protection device shall be set at a level not exceeding 140% of the peak rated voltage value of 85 V.

12.6 FM17CA0138



CERTIFICATE OF CONFORMITY

1. HAZARDOUS LOCATION ELECTRICAL EQUIPMENT PER CANADIAN REQUIREMENTS
2. Certificate No: FM17CA0138
3. Equipment: (Type Reference and Name) Model PR 6201, PR 6202, PR 6203, PR 6211, PR 6212, PR 6221, PR 6241, PR 6246, PR 6251, PR 6261 Load Cells
4. Name of Listing Company: Minebea Intec GmbH
5. Address of Listing Company: Meien dorfer Str. 205A
22145 Hamburg
Germany
6. The examination and test results are recorded in confidential report number:

3053046 dated 22nd July 2014
7. FM Approvals LLC, certifies that the equipment described has been found to comply with the following Approval standards and other documents:

CAN/CSA-C22.2 No. 213: 2013, CAN-C22.2 No. 157-92: 2012,
CSA-C22.2 No. 1010.1: 2004, CAN/CSA-C22.2 No. 25: 2009
8. If the sign 'X' is placed after the certificate number, it indicates that the equipment is subject to specific conditions of use specified in the schedule to this certificate.
9. This certificate relates to the design, examination and testing of the products specified herein. The FM Approvals surveillance audit program has further determined that the manufacturing processes and quality control procedures in place are satisfactory to manufacture the product as examined, tested and Approved.
10. Equipment Ratings:

Intrinsically safe (Entity) for use in Class I, II and III Division 1, Groups A, B, C, D, E, F and G indoor and outdoor Hazardous Locations, Temperature Class T4A Ta= -40°C to +70°C and T5 Ta= -40°C to +55°C when installed per Control Drawing 4012 101 5688.
Nonincendive (NIFW) for use in Class I, Division 2, Groups A, B, C, and D indoor and outdoor Hazardous Locations, Temperature Class T4A Ta= -40°C to +70°C and T5 Ta= -40°C to +55°C when installed per Control Drawing 4012 101 5688.

Certificate issued by:



J.E. Marquardt
VP, Manager - Electrical Systems

30 July 2020
Date

To verify the availability of the Approved product, please refer to www.fmaprovals.com

THIS CERTIFICATE MAY ONLY BE REPRODUCED IN ITS ENTIRETY AND WITHOUT CHANGE

FM Approvals LLC, 1151 Boston-Providence Turnpike, Norwood, MA 02062 USA
T: +1 (1) 781 762 4300 F: +1 (1) 781 762 9375 E-mail: information@fmaprovals.com www.fmaprovals.com

F 349 (Mar 16)
Page 1 of 3

<u>SCHEDULE</u>	
	
Canadian Certificate Of Conformity No: FM17CA0138	
Dust Ignition protected for Class II, III Division 2, Groups E, F and G indoor and outdoor Hazardous Locations, Temperature Class T4A Ta= -40°C to +70°C and T5 Ta= -40°C to +55°C when installed per Control Drawing 4012 101 5688	
11. The marking of the equipment shall include:	IS CL I, II, III, DIV 1, GP A,B,C,D,E,F,G Entity - 4012 101 5688 NI CL I, II, III, DIV 2, GP A,B,C,D, E, F, G - 4012 101 5688; NIFW T4A Ta= -40°C to 70°C; T5 Ta= -40°C to 55°C
12. Description of Equipment:	<p>General - The Model PR 62xx Series Load Cells are precision compression load cells designed to meet the specific requirements of a wide range of weighing installations.</p> <p>Construction - The Model PR 62xx Series Load Cells are constructed of welded stainless steel, hermetically sealed, and filled with inert gas.</p> <p>Ratings - The Model PR 62xx Series Load Cells are rated for an operating temperature range of -40°C to 70°C. Entity and Nonincendive Field Wiring parameters are as defined below.</p> <p>PR 62a/bc d e. Load Cell.</p> <p>Entity/Nonincendive Field Wiring Parameters: Ui = 25 V, li = 160 mA, Pi = 2 W; Ci= 0 µF, Li= 0 mH.</p> <p>a = 01, 02, 03, 11, 12, 21, 41, 46, 51, 61 b = up to three numbers denoting the maximum capacity (may be separated by a dot) c = Unit of measurement: blank or t d = Accuracy: up to three numbers or letters (may be separated by dots) e = Special: F or blank</p>
13. Specific Conditions of Use:	None
14. Test and Assessment Procedure and Conditions:	This Certificate has been issued in accordance with FM Approvals Canadian Certification Scheme.
15. Schedule Drawings	A copy of the technical documentation has been kept by FM Approvals.
16. Certificate History	Details of the supplements to this certificate are described below:
<u>THIS CERTIFICATE MAY ONLY BE REPRODUCED IN ITS ENTIRETY AND WITHOUT CHANGE</u>	
FM Approvals LLC, 1151 Boston-Providence Turnpike, Norwood, MA 02062 USA T: +1 (1) 781 762 4300 F: +1 (1) 781 762 9375 E-mail: information@fmapprovals.com www.fmapprovals.com	
F 348 (Mar 16)	Page 2 of 3

SCHEDULE



Canadian Certificate Of Conformity No: FM17CA0138

Date	Description
22 nd July 2014	Original Issue.
6 th October 2017	<u>Supplement 3:</u> Report Reference: – RR210028 dated 6 th October 2017. Description of the Change: Company name change from Sartorius Mechatronics T&H GmbH. Certificate reformed.
10 th November 2017	<u>Supplement 4:</u> Report Reference: – RR211742 dated 10 th November 2017. Description of the Change: Addition of option a = 03.
24 th October 2018	<u>Supplement 5:</u> Report Reference: – RR215447 dated 24 th October 2018 . Description of the Change: Update lower operating temperatures from -30°C to -40°C.
30 th July 2020	<u>Supplement 6:</u> Report Reference: – RR224030 dated 30 th July 2020. Description of the Change: Added load cell variation PR 6261.



THIS CERTIFICATE MAY ONLY BE REPRODUCED IN ITS ENTIRETY AND WITHOUT CHANGE

FM Approvals LLC, 1151 Boston-Providence Turnpike, Norwood, MA 02062 USA
 T: +1 (1) 781 762 4300 F: +1 (1) 781 762 9375 E-mail: information@fmapprovals.com www.fmapprovals.com

F 348 (Mar 16)

Page 3 of 3

12.7 FM17US0276



CERTIFICATE OF CONFORMITY

1. HAZARDOUS (CLASSIFIED) LOCATION ELECTRICAL EQUIPMENT PER US REQUIREMENTS
2. Certificate No: FM17US0276
3. Equipment: Model PR 6201, PR 6202, PR 6203, PR 6211, PR 6212, PR 6221, PR 6241, PR 6246, PR 6251, PR 6261 Load Cells
(Type Reference and Name)
4. Name of Listing Company: Minebea Intec GmbH
5. Address of Listing Company: Majendorfer Str. 205A
22145 Hamburg
Germany
6. The examination and test results are recorded in confidential report number:

3001200 dated 12th August 1999
7. FM Approvals LLC, certifies that the equipment described has been found to comply with the following Approval standards and other documents:

FM Class 3600:2018, FM Class 3610:2010, FM Class 3611:2004, FM Class 3810:2005
8. If the sign 'X' is placed after the certificate number, it indicates that the equipment is subject to specific conditions of use specified in the schedule to this certificate.
9. This certificate relates to the design, examination and testing of the products specified herein. The FM Approvals surveillance audit program has further determined that the manufacturing processes and quality control procedures in place are satisfactory to manufacture the product as examined, tested and Approved.
10. Equipment Ratings:

Intrinsically safe (Entity) for use in Class I, II and III Division 1, Groups A, B, C, D, E, F and G indoor and outdoor Hazardous (C classified) Locations, Temperature Class T4A Ta= -40°C to +70°C and T5 Ta= -40°C to +55°C when installed per Control Drawing 4012 101 5688.
Nonincendive (NIFW) for use in Class I, II and III Division 2, Groups A, B, C, D, E, F and G indoor and outdoor Hazardous (C classified) Locations, Temperature Class T4A Ta= -40°C to +70°C and T5 Ta= -40°C to +55°C when installed per Control Drawing 4012 101 5688.

Certificate issued by:

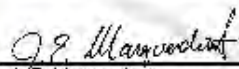

 J/E. Marquardt
 VP, Manager - Electrical Systems

 30 July 2020
 Date

To verify the availability of the Approved product, please refer to www.fmaprovalsguide.com

THIS CERTIFICATE MAY ONLY BE REPRODUCED IN ITS ENTIRETY AND WITHOUT CHANGE

FM Approvals LLC, 1151 Boston-Providence Turnpike, Norwood, MA 02062 USA
 T: +1 (1) 781 762 4300 F: +1 (1) 781 762 9375 E-mail: inquiries@fmaprovals.com, www.fmaprovals.com

F 347 (Mar 16) Page 1 of 3



SCHEDULE

US Certificate Of Conformity No: FM17US0276

11. The marking of the equipment shall include:

IS CL I, II, III, DIV 1, GP A,B,C,D,E,F,G Entity - 4012 101 5688
 NI CL I, II, III, DIV 2, GP A,B,C,D,E,F,G - 4012 101 5688; NIFW
 T4A Ta= -40°C to 70°C; T5 Ta= -40°C to 55°C

12. **Description of Equipment:**

General - The Model PR 62xx Series Load Cells are precision compression load cells designed to meet the specific requirements of a wide range of weighing installations.

Construction - The Model PR 62xx Series Load Cells are constructed of welded stainless steel, hermetically sealed, and filled with inert gas.

Ratings - The Model PR 62xx Series Load Cells are rated for an operating temperature range of -40°C to 70°C. Entity and Nonincendive Field Wiring parameters are as defined below.

PR 62a/bc d e. Load Cell.

Entity/Nonincendive Field Wiring Parameters:
 Ui = 25 V, Ii = 160 mA, Pi = 2 W; Ci = 0 µF, Li = 0 mH.

a = 01, 02, 03, 11, 12, 21, 41, 46, 51, 61
 b = up to three numbers denoting the maximum capacity (may be separated by a dot)
 c = Unit of measurement: blank or t
 d = Accuracy: up to three numbers or letters (may be separated by dots)
 e = Special: F or blank

13. **Specific Conditions of Use:**

None

14. **Test and Assessment Procedure and Conditions:**

This Certificate has been issued in accordance with FM Approvals US Certification Requirements.

15. **Schedule Drawings**

A copy of the technical documentation has been kept by FM Approvals.

THIS CERTIFICATE MAY ONLY BE REPRODUCED IN ITS ENTIRETY AND WITHOUT CHANGE

FM Approvals LLC, 1151 Boston-Providence Turnpike, Norwood, MA 02062 USA
 T: +1 (1) 781 762 4300 F: +1 (1) 781 762 9375 E-mail: information@fmaprovals.com www.fmaprovals.com

F 347 (Mar 16) Page 2 of 3

SCHEDULE

US Certificate Of Conformity No: FM17US0276



Member of the FM Global Group

16. Certificate History

Details of the supplements to this certificate are described below:

Date	Description
12 th August 1999	Original Issue.
6 th October 2017	<u>Supplement 7:</u> Report Reference: – RR210028 dated 6 th October 2017. Description of the Change: Company name change from Sartorius Mechatronics T&H GmbH. Certificate reformed.
10 th November 2017	<u>Supplement 8:</u> Report Reference: – RR211742 dated 10 th November 2017. Description of the Change: Addition of option a = 03.
24 th October 2018	<u>Supplement 9:</u> Report Reference: – RR215447 dated 24 th October 2018. Description of the Change: Update lower operating temperatures from -30°C to -40°C. Update FM Class 3600 from 2011 to 2018.
30 th July 2020	<u>Supplement 10:</u> Report Reference: – RR224030 dated 30 th July 2020. Description of the Change: Added load cell variation PR 6261.

THIS CERTIFICATE MAY ONLY BE REPRODUCED IN ITS ENTIRETY AND WITHOUT CHANGE

FM Approvals LLC, 1151 Boston-Providence Turnpike, Norwood, MA 02062 USA
T: +1 (1) 781 762 4300 F: +1 (1) 781 762 9375 E-mail: information@fmaprovals.com www.fmaprovals.com

F 347 (Mar 16)
Page 3 of 3

12.8 4012 101 5688

Hazardous (Classified) Location
Class I, II, III, Division 1, Groups A,B,C,D,E,F,G

Minebea Intec
Load Cell Series PR62.1

$U_i = 25V, l_i = 0.16A$
 $P_i = 2W$
 $L_i = 0, C_i = 0$

FM Approved Apparatus (USA) or product is suitably certified for use in Canada with Entity Concept parameters (see note 5) (V_o, I_o, C_o, L_o) appropriate for connection to intrinsically safe apparatus with Entity Concept parameters.

Hazardous (Classified) Location
Class I, II, III, Division 2, Groups A,B,C,D,E,F,G

Minebea Intec
Load Cell Series PR62.2

$V_{max} = 25V$

FM Approved Apparatus (USA) or product is suitably certified for use in Canada with nonincendive field wiring and output voltage of $25V_{max}$ to the load cells.

Notes

- In the **USA**: The installation must be in accordance with the National Electrical Code[®], NFPA 70 and ANSI / ISA-RP 12.06.01.
In **Canada**: The installation must be in accordance with the Canadian Electrical Code[®], Part 1.
- The apparatus must not be connected to any device that uses or generates in excess of 250Vrms or DC.
 $U_{0n} = 250V$.
- In the **USA**: The Apparatus must be connected to a suitable ground electrode per National Electrical Code[®], NFPA 70, Article 504. The resistance of the ground pad must be less than 1 ohm.
In **Canada**: The Apparatus must be connected to a suitable ground electrode per Canadian Electrical Code[®], Part 1. The resistance of the ground pad must be less than 1 ohm.
The load cell ground (housing) must be insulated from the surface on which it is mounted or be at the same potential of the NRTL approved apparatus ground as per installation drawings.
- Connection must be made in accordance with the manufacturer's instructions** of the NRTL approved apparatus.
- The Entity Concept allows interconnection of intrinsically safe apparatus with associated apparatus not specifically examined in combination as a system when the approved values of V_o and I_o of the associated apparatus are less than or equal to V_i and I_i of the intrinsically safe apparatus and the approved values of C_o and L_o of the associated apparatus are greater than C_i and L_i of the intrinsically safe apparatus plus all cable parameters.
- Ambient temperature range:
 $-40^{\circ}C \dots +55^{\circ}C$ ($-40^{\circ}F \dots +131^{\circ}F$) for T5 and $-40^{\circ}C \dots +70^{\circ}C$ ($-40^{\circ}F \dots +158^{\circ}F$) for T4A.
- WARNING:** SUBSTITUTION OF COMPONENTS MAY IMPAIR INTRINSIC SAFETY
AVERTISSEMENT: LA SUBSTITUTION DE COMPOSANTS PEUT COMPROMETTRE LA SÉCURITÉ INTRINSÈQUE

	Datum Date	Name	Material				Maßstab / Scale
Erstellt Written by	20.08.18	Schallhorn	Minebea <i>intec</i>		Benennung / Title		1:1
Geprüft Reviewed by	20.08.18	Hiller			Load Cells Series PR62..		1
Freigabe Released by	20.08.18	Schallhorn	Ausgabe / Revision 04	Änderung / Alteration PA50180542	Zeichnungs-Nr. / Drawing number 4012 101 5688	Teildok. Nr. / Part doc. no 592	1

Wiedergabe sowie Vervielfältigung dieses Dokuments, Verwertung und Mitteilung seines Inhaltes sind verboten, soweit nicht ausdrücklich gestattet. Zuwiderhandlungen verpflichten zu Schadensersatz. Alle Rechte für den Fall der Patent-, Gebrauchsmuster- oder Geschmacksmusterertragung vorbehalten.

The copying, distribution and utilization of this document as well as the communication of its contents to others without expressed authorization is prohibited. Offenders will be held liable for the payment of damages. All rights reserved in the event of the grant of a patent, utility model or ornamental design registration.

12.9 MEU17027



MEU17027

EU-Declaration of Conformity



1. Product model / product number / solely valid for project number:
 Compression Type Load Cell / PR 6201 / ---
2. Name and address of the manufacturer (2.1) and his authorized representative (2.2):
 2.1 Minebea Intec GmbH, Meiendorfer Straße 205 A, 22145 Hamburg, Germany
 2.2 /
3. This declaration of conformity is issued under the sole responsibility of the manufacturer.
4. Object(s) of the declaration:
 4.1 PR 6201
 4.2 PR 6201 (A.1)
 4.3 PR 6201 (A.2)
 4.4 PR 6201/___E
 4.5 PR 6201/___LA
5. The object(s) of the declaration described above is in conformity with the relevant Union harmonization legislation:

	(4.1)	(4.2)	(4.3)	(4.4)	(4.5)
5.1 2014/30/EU	(6.1)	(6.1)	(6.1)	(6.1)	(6.1)
5.2 2011/65/EU	(6.2)	(6.2)	(6.2)	(6.2)	(6.2)
5.3 2014/34/EU		(6.3)	(6.4)	(6.5)	
6. References to the relevant harmonized standards used or references to the other technical specifications in relation to which conformity is declared:
 6.1 2014/30/EU EN 61326-1:2013, EN 61000-4-20:2010
 6.2 2011/65/EU EN 50581:2012
 6.3 2014/34/EU EN 60079-0:2012+A11:2013, EN 60079-15:2010, EN 60079-31:2014
 6.4 2014/34/EU EN 60079-0:2012+A11:2013, EN 60079-31:2014
 6.5 2014/34/EU EN 60079-0:2012+A11:2013, EN 60079-11:2012
7. The notified body w performed x and issued the certificate y relevant for z:

	w	x	y	z
7.1 /		Manufacturer's certificate	MIN16ATEX001X	(4.2)
7.2 0032		EC-Type Examination Certificate	TÜV 03 ATEX 2301 X	(4.3)
7.3 0158		EC-Type Examination Certificate	BVS 16 ATEX E 005	(4.4)
7.4 0102		Production Quality Assessment Notification	PTB 02 ATEX Q010	(4.3), (4.4)

Minebea Intec GmbH
 Hamburg, 29. May. 2017



Dr. Bodo Krebs
President



Oliver Freitag
CE Certification

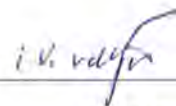

Kay v.d. Heydt
Ex Approval Manager

1/6



EU-Declaration of Conformity



A. Additional information on ():

A.1	(7.1)	Marking		II 3G Ex nA IIC T6 Gc II 3D Ex tc IIIC T85°C Dc MIN. 16 ATEX 001 X
A.2	(7.2)	Marking		II 1 D Ex t IIIC T ₅₀₀ 77 °C Da IP 65 TÜV 03 ATEX 2301 X
A.3	(7.3)	Marking		II 1G Ex ia IIC T6 Ga BVS 16 ATEX E 005
A.4	(6.4)	The above-mentioned product is in line with the requirements of the directive 2014/34/EU. One or more of the European Standards mentioned are already replaced by new editions. The manufacturer declares that the product also complies with these new editions, as the changed requirements of the new Standards do not affect the product.		



EU-Declaration of Conformity



MEU17027

Български (bg)
 Декларация за съответствие
 1. Модел на продукта / Номер на продукта / какъвто е само за номера на проекта:
 2. Наименование и адрес на производителя (2.1) и на неговия упълномощен представител (2.2)
 3. Настоящата декларация за съответствие е издадена на отговорността на производителя.
 4. Предмет(и) на декларацията:
 5. Предметът (ите) на декларацията, описан(и) по-горе отговаря(т) на съответното законодателство на Съюза за хармонизиране.
 6. Посочване на приложимите хармонизирани стандарти или позоваване на други технически спецификации, по отношение на които се декларира съответствие.
 7. Означеният орган в извършил и издаде сертификата у, отнасят се за:
 A. Допълнителна информация за ():
 A.1 Маркировка
 A.2 Маркировка
 A.3 Маркировка
 A.4 Горепосоченият продукт съответства на изискванията на Директива 2014/34/ЕС, Емн или повече от приложимите европейски стандарти вече са заменени от нови издания. Производителят декларира, че продуктът съответства и на тези нови издания, тъй като промените изисквания на новите стандарти не засягат продукта.

Сетина (cs)
 Prohlášení o shodě
 1. Model výrobku / číslo výrobku / platné pouze pro číslo projektu:
 2. Jméno a adresa výrobce (2.1) a jeho zplnomocněného zástupce (2.2)
 3. Toto prohlášení o shodě se vydává na vylučující odpovědnost výrobce.
 4. Předmět(y) prohlášení:
 5. Výše popsaný předmět / Výše popsané předměty prohlášení je/ jsou ve shodě s příslušnými harmonizačními právními předpisy Unie.
 6. Odhady na příslušné harmonizační normy, které byly použity, nebo na jiné technické specifikace, na jejichž základě se shoda prohlašuje.
 7. Označený subjekt v provedl s a vydal certifikát y relevantní z hlediska z:
 A. Další informace o ():
 A.1 Označení
 A.2 Označení
 A.3 Označení
 A.4 Výše uvedený výrobek je v souladu s požadavky směrnice Evropského parlamentu a Rady 2014/34/EU, jedna nebo více uvedených evropských norem již byly nahrazeny novými vydáními. Výrobce prohlašuje, že výrobek je v souladu s těmito novými vydáními, neboť upravené požadavky těchto nových norem nemají na výrobek vliv.

датск (da)
 Overensstemmelseserklæring
 1. Produktmodel / produktnummer / gælder kun for projektnummer:
 2. Fabrikantens (2.1) og dennes bemyndigede repræsentants (2.2) navn og adresse:
 3. Denne overensstemmelseserklæring udstedes på fabrikantens ansvar.
 4. Genstand(ene) for erklæringen:
 5. Genstand(ene) for erklæringen, som beskrevet ovenfor, er i overensstemmelse med den relevante EU-harmoniseringslovgivning.
 6. Referencer til de relevante anvendte harmoniserede standarder eller til de andre tekniske specifikationer, som der erklæres overensstemmelse med.
 7. Det bemyndigede organ har foretaget x og udstedt atesten y, der gælder for z:
 A. Supplerende oplysninger om ()
 A.1 Mærkning
 A.2 Mærkning
 A.3 Mærkning
 A.4 Ovenstående produkt opfylder kravene i direktiv 2014/34/EU. En eller flere af de anførte europæiske standarder er allerede blevet erstattet af nye udgaver. Fabrikanten erklærer, at produktet også er i overensstemmelse med de nye udgaver, idet de ændrede krav i de nye standarder ikke berører produktet.

Deutsch (de)
 Konformitätserklärung
 1. Produktmodell / Produktnummer / gilt ausschließlich für Projekt-Nr.:
 2. Name und Anschrift des Herstellers (2.1) und seines Bevollmächtigten (2.2)
 3. Die alleinige Verantwortung für die Ausstellung dieser Konformitätserklärung trägt der Hersteller.
 4. Gegenstände der Erklärung:
 5. Die oben beschriebenen Gegenstände der Erklärung erfüllen die einschlägigen Harmonisierungsrechtsvorschriften der Union.
 6. Angabe der einschlägigen harmonisierten Normen oder der anderen technischen Spezifikationen, die der Konformitätserklärung zugrunde gelegt wurden:
 7. Die notifizierte Stelle w hat x und die für z relevante Bescheinigung y ausgestellt.
 A. Zusatzangaben zu ():
 A.1 Kennzeichnung
 A.2 Kennzeichnung
 A.3 Kennzeichnung
 A.4 Das oben genannte Produkt erfüllt die Anforderungen der Richtlinie 2014/34/EU. Mindestens eine der aufgeführten europäischen Normen ist bereits durch eine neue Ausgabe ersetzt worden. Der Hersteller erklärt, dass das Produkt mit diesen neuen Ausgaben ebenfalls konform ist, da die geänderten Anforderungen der neuen Normen das Produkt nicht betreffen.

Ελληνικά (el)
 Δήλωση συμμόρφωσης
 1. Μοντέλο προϊόντος / αριθμός προϊόντος / ισχύει μόνο για τον αριθμό του έργου:
 2. Όνομα και διεύθυνση του κατασκευαστή (2.1) και του εξουσιοδοτημένου αναπαραστάτη του (2.2)
 3. Η παρούσα δήλωση συμμόρφωσης εκδίδεται με αποκλειστική ευθύνη του κατασκευαστή.
 4. Στόχος της δήλωσης:
 5. Ο στόχος της δήλωσης που περιγράφεται παραπάνω είναι σύμφωνα με τη σχετική ενωσιακή νομοθεσία ενωμοσύνης.
 6. Παραπομπές στα σχετικά ευρωπαϊκά πρότυπα που χρησιμοποιήθηκαν ή παραπομπές στις κοινές τεχνικές προδιαγραφές σε σχέση με τις οποίες δηλώνεται η συμμόρφωση.
 7. Ο κοινοποιημένος οργανισμός w διεξήγαγε x και εξέδωσε το πιστοποιητικό y όπως απαιτείται για z:
 A. Προσθήκες πληροφοριών σχετικά με ():
 A.1 Σημείωση
 A.2 Σημείωση
 A.3 Σημείωση
 A.4 Το προαναφερθέν προϊόν συμμορφώνεται με τις απαιτήσεις της οδηγίας 2014/34/ΕΕ. Ένα ή περισσότερα από τα αναφερόμενα ευρωπαϊκά πρότυπα έχουν αντικατασταθεί ήδη από νέες εκδόσεις. Ο κατασκευαστής δηλώνει ότι το προϊόν συμμορφώνεται επίσης με τις εν λόγω νέες εκδόσεις, καθώς οι τροποποιημένες απαιτήσεις των νέων προτύπων δεν επηρεάζουν το προϊόν.

español (es)
 Declaración de conformidad
 1. Modelo de producto/número de producto / únicamente válido para el número de proyecto
 2. Nombre y dirección del fabricante (2.1) y de su representante autorizado (2.2)
 3. La presente declaración de conformidad se expide bajo la exclusiva responsabilidad del fabricante.
 4. Objeto(s) de la declaración:
 5. El/Los objeto(s) de la declaración descritos anteriormente son conformes con la legislación de armonización pertinente de la Unión Europea.
 6. Referencias a las normas armonizadas pertinentes utilizadas o referencias a las otras especificaciones técnicas respecto a las cuales se declara la conformidad.
 7. El organismo notificado W ha efectuado X y expedido el certificado Y relevante para Z.
 A. Información adicional en ():
 A.1 Marcado
 A.2 Marcado
 A.3 Marcado
 A.4 El producto mencionado anteriormente cumple con los requisitos de la directiva 2014/34/UE. Una o más de las normas europeas mencionadas ya se han substituído por nuevas ediciones. El fabricante declara que el producto también cumple con estas nuevas ediciones, ya que los requisitos modificados de las nuevas normas no afectan al producto.



EU-Declaration of Conformity



MEU17027

angli kael (en)

Vastavusdeklaratsioon
 1. Tootemudel / tootenumber / heliti) vaid järgmise projekti puhul:
 2. Tootja nimi ja aadress (2.1) ning tema volitatud esindaja (2.2);
 3. Käesolev vastavusdeklaratsioon on välja antud tootja autorisatsioonil;
 4. Deklareeritav toode;
 5. Oluliskõlased deklaratsioonid ja/või muud nõuanded asjaomaste liidu ühustamiskriteeriumide kohta;
 6. Viited kasutatud harmoneeritud standarditele või viited muudele tehnilistele spetsifikatsioonidele, millele vastavus deklaratsiooniks;
 7. Teavitatud asutus ja teostas ja ja andis välja tõendi z, mis on asjakohane y-le;
 A. Lisateave järgmise kohta ():
 A.1 Märkistus
 A.2 Märkistus
 A.3 Märkistus
 A.4 Olulised tooted on kooskõlas direktiivi 2014/34/EÜ nõuetega. Üks või mitu nimetatud Euroopa standardit on asendatud juba uute väljannetega. Tootja kinnitab, et toode on kooskõlas ka nende uute väljannetega, kuna uute standardite muudetud nõuded ei mõjuta toodet.

frantsüsi (fr)

Déclaration de conformité
 1. Modèle / numéro de produit / valable uniquement pour le numéro de projet;
 2. Nom et adresse du fabricant (2.1) et de son mandataire (2.2);
 3. La présente déclaration de conformité est établie sous la seule responsabilité du fabricant;
 4. Objet(s) de la déclaration;
 5. Le ou les objets de la déclaration décrits ci-dessous est (sont) conforme(s) à la législation d'harmonisation de l'Union applicable;
 6. Références des normes harmonisées pertinentes appliquées ou des autres spécifications techniques par rapport auxquelles la conformité est déclarée;
 7. L'organisme notifié w a effectué x et a établi l'attestation y applicable à z;
 A. Informations complémentaires relatives à ():
 A.1 Marquage
 A.2 Marquage
 A.3 Marquage
 A.4 Le produit mentionné est conforme aux exigences de la directive 2014/34/UE. Une ou plusieurs des normes européennes mentionnées ont déjà été remplacées par de nouvelles éditions. Le fabricant déclare que le produit est également conforme à ces nouvelles éditions, dans la mesure où les exigences modifiées des nouvelles normes n'affectent pas le produit.

hollandi (nl)

Uitspraak oorspronkelijk
 1. Model productid / broj proizvođača / važi jedino za broj projekta;
 2. Naziv i adresa proizvođača (2.1) i njegovog ovlaštenog zastupnika (2.2);
 3. Za izdavanje ove izjave o skladnosti odgovoran je isključivo proizvođač;
 4. Predmet(i) izjave;
 5. Predmet(i) navedene izjave po/su u skladu s mjerodavnim zakonodavstvom Unije o usklađivanju;
 6. Pozivaju na relevantne primjenjene usklađene norme ili pozivaju na ostale tehničke specifikacije u vezi s kojima se izjavljuje skladnost;
 7. Povoljeno tijelo w provelo je x i izdalo certifikat y koji je relevantan za z;
 A. Dodatne informacije o proizvodu ():
 A.1 Označavanje
 A.2 Označavanje
 A.3 Označavanje
 A.4 Prethodno navedeni proizvod u skladu je sa zahtjevima Direktive 2014/34/EU. Jedna ili više navedenih europskih normi već je zamijenjeno novim izdanjima. Proizvođač izjavljuje da je proizvod u skladu i s tim novim izdanjima, jer se izmijenjeni zahtjevi ili novih normi ne odnose na proizvod.

magyar (hu)

Megfelelőségi nyilatkozat
 1. Termékmodell / termékszám / kizárólag az alábbi projektszámmal, érvényes;
 2. A gyártó (2.1) vagy adott esetben meghatalmazott képviselőjének (2.2) neve és címe;
 3. Ezt a megfelelőségi nyilatkozatot a gyártó kizárólagos felelőssége mellett adja ki;
 4. A nyilatkozat tárgya(i);
 5. A fent ismertetett nyilatkozat tárgya megfelel a vonatkozó uniós harmonizációs jogszabályoknak;
 6. Az alkalmazott harmonizált szabványokra való hivatkozás vagy az azokra az egyéb műszaki leírásokra való hivatkozás, amelyekkel kapcsolatban megfelelőségi nyilatkozatot tettek;
 7. A(z) w bejelentett szervezet elvégezte a(z) x eljárást, és kiállította a(z) y kapcsolódó y tanúsítványt;
 A. További információk ():
 A.1 Jelölés
 A.2 Jelölés
 A.3 Jelölés
 A.4 A fentebb megnevezett termék megfelel a 2014/34/EU irányelvben foglalt követelményeknek. Egy vagy több említett európai szabvány a kiállítás óta frissült. A gyártó kijelenti, hogy a termék megfelel a szabványok legújabb kiadásában foglalt követelményeknek, mivel a szabvány módosításai nem érintik az adott terméket.

italiano (it)

Dichiarazione di conformità
 1. Modello di prodotto / numero di prodotto / valido unicamente per numero di progetto;
 2. Nome e indirizzo del fabbricante (2.1) e del relativo rappresentante autorizzato (2.2);
 3. La presente dichiarazione di conformità è rilasciata sotto la responsabilità esclusiva del fabbricante;
 4. Oggetto/i della dichiarazione;
 5. L'oggetto o gli oggetti della dichiarazione di cui sopra sono conformi alla pertinente normativa di armonizzazione dell'Unione;
 6. Riferimento alle pertinenti norme armonizzate utilizzate o riferimenti alle altre specifiche tecniche in relazione alle quali è dichiarata la conformità;
 7. L'organismo notificato w ha effettuato x e rilasciato il certificato y pertinente a z;
 A. Informazioni aggiuntive su ():
 A.1 Marcatura
 A.2 Marcatura
 A.3 Marcatura
 A.4 Il prodotto menzionato in precedenza è conforme alle prescrizioni della direttiva 2014/34/UE. Una o più norme UE menzionate sono già state sostituite da nuove versioni. Il fabbricante dichiara che il prodotto è conforme anche alle nuove versioni in quanto le prescrizioni modificate delle nuove norme non interessano il prodotto.

Litván kalba (lt)

Atitikties deklaracija
 1. Gaminiio modelis / gaminiio numeris / galioja tik projekto numerui;
 2. Gamintojo (2.1) ir jo įgaliotojo asmens (2.2) pavadinimas ir adresas;
 3. Ši atitikties deklaracija išdota tik gamintojo atsakomybe;
 4. Deklaracijos objektas (objektai);
 5. Pirminis apyvartos deklaracijos objektas (objektai) atitinka susijusius deramumo su Sąjunga teisės aktus;
 6. Susijusių taikytų darnųjų standartų nuorodos arba kitų techninių specifikacijų, pagal kurias buvo deklaruota atitiktis, nuorodos;
 7. Notifikuoti įstaiga w atliko x ir išdavė sertifikata y dėl z:
 A. Papildoma informacija ():
 A.1 Ženklinimas
 A.2 Ženklinimas
 A.3 Ženklinimas
 A.4 Pirminis nuorodytas gaminytis atitinka Direktyvos 2014/34/ES reikalavimus. Vienas ar keli nuorodyti Europos standartai jau pakeisti nauja redakcija. Gamintojas patvirtina, kad gaminytis (tarp pat atitinka naująją redakciją, nes pakeisti naujųjų standartų reikalavimai gaminiui poveikio neturi.



EU-Declaration of Conformity



MEU17027

latvian (lv)
 Atbilstības deklarācija
 1. Produkta modeļa / produkta numurs / derīgā šķirne projekta Nr.:
 2. Ražotāja (2.1.) un tā pilnvarotā pārstāvja (2.2.) nosaukums un adrese:
 3. Šī atbilstības deklarācija ir izdota vienīgi uz ražotāja atbildību
 4. Deklarācijas priekšmets vai priekšmeti:
 5. Iepriekš izstrādātās deklarācijas priekšmets vai priekšmeti atbilst attiecīgajam Savienības noteikumu akta numuram
 6. Atsauces uz attiecīgajiem izstrādājumiem saskaņotajiem standartiem vai uz citām tehniskajām specifikācijām, attiecībā uz ko tiek deklarēta atbilstība:
 7. Paziņotā struktūra w ir veikusi x un izsniegusi sertifikātu y, kas attiecas uz z:
 A. Papildu informācija par ():
 A.1 Marķējums
 A.2 Marķējums
 A.3 Marķējums
 A.4. Iepriekš minētās produkta atbilst Direktīvas 2014/34/ES prasībām. Viens vai vairāki no minētajiem Eiropas standartiem jauti ir atzīmēti ar jaunām versijām. Ražotājs apliecinā, ka produkts atbilst arī šīm jaunajām versijām, jo jāmāo saskaņotā minētās prasības noteiktām produktā.

italian (it)
 Dichiarazione di conformità
 1. Modello (tal-prodott / numru tal-prodott / valida bass għan-numri tal-prodott):
 2. L-ismen u l-indirizz tal-manifattur (2.1) u tar-rappreżentanti awtorizzati tiegħa (2.2):
 3. Din id-dikjarazzjoni ta' konformità tindareg tal-ir-responsabbiltà unika tal-manifattur
 4. L-għan(jiet) tad-dikjarazzjoni:
 5. L-għan(jiet) tad-dikjarazzjoni deskritt(i) hawn fuq huwa(huma) konformi mal-legislazzjoni ta' armonizzazzjoni rilevanti tal-Unjoni:
 6. Ir-referenzi għall-istandards armonizzati rilevanti li nuzaw, jw u r-referenzi għall-ispeċifikazzjonijiet tekniċi l-oħra li s-konformi qad tigi ddikjarata l-konformità:
 7. Il-korp notifikat w wettaq x u hareg id-certifikat u rilevanti għal z:
 A. Informazzjoni addizzjonali f'haq ():
 A.1 Immarkar
 A.2 Immarkar
 A.3 Immarkar
 A.4 Il-prodott msemmi hawn fuq huwa l-konformità mar-rekwiżiti tad-Direttiva 2014/34/UE. Wieheh jsew skur null-istandards Ewropej imsemmija digi jsew sostitwiti b'edizzjonijiet godda bass. Il-manifattur jidkljarja li l-prodott huwa konformi wkoll ma' dawn l-edizzjonijiet godda, għax ir-rekwiżiti tal-istandards il-godda ma jaffettwawx il-prodott

dutch (nl)
 Conformiteitsverklaring
 1. Productmodel / productnummer / uitsluitend geldig voor projectnummer:
 2. Naam en adres van de fabrikant (2.1) en zijn gemachtigde (2.2):
 3. Deze conformiteitsverklaring wordt verstrekt onder volledige verantwoordelijkheid van de fabrikant.
 4. Voorwerpen van de verklaring:
 5. Het (de) hierboven beschreven voorwerpen (is (zijn)) in overeenstemming met de desbetreffende harmonisatiewetgeving van de Unie.
 6. Vermelding van de toegepaste relevante geharmoniseerde normen of van de overige technische specificaties waarop de conformiteitsverklaring betrekking heeft.
 7. De aangemelde instantie w heeft een x uitgevoerd en het certificaat w verstrekt dat relevant is voor z:
 A. Aanvullende informatie over ():
 A.1 Markering
 A.2 Markering
 A.3 Markering
 A.4 Het bovengenoemde product voldoet aan de eisen van Richtlijn 2014/34/EU. Een of meer van de genoemde Europese normen zijn inmiddels vervangen door nieuwe versies. De fabrikant verklaart dat het product ook aan deze nieuwe versies voldoet, aangezien de gewijzigde eisen van de nieuwe normen geen gevolgen hebben voor het product

polish (pl)
 Deklaracja zgodności
 1. Model produktu / numer produktu / ważny wyłącznie dla projektu o numerze:
 2. Nazwa i adres producenta (2.1) oraz jego upoważnionego przedstawiciela (2.2).
 3. Niniejsza deklaracja zgodności wydana zostaje na wyłączną odpowiedzialność producenta.
 4. Przedmiot(-y) deklaracji:
 5. Wymieniony powyżej przedmiot (lub przedmioty) niniejszej deklaracji jest zgodny z odnośnymi wymaganiami unijnego prawodawstwa harmonizacyjnego:
 6. Odwołania do odnośnych norm zharmonizowanych, które zastosowano, lub do innych specyfikacji technicznych, w stosunku do których deklarowana jest zgodność:
 7. Jednostka notyfikowana w przeprowadziła x i wydała certyfikat y odpowiedni dla z:
 A. Informacje dodatkowe o ():
 A.1 Czynakowanie
 A.2 Czynakowanie
 A.3 Czynakowanie
 A.4 Wyżej wymieniony produkt jest zgodny z wymaganiami Dyrektywy 2014/34/UE.
 Co najmniej jedna wymieniona norma europejska została już zastąpiona nowymi wydaniami. Producent oświadcza, że produkt spełnia wymagania także takich nowych wydań norm, gdyż zmienione wymagania zawarte w nowych normach nie mają wpływu na produkt.

portuguese (pt)
 Declaração de conformidade
 1. Modelo do produto / número do produto / somente válido para o número do projeto:
 2. Nome e endereço do fabricante (2.1) e do seu mandatário (2.2).
 3. A presente declaração de conformidade é emitida sob a exclusiva responsabilidade do fabricante.
 4. Objeto(s) da declaração:
 5. O(s) objeto(s) da declaração acima descrito(s) estão em conformidade com a legislação aplicável de harmonização da União:
 6. Referências às normas harmonizadas aplicáveis utilizadas ou às outras especificações técnicas em relação às quais é declarada a conformidade:
 7. O organismo notificado w realizou x e emitiu o certificado y relevante para z:
 A. Informações complementares relativa a ():
 A.1 Marcação
 A.2 Marcação
 A.3 Marcação
 A.4 O produto acima mencionado está em consonância com os requisitos da diretiva 2014/34/UE. Uma ou mais das Normas Europeias mencionadas acima já foram substituídas por novas edições. O fabricante declara que o produto também está em conformidade com essas novas edições, uma vez que os requisitos alterados dessas novas Normas não afetam o produto.

romanian (ro)
 Declarație de conformitate
 1. Modelul de produs / Număr produs / valabil numai pentru numărul proiectului:
 2. Denumirea și adresa producătorului (2.1) și a reprezentantului său autorizat (2.2).
 3. Prezenta declarație de conformitate este emisă pe răspunderea exclusivă a producătorului.
 4. Obiectul (obiectele) declarației:
 5. Obiectul (obiectele) declarației descrise mai sus sunt în conformitate cu legislația relevantă de armonizare a Uniunii:
 6. Trimiten la standardele armonizate relevante folosite sau trimiten la celelalte specificații tehnice în legătură cu care se declară conformitatea:
 7. Organismul notificat w a efectuat x și a emis certificatul y corespunzător pentru z:
 A. Informații suplimentare despre ():
 A.1 Marcă
 A.2 Marcă
 A.3 Marcă
 A.4 Produsul menționat anterior respectă cerințele directivei 2014/34/UE. Unul sau mai multe din standardele europene menționate sunt deja înlocuite de noi ediții. Producătorul declară faptul că produsul respectă de asemenea aceste noi ediții, ășadar cerințele modificate ale noilor standarde nu afectează produsul.



EU-Declaration of Conformity

MEU17027



šlověnčina (sl)

Vyhlašenje o zhlode
 1. Model výroba / číslo výroba / plátné lan pre číslo projekta.
 2. Méno/názov a adresa výroba (2.1) a jeho právomocného zástupca (2.2).
 3. Toto vyhlášení o zhlode sa vydáva na vlastnú zodpovednosť výroba.
 4. Predmet(-y) vyhlášení.
 5. Uvedený predmet či uvedené predmety vyhlášení sú v zhode s príslušnými harmonizačnými právnymi predpismi Únie.
 6. Odľazy na príslušné použité harmonizované normy alebo odkazy na tie technické špecifikácie, v súvislosti s ktorými sa zhloda vyhlášení.
 7. Notifikovaný orgán w vykonal x a vydal certifikát y relevantný pre z:
 A.1 Označenie
 A.2 Označenie
 A.3 Označenie
 A.4 Vyššie uvedený výrobok je v súlade s požiadavkami smernice 2014/34/EU. Jedna alebo viaceré z uvedených európskych noriem sú už nahradené novými vydávaniami. Výrobok vyhlášení. Je výrobok je v zhode aj s týmito novými vydávaniami, pretože zmena požiadavkových noriem nemá na výrobok vplyv.

šlověnčina (sl)

Izjava o skladnosti
 1. Model proizvoda / serijska številka proizvoda / veljavno samo za številko projekta.
 2. Ime in naslov proizvajalca (2.1) ter njegovega pooblaščenega zastopnika (2.2).
 3. Za izdajo te izjave v skladnosti je odgovoren izključno proizvajalec.
 4. Predmet(i) izjave:
 5. Predmet(i) navedene izjave je (so) v skladu z ustrežno zakonodajo Unije o harmonizaciji.
 6. Sklicevanja na uporabljene ustrežne harmonizirane standarde ali sklicevanja na druge tehnične specifikacije v zvezi s skladnostjo, ki je navedena v izjavi.
 7. Priglaseni organ w je izvedel x in izdal certifikat y, pomenben za z:
 A.1 Označba
 A.2 Označba
 A.3 Označba
 A.4 Zgornji navedeni proizvod je v skladu z zahtevami direktive 2014/34/EU. Enega ali več omenjenih evropskih standardov so že nadomestile nove izdaje. Proizvajalec izjavlja, da je proizvod skladen s temi novimi izdajami, saj spremenjena zahteva novih standardov ne vplivajo na proizvod.

mónni (fi)

Vaatimustenmukaisuusvakuutus
 1. Tuotennimi / tuotenumero / koskeen vain projektinumero.
 2. Valmistajan (2.1) ja valtuutetun edustajan (2.2) nimi ja osoite.
 3. Tämä vaatimustenmukaisuusvakuutus on annettu valmistajan yksinomaista vastuulla.
 4. Vakuutuksen kohde (kohdet):
 5. Edellä kuvattu (kuvatut) vakuutuksen kohde (kohdet) on (ovat) asiaa koskevan unionin yhdenmukaistamissääntöjen vaatimusten mukainen (mukaisia).
 6. Viittaus niihin asiaa koskeviin yhdenmukaistettuihin standardeihin, joita on käytetty, tai viittaus muihin teknisiin eritelmiin, joiden perusteella vaatimustenmukaisuusvakuutus on annettu.
 7. Ilmoitettu laitos w suoritti x ja antoi todistuksen y liittyen z:
 A.1 Lisätietoja ():
 A.1 Merkintä
 A.2 Merkintä
 A.3 Merkintä
 A.4 Yllä mainittu tuote vastaa direktiivin 2014/34/EU vaatimuksia. Yksi tai useampi mainittuista eurooppalaisista standardeista on jo korvattu uusilla painoksilla. Valmistaja vakuuttaa, että tuote vastaa myös niitä uusia painoksia, koska uusien standardien muutokset määrityksi eivät vaikuta tuotteeseen.

svenska (sv)

Försäkran om överensstämmelse
 1. Produktmodell / produktnummer / gäller endast för projektnummer.
 2. Tillverkarens namn och adress (2.1) och dess auktoriserade representant (2.2).
 3. Denna försäkran om överensstämmelse utdödas på tillverkarens eget ansvar.
 4. Föremålet för försäkran.
 5. Föremålet/föremålen för försäkran öyut överensstämmer med den relevanta harmoniserade unionslagstiftningen.
 6. Hänvisningar till de relevanta harmoniserade standarder som antäts eller hänvisningar till de andra tekniska specifikationer enligt vilka överensstämmelsen försäkras.
 7. Det nämnda organet w har utfört x och utfärdat intyget y relevant för z:
 A. Ytterligare information om ():
 A.1 Märkning
 A.2 Märkning
 A.3 Märkning
 A.4 Övan nämnda produkt är i linje med kraven i direktiv 2014/34/EU. En eller flera av de nämnda europeiska standarderna har redan ersatts av nya upplagor. Tillverkaren försäkrar att produkten även överensstämmer med dessa nya upplagor, då de antralde kraven i de nya standarderna inte påverkar produkten.

12.10 RU Д-DE.A301.B.05345

	ЕВРАЗИЙСКИЙ ЭКОНОМИЧЕСКИЙ СОЮЗ ДЕКЛАРАЦИЯ О СООТВЕТСТВИИ
<p>Заявитель Общество с ограниченной ответственностью «ДС Компания». Основной государственный регистрационный номер: 1107746937374. Место нахождения: 105037, Российская Федерация, город Москва, улица 3-я Парковая, дом 9, квартира 18 Телефон: 89660273663, адрес электронной почты: dc.company2000@gmail.com в лице Генерального директора Ежова Олега Олеговича</p>	
<p>заявляет, что Генераторы типов: PR6201, PR6202, PR6211, PR6212, PR6251, PR6221, PR6261, PR6224, PR6204, PR6246, PR6241, PR6207 Продукция изготовлена в соответствии с Директивой 2014/30/ЕС «Электромагнитная совместимость» изготовитель Minebea Intec GmbH. Место нахождения: ГЕРМАНИЯ, Meiendorfer Strasse 205, 22145 Hamburg</p>	
<p>код ТН ВЭД ЕАЭС 9031 80 380 0</p>	
<p>Серийный выпуск соответствует требованиям Технического регламента Таможенного союза ТР ТС 020/2011 "Электромагнитная совместимость технических средств"</p>	
<p>Декларация о соответствии принята на основании протокола испытаний № 314-04/12-СТ от 13.04.2017 года, выданного испытательной лабораторией «Серт-Тест» Общества с ограниченной ответственностью «Серт и Ко», регистрационный № РОСС RU.04ИДЮ0.002: руководства по эксплуатации; паспорта</p>	
<p>Схема декларирования: Id</p>	
<p>Дополнительная информация Условия хранения продукции в соответствии с требованиями ГОСТ 15150-69. Срок хранения (службы, годности) указан в прилагаемой к продукции эксплуатационной документации. Стандарты, обеспечивающие соблюдение требований Технического регламента Таможенного союза ТР ТС 020/2011 "Электромагнитная совместимость технических средств": ГОСТ 30804.3.2-2013 "Совместимость технических средств электромагнитная. Эмиссия гармонических составляющих тока техническими средствами с потребляемым током не более 16 А (в одной фазе). Нормы и методы испытаний", ГОСТ 30804.3.3-2013 "Совместимость технических средств электромагнитная. Ограничение изменений напряжения, колебаний напряжения и фликера в низковольтных системах электроснабжения общего назначения. Технические средства с потребляемым током не более 16 А (в одной фазе), подключаемые к электрической сети при несоблюдении определенных условий подключения. Нормы и методы испытаний"</p>	
<p>Декларация о соответствии действительна с даты регистрации по 12.04.2022 включительно.</p>	
	<p>Ежов Олег Олегович <small>(подпись и печать уполномоченного представителя лиц, зарегистрированных в качестве индивидуальных предпринимателей)</small></p>
<p>Сведения о регистрации декларации о соответствии: Регистрационный номер декларации о соответствии: ЕАЭС № RU Д-DE.A301.B.05345 Дата регистрации декларации о соответствии 13.04.2017</p>	

12.11 RU C-DE.MЮ62.B.05836

ТАМОЖЕННЫЙ СОЮЗ

СЕРТИФИКАТ СООТВЕТСТВИЯ

№ ТС RU C-DE.MЮ62.B.05836

Серия RU № **0589458**

ОРГАН ПО СЕРТИФИКАЦИИ продукция Общество с ограниченной ответственностью «ПРОММАШ ТЕСТ».
 Место нахождения: 117246, город Москва, Научный проезд, дом 8, строение 1, помещение XIX, комната №14-17.
 Адрес места осуществления деятельности: 115114, Российская Федерация, город Москва, Дербеневская набережная, дом 11, помещение 60. Телефон: +7 (495) 481-33-80, адрес электронной почты: info@prommashtest.ru. Аттестат аккредитации регистрационный № РОСС RU.0001.11MЮ62. Дата регистрации аттестата аккредитации 28.10.2013 года

ЗАЯВИТЕЛЬ Общество с ограниченной ответственностью «ДС Компания».
 Основной государственный регистрационный номер: 1107746937374.
 Место нахождения: 105037, Российская Федерация, город Москва, улица 3-я Парковая, дом 9, офис 18
 Телефон: 89295245611, адрес электронной почты: dc.company2000@gmail.com

ИЗГОТОВИТЕЛЬ Minebea Intec GmbH.
 Место нахождения: ГЕРМАНИЯ, Meindorfer Strasse 205 A, 22145 Hamburg

ПРОДУКЦИЯ Датчики нагрузки моделей PR 6201, PR 6212, PR 6261.
 Маркировка взрывозащиты приведена в приложении (бланки №№ 0472416, 0472417).
 Оборудование выпускается по Директиве 2014/34/ЕС и технической документации изготовителя для работы во взрывоопасных средах.
 Серийный выпуск

КОД ТН ВЭД ТС 9031 80 980 0

СООТВЕТСТВУЕТ ТРЕБОВАНИЯМ Технического регламента Таможенного союза ТР ТС 012/2011
 "О безопасности оборудования для работы во взрывоопасных средах"

СЕРТИФИКАТ ВЫДАН НА ОСНОВАНИИ
 - акта о результатах анализа состояния производства Minebea Intec GmbH от 12.02.2018 года;
 - протокола испытаний № 2024/ЗИЛПМ-2018 от 26.02.2018 года. Испытательный центр Общество с ограниченной ответственностью «ПРОММАШ ТЕСТ», аттестат аккредитации регистрационный № RA.RU.21BC05 действителен от 26.04.2016 года.

Схема сертификации: 1с



ДОПОЛНИТЕЛЬНАЯ ИНФОРМАЦИЯ
 Срок службы, срок и условия хранения указаны в руководстве по эксплуатации.
 Стандарты, обеспечивающие соблюдение требований Технического регламента Таможенного союза ТР ТС 012/2011
 "О безопасности оборудования для работы во взрывоопасных средах": согласно приложению (бланки №№ 0472416, 0472417).



СРОК ДЕЙСТВИЯ С 27.02.2018 **ПО** 26.02.2023 **ВКЛЮЧИТЕЛЬНО**

<p>Руководитель (уполномоченное лицо) органа по сертификации</p> <p>Эксперт (эксперт-аудитор) (эксперты (эксперты-аудиторы))</p>	<p>Иван Викторович Модянов (инициалы, фамилия)</p> <p>Анатолий Владимирович Ивочкин (инициалы, фамилия)</p>
--	---



Бланк изготовлен ЗАО "ОПЦИОН" · www.opcion.ru (лицензия № 05-05-09703 ФНС РФ) · тел. (495) 726 4742, Москва, 2013

ТАМОЖЕННЫЙ СОЮЗ			
ПРИЛОЖЕНИЕ			
К СЕРТИФИКАТУ СООТВЕТСТВИЯ № ТС	RU C-DE.MIO62.B.05836		
Серия RU	№ 0472416		
1. Назначение и область применения			
Сертификат соответствия распространяется на датчики нагрузки моделей PR 6201, PR 6212, PR 6261, предназначенные для взвешивания бункеров, резервуаров и технологических емкостей.			
Область применения - взрывоопасные зоны классов 0, 1, 2 по ГОСТ IEC 60079-10-1-2011 категорий взрывоопасных смесей IIA, IIB, IIC по ГОСТ Р МЭК 60079-20-1-2011, а также среды, содержащие взрывоопасную пыль подгрупп IIA, IIB, IIC согласно маркировкам взрывозащиты.			
2. Описание оборудования и средств обеспечения взрывозащиты			
Датчики нагрузки моделей PR 6201, PR 6212, PR 6261 выполнены в цилиндрическом стальном корпусе со степенью защиты от внешних воздействий IP68 или IP69 в зависимости от исполнения. Устройства содержат мембрану и тензодатчик сопротивления, преобразующие механическую деформацию, возникающую при нагрузке датчика, в электрический сигнал.			
Подключение датчиков осуществляется с помощью постоянно присоединенного кабеля из термопласта TPE.			
Подробное описание конструкции датчиков приведено в руководствах по эксплуатации.			
Основные технические данные:			
Маркировка взрывозащиты.....	0Ex ia IIC T6 2Ex nA IIC T6 X Ex tc IIIC T85°C X Ex ta IIIC T160°C X		
Диапазон температур окружающей среды, °C.....	от -52 до +55		
Степень защиты от внешних воздействий по ГОСТ 14254-2015.....	IP68, IP69		
Максимальное напряжение питания, В.....	25		
Максимальная входная мощность, Вт.....	2		
Параметры искробезопасных цепей приведены в таблице 2.1:			
Таблица 2.1			
Наименование	Значение		
Максимальное входное напряжение U_i , В	25		
Максимальный входной ток I_i , mA	160		
Максимальная входная мощность P_i , Вт	2		
Максимальная внутренняя емкость C_i , мкФ	0		
Максимальная внутренняя индуктивность L_i , мГн	0		
Взрывозащищенность датчиков обеспечивается выполнением их конструкции в соответствии с общими требованиями по ГОСТ 31610.0-2012, видом взрывозащиты «искробезопасная электрическая цепь «i» по ГОСТ 31610.11-2012, видом защиты «n» по ГОСТ 31610.15-2012 и видом взрывозащиты от воспламенения пыли «t» по ГОСТ Р МЭК 60079-31-2010.			
Внесение изготовителем в конструкцию и техническую документацию изменений, влияющих на взрывобезопасность и соответствие газоанализаторов требованиям ТР ТС 012/2011, возможно только по согласованию с органом по сертификации ООО «ПРОММАШ ТЕСТ».			
Данный сертификат соответствия подтверждает соответствие требованиям взрывобезопасности ТР ТС 012/2011 и не рассматривает любые другие виды безопасности газоанализаторов.			
	Руководитель (уполномоченное лицо) органа по сертификации	 подпись	Иван Викторович Модянов инициалы, фамилия
	Эксперт-аудитор (эксперт)	 подпись	Анатолий Владимирович Ивочкин инициалы, фамилия
АО «ОПЦИОН», Москва, 2016, «Б» лицензия № 05-05-09/003 ФНС РФ, тел. (495) 726 4742, www.opcion.ru			

ТАМОЖЕННЫЙ СОЮЗ			
ПРИЛОЖЕНИЕ			
К СЕРТИФИКАТУ СООТВЕТСТВИЯ № ТС	RU C-DE.MIO62.B.05836		
	Серия RU № 0472417		
3. Оборудование соответствует требованиям:			
ТР ТС 012/2011	Технический регламент Таможенного союза «О безопасности оборудования для работы во взрывоопасных средах»;		
ГОСТ 31610.0-2012	Электрооборудование для взрывоопасных газовых сред. Часть 0. Общие требования;		
ГОСТ 31610.11-2012	Электрооборудование для взрывоопасных газовых сред. Часть 11. Искробезопасная электрическая цепь «i»;		
ГОСТ 31610.15-2012	Электрооборудование для взрывоопасных газовых сред. Часть 15. Конструкция, испытания и маркировка электрооборудования с видом защиты «п»;		
ГОСТ Р МЭК 60079-31-2010	Взрывоопасные среды. Часть 31. Оборудование с видом взрывозащиты от воспламенения пыли «т».		
4. Маркировка			
Маркировка, наносимая на электрооборудование, должна включать следующие данные:			
4.1	наименование предприятия-изготовителя или его зарегистрированный товарный знак;		
4.2	обозначение типа оборудования;		
4.3	порядковый номер по системе нумерации предприятия-изготовителя;		
4.4	маркировку взрывозащиты см. п. 2 «Основные технические данные»;		
4.5	наименование или знак органа по сертификации и номер сертификата соответствия;		
4.6	предупредительные надписи;		
4.7	единый знак ЕАС обращения продукции на рынке государств - членов Таможенного союза;		
4.8	специальный знак взрывобезопасности Ex в соответствии с ТР ТС 012/2011;		
4.9	Другие данные, которые должен отразить изготовитель, если это требуется технической документацией (диапазон температур окружающей среды, степень защиты оболочки и т.д.).		
5. Специальные условия применения			
Знак X, стоящий после Ex-маркировки, означает, что при эксплуатации необходимо соблюдать следующие специальные условия:			
- для подключения гибкого вывода датчиков во взрывоопасной зоне должны применяться сертифицированные взрывозащищенные коробки;			
- электрические параметры питания датчиков не должны превышать значений, приведенных в разделе 2;			
- для оборудования предназначенного для установки во взрывоопасные пылевые зоны необходимо применять меры, препятствующие накоплению электростатического заряда.			
	Руководитель (уполномоченное лицо) органа по сертификации Эксперт-аудитор (эксперт)	 <small>подпись</small>	Иван Викторович Модянов <small>инициалы, фамилия</small>
		 <small>подпись</small>	Анатолий Владимирович Ивочкин <small>инициалы, фамилия</small>
АО «ОПЦИОН», Москва, 2016, «Б» лицензия № 05-05-09/003 ФНС РФ • тел. (495) 126 4742, www.option.ru			

12.12 DE.C.28.541.A No. 68244

ФЕДЕРАЛЬНОЕ АГЕНТСТВО
ПО ТЕХНИЧЕСКОМУ РЕГУЛИРОВАНИЮ И МЕТРОЛОГИИ

СВИДЕТЕЛЬСТВО

об утверждении типа средств измерений

DE.C.28.541.A № 68244

Срок действия до 04 декабря 2022 г.

НАИМЕНОВАНИЕ ТИПА СРЕДСТВ ИЗМЕРЕНИЙ
Датчики весоизмерительные PR 6201, PR 6212

ИЗГОТОВИТЕЛЬ
Фирма "Minebea Intec GmbH", Германия

РЕГИСТРАЦИОННЫЙ № 69603-17

ДОКУМЕНТ НА ПОВЕРКУ
Приложение ДА "Методика поверки" ГОСТ 8.631-2013

ИНТЕРВАЛ МЕЖДУ ПОВЕРКАМИ 1 год

Тип средств измерений утвержден приказом Федерального агентства по техническому регулированию и метрологии от 04 декабря 2017 г. № 2695

Описание типа средств измерений является обязательным приложением к настоящему свидетельству.

Заместитель Руководителя
Федерального агентства

С.С.Голубев

"14" 2017 г.

Серия СИ

№ 039773

Приложение к свидетельству № **68244**
об утверждении типа средств измерений

Лист № 1
Всего листов 5

ОПИСАНИЕ ТИПА СРЕДСТВА ИЗМЕРЕНИЙ

Датчики весоизмерительные PR 6201, PR 6212

Назначение средства измерений

Датчики весоизмерительные PR 6201, PR 6212 (далее - датчики) предназначены для измерений и преобразования воздействующей на датчик силы тяжести взвешиваемого объекта в аналоговый нормированный электрический измерительный сигнал.

Описание средства измерений

Принцип действия датчиков основан на изменении электрического сопротивления тензорезисторов, соединенных в мостовую схему, при их деформации, возникающей в местах наклейки тензорезисторов к упругому элементу датчика, под действием прилагаемой нагрузки. Изменение электрического сопротивления вызывает разбаланс мостовой схемы и появление в диагонали моста электрического сигнала, изменяющегося пропорционально нагрузке.

Датчики состоят из упругого элемента, кабеля питания и измерения, тензорезисторов на клеевой основе, соединенных по полной мостовой электрической схеме, и элементов герметизации. Места наклейки тензорезисторов и расположения элементов термокомпенсации и нормирования в датчиках находятся во внутренней полости упругого элемента и защищены крышками и герметиком.

Модификации датчиков отличаются максимальной нагрузкой, максимальным числом поверочных интервалов.



Рисунок 1 - Внешний вид датчика весоизмерительного PR6201

Лист № 2
Всего листов 5



Рисунок 2 - Внешний вид датчика весоизмерительного PR6212



Рисунок 2 - Маркировочная табличка датчиков весоизмерительных PR 6201, PR 6212

Пломбирование датчиков весоизмерительных PR 6201, PR 6212 не предусмотрено.

Программное обеспечение
отсутствует.

Метрологические и технические характеристики

Таблица 1 - Метрологические характеристики

Модификация PR 6201					
Наименование характеристики	Значение				
Класс точности по ГОСТ 8.631-2013	D1	C3	C4	C5	C6
Максимальное число поверочных интервалов, $n_{max} = E_{max} / v$	1000	3000	4000	5000	6000
Максимальная нагрузка, E_{max} , т	0,5; 1; 2; 3; 5; 10; 20; 30; 50; 60; 75	2, 3, 5, 10, 20, 30, 50, 60, 75	20, 30, 50, 60, 75	20, 30, 50, 60, 75	20, 30

Модификация PR 6201				
Наименование характеристики	Значение			
Минимальная нагрузка, E_{min} , т	0			
Минимальный поверочный интервал, v_{min} , кг	E_{max} /1750 для $E_{max}=0,5$ т; E_{max} /3500 для $E_{max}=1$ т; E_{max} /5000 для $E_{max}=2, 3, 5, 10, 20, 30, 50, 60, 75$ т	E_{max} /7000 для $E_{max}=2$ т; E_{max} /9000 для $E_{max}=3$ т; E_{max} /14000 для $E_{max}=5, 10, 20, 30, 50, 60, 75$ т	E_{max} /20000	
Доля от пределов допускаемой погрешности весов, p_{LC}	0,7			
Значение поверочного интервала v , кг	E_{max}/n_{max}			
Невозврат выходного сигнала при возврате к минимальной нагрузке DR, выраженный через поверочный интервал v	E_{max} /2000 для $E_{max}=0,5$ т	E_{max} /6000 для $E_{max}=2, 3, 5, 10$ т; E_{max} /12000 для $E_{max}=20, 30, 50, 60, 75$ т	E_{max} /16000 для $E_{max}=20, 30$ т; E_{max} /12000 для $E_{max}=50, 60, 75$ т	E_{max} /16000
Номинальный выходной сигнал, мВ/В	1,0 для $E_{max}=0,5, 1; 2; 3; 5; 10, 20, 30$ т; 2,0 для $E_{max}=50$ т; 2,4 для $E_{max}=60$ т; 3,0 для $E_{max}=75$ т	1,0 для $E_{max}=2, 3, 5, 10, 20, 30$ т; 2,0 для $E_{max}=50$ т; 2,4 для $E_{max}=60$ т; 3,0 для $E_{max}=75$ т		
Значение входного сопротивления датчиков, Ом	650 ±6			
Значение выходного сопротивления датчиков, Ом	610 ±1	610 ±0,5		
Предельные значения температуры, °С	от - 10 до + 55			
Обозначение по влажности	СН			

Таблица 2 - Метрологические характеристики

Модификация PR 6212		
Наименование характеристики	Значение	
Класс точности по ГОСТ 8.631-2013	С	
Максимальное число поверочных интервалов, $n_{max} = E_{max} / v$	2000	1000
Максимальная нагрузка, E_{max} , т	0,5; 1; 2	0,5; 1; 2; 3; 5; 10
Минимальная нагрузка, E_{min} , т	0	
Минимальный поверочный интервал, v_{min} , кг	E_{max} /8000	E_{max} /5000
Доля от пределов допускаемой погрешности весов, p_{LC}	0,7	
Значение поверочного интервала v , кг	E_{max}/n_{max}	

Лист № 4
Всего листов 5

Модификация PR 6212		
Наименование характеристики	Значение	
Невозврат выходного сигнала при возврате к минимальной нагрузке DR, выраженный через поверочный интервал ν	$E_{\max}/4000$	$E_{\max}/3000$
Номинальный выходной сигнал, мВ/В	2,0	
Значение входного сопротивления датчиков, Ом	650±6	
Значение выходного сопротивления датчиков, Ом	610±1	
Предельные значения температуры, °С	от - 10 до + 40	
Обозначение по влажности	СН	

Таблица 3 - Основные технические характеристики

Наименование характеристики	Значение	
	Модификация	
	PR 6201	PR 6212
Габаритные размеры средства измерений, мм, не более		
- высота	138,5	46,6
- диаметр	90	67,2
Масса, кг, не более	5,5	1,4
Напряжение питания, В	От 4 до 24	
Средний срок службы, лет	10	
Вероятность безотказной работы за 2000 ч	0,9	

Таблица 4 - Пределы допускаемых погрешностей датчиков различных модификаций

Интервалы измерений	Пределы допускаемой погрешности mpe
до 500v включ.	±0,35v
св. 500v до 2000v включ.	±0,70v
св. 2000v	±1,05v

Знак утверждения типа

наносится типографским способом на титульный лист паспорта и на маркировочную табличку на корпусе датчика.

Комплектность средства измерений

Таблица 5 - Комплектность средства измерений

Наименование	Обозначение	Количество
Датчик весоизмерительный	PR 6201 или PR6212	1 шт.
Паспорт	-	1 экз.

Проверка

осуществляется в соответствии с приложением ДА «Методика поверки» ГОСТ 8.631-2013.

Основные средства поверки:

для датчиков с числом поверочных интервалов $n_{LC} \leq 3000$ рабочие эталоны 1-го разряда по ГОСТ 8.640-2014 с пределами допускаемых значений доверительных границ относительной погрешности $\delta = 0,01\%$;

для датчиков с числом поверочных интервалов $n_{LC} > 3000$ ГПЭ единицы силы ГЭТ 32-2011 ($S \leq 5 \cdot 10^{-6}$, $\theta \leq 1 \cdot 10^{-5}$, $W_A \leq 5 \cdot 10^{-6}$, $W_B \leq 6 \cdot 10^{-6}$).

Допускается применение аналогичных средств поверки, обеспечивающих определение метрологических характеристик поверяемых СИ с требуемой точностью.

Знак поверки наносится в паспорт.

Лист № 5
Всего листов 5

ведения о методиках (методах) измерений
изложены в ГОСТ 8.631-2013 «ГСИ. Датчики весоизмерительные. Общие технические требования.
Методы испытаний».

**Нормативные и технические документы, устанавливающие требования к датчикам
весоизмерительным PR 6201, PR 6212**

ГОСТ 8.631-2013 ГСИ. Датчики весоизмерительные. Общие технические требования.
Методы испытаний

ГОСТ 8.021-2015 ГСИ. Государственная поверочная схема для средств измерений массы
Техническая документация фирмы "Minebea Intec GmbH", Германия

Изготовитель

Фирма «Minebea Intec GmbH», Германия
Адрес: Meiendorfer Strasse 205A, 22145 Hamburg, Germany
Телефон: +49.40.67960-238, факс: +49.40.67960-500
E-mail: juergen.stolte@minebea-intec.com

Испытательный центр

Федеральное государственное унитарное предприятие «Всероссийский научно-
исследовательский институт метрологии им. Д.И. Менделеева»

(ФГУП «ВНИИМ им. Д.И. Менделеева»)

Адрес: 190005, Санкт-Петербург, Московский пр., 19

Телефон: (812) 251-76-01, факс: (812) 713-01-14

Web-сайт: www.vniim.ru

E-mail: info@vniim.ru

Аттестат аккредитации ФГУП «ВНИИМ им. Д.И. Менделеева» по проведению испытаний
средств измерений в целях утверждения типа № RA.RU.311541 от 23.03.2016 г.

Заместитель
Руководителя Федерального
агентства по техническому
регулированию и метрологии



С.С. Голубев

М.п. « 12 » 2017 г.

12.13 DE-14-PC-PTB002

Physikalisch-Technische Bundesanstalt		
Braunschweig und Berlin		
		
Baueinheiten-Zertifikat		
<i>Parts Certificate</i>		
Ausgestellt für: <i>Issued to:</i>	Sartorius Mechatronics T&H GmbH	
	Meiendorfer Str. 205 22145 Hamburg	
Grundlage: <i>In accordance with:</i>	WELMEC 8.8 (2011-05), WELMEC 2.4 (2001-08), OIML R60 (2000), EN 45501 (1992), para. 8.1 & 3.5.4	
Baueinheiten: <i>Type of parts:</i>	Wägezelle <i>Load cell</i>	
Typbezeichnung: <i>Type designation:</i>	PR 6201	
Nr. der Bescheinigung: <i>Certificate No.:</i>	DE-14-PC-PTB002	
Anzahl der Seiten: <i>Number of pages:</i>	7	
Geschäftszeichen: <i>Reference No.:</i>	PTB-1.12-4066189	
Zertifizierung: <i>Certification:</i>	Braunschweig, 14.04.2014	Bewertung: <i>Evaluation:</i>
Im Auftrag <i>On behalf of PTB</i>	Siegel <i>Seal</i>	Im Auftrag <i>On behalf of PTB</i>
 Dr. Oliver Mack		 Jessica Denzel
<p>Zertifikate ohne Unterschrift und Siegel haben keine Gültigkeit. Dieses Zertifikat darf nur unverändert weiterverbreitet werden. Auszüge bedürfen der Genehmigung der Physikalisch-Technischen Bundesanstalt. <i>Certificates without signature and seal are not valid. This certificate may not be reproduced other than in full. Extracts may be taken only with the permission of the Physikalisch-Technische Bundesanstalt.</i></p>		
R3-000 35965		



Physikalisch-Technische Bundesanstalt

Seite 2 zum Baueinheiten-Zertifikat vom 14.04.2014, Zertifikat Nr: DE-14-PC-PTB002
 Page 2 of the Parts Certificate dated 14.04.2014, Certificate No.: DE-14-PC-PTB002

Zertifikatsgeschichte

/ Certificate history

Zertifikats-Ausgabe <i>Certificate release</i>	Datum <i>Date</i>	Wesentliche Änderungen <i>Essential changes</i>
DE-14-PC-PTB002	2014-04-14	Erstbescheinigung / <i>primary certificate</i>

Vorbemerkung

/ Preliminary remark

Dieses Zertifikat ist in Deutsch geschrieben. Im Fall von Unstimmigkeiten zwischen der deutschsprachigen Version und der englischen Übersetzung gilt die deutsche Version.

This certificate is written in German. In case of any conflict between the German language version and the English translation of it, the German version shall prevail.

1. Technische Daten

/ Technical Data

Die metrologischen Kenndaten der Wägezellen Typ PR 6201 sind in Tabelle 1 angegeben. Weitere technische Daten sind dem Datenblatt des Herstellers, Abschnitt 6 dieser Anlage, zu entnehmen.

The metrological characteristics of the load cells type PR 6201 are listed in Table 1. Further technical data are listed in the data sheet of the manufacturer in section 6 of this annex.

Tabelle 1: Wesentliche Kenndaten

/ Table 1: Essential data

Genauigkeitsklasse <i>Accuracy class</i>		C3	D1
Max. zul. Anzahl d. Teilungswerte <i>Maximum number of verification intervals</i>	n_{LC}	3000	1000
Kennwert <i>Rated output</i>	mV/V	1	
Nennlast <i>Nominal capacity</i>	E_{max}	t	2 / 3 / 5 / 10
Mindestteilungswert der Wägezelle <i>Minimum load cell verification interval</i>	$v_{min} = (E_{max} / Y)$	$E_{max} / 7000$ für/for $E_{max} = 2$ t; $E_{max} / 9000$ für/for $E_{max} = 3$ t; $E_{max} / 14000$ für/for $E_{max} \geq 5$ t	$E_{max} / 1750$ für/for $E_{max} = 0,5$ t; $E_{max} / 3500$ für/for $E_{max} = 1$ t; $E_{max} / 5000$ für/for $E_{max} \geq 2$ t
Vorlastsignalrückkehr <i>Minimum dead load output return</i>	$DR = (\frac{1}{2} \cdot E_{max} / Z)$	$\frac{1}{2} \cdot E_{max} / 3000$	$\frac{1}{2} \cdot E_{max} / 1000$
Erweiterter Temperaturbereich <i>extended temperature range</i>	°C	-10 ... +55	

Vorlast: / *Dead load:* 0% E_{max} ; Eingangswiderstand: / *Input impedance:* 650 Ω

2. Prüfungen

/ Tests

Die Richtigkeitsprüfungen, die Untersuchungen der Stabilität des Nullsignals, der Reproduzierbarkeit und des Kriechverhaltens im Temperaturbereich von -10°C bis +40°C, sowie zusätzlich bis +55°C und die barometrischen Prüfungen und die Prüfung der Messbeständigkeit bei zyklischer Feuchte-Wärme wurden nach OIML R60 (2000) mit dem Fehleranteil $p_{LC} = 0,7$ entsprechend Tabelle 2 ausgeführt.

The determination of the load cell error, the stability of the dead load output, repeatability and creep in the temperature range of -10°C to +40°C plus up to +55 °C as well as the tests of barometric pressure effects and the determination of the effects of cyclic damp heat have been performed according to OIML R60 (2000) with fraction $p_{LC} = 0.7$ as shown in Table 2.



Physikalisch-Technische Bundesanstalt

Seite 3 zum Baueinheiten-Zertifikat vom 14.04.2014, Zertifikat Nr: DE-14-PC-PTB002
Page 3 of the Parts Certificate dated 14.04.2014, Certificate No.: DE-14-PC-PTB002

Tabelle 2: Ausgeführte Prüfungen

/ Table 2: Tests performed

Prüfung / Test	R60 (2000)	geprüfte Muster tested samples	Ergebnis result
Temperaturprüfung und Wiederholbarkeit bei Temperature test and repeatability at (20°C / 40°C / 55°C* / -10°C / 20°C)	5.1.1; 5.4 A.4.1	0,5 t; 1 t; 2 t; 3 t; 5 t	+
Temperatureinfluss auf Vorlastsignal bei Temp. effect on min. dead load output at (20°C / 40°C / 55°C* / -10°C / 20°C)	5.5.1.3 A.4.1.16	0,5 t; 1 t; 2 t; 3 t; 5 t	+
Kriechprüfung bei Creep test at (20°C / 40°C / 55°C* / -10°C / 20°C)	5.3.1 A.4.2	0,5 t; 1 t; 2 t; 3 t; 5 t	+
Mindestvorlastsignalrückkehr bei Minimum dead load output return at (20°C / 40°C / 55°C* / -10°C / 20°C)	5.3.2 A.4.3	0,5 t; 1 t; 2 t; 3 t; 5 t	+
Auswirkung des Luftdrucks bei Umgebungstemperatur Barometric pressure effects at room temperature	5.5.2 A.4.4	0,5 t; 1 t; 2 t; 3 t; 5 t	+
Feuchteprüfung, zyklisch, Kennzeichnung CH oder (ohne) Damp heat test, cyclic, marked CH or (not marked)	5.5.3.1 A.4.5	0,5 t; 2 t	+

* zusätzliche, über Anforderung von OIML R60 hinausgehende Prüfung

Die folgenden Messergebnisse sind in der PTB hinterlegt: / Following test results are kept at PTB:

- Test Report No. PTB 1.12-4066189-1, 08.11.2013:
E_{max}=2 t; SN: 486750; C3; Y=7000; Z=3000; -10°C bis +40°C
- Test Report No. PTB 1.12-4066189-2, 08.11.2013:
E_{max}=2 t; SN: 486750; C3; Y=7000; Z=3000; -10°C bis +55°C
- Test Report No. PTB 1.12-4066189-3, 08.11.2013:
E_{max}=0,5 t; SN: 459599; D1; Y=1750; Z=1000; -10°C bis +40°C
- Test Report No. PTB 1.12-4066189-4, 08.11.2013:
E_{max}=0,5 t; SN: 459599; D1; Y=1750; Z=1000; -10°C bis +55°C
- Test Report No. PTB 1.12-4066189-5, 10.03.2014:
E_{max}=5 t; SN: 497389; C3; Y=14000; Z=3000; -10°C bis +40°C
- Test Report No. PTB 1.12-4066189-6, 10.03.2014:
E_{max}=5 t; SN: 497389; C3; Y=14000; Z=3000; -10°C bis +55°C
- Test Report No. PTB 1.12-4066189-7, 18.03.2014:
E_{max}=3 t; SN: 497546; C3; Y=9000; Z=3000; -10°C bis +40°C
- Test Report No. PTB 1.12-4066189-8, 18.03.2014:
E_{max}=3 t; SN: 497546; C3; Y=9000; Z=3000; -10°C bis +55°C
- Test Report No. PTB 1.12-4066189-9, 28.03.2014:
E_{max}=1 t; SN: 499727; C1; Y=3500; Z=1000; -10°C bis +40°C
- Test Report No. PTB 1.12-4066189-10, 28.03.2014:
E_{max}=1 t; SN: 499727; C1; Y=3500; Z=1000; -10°C bis +55°C



Physikalisch-Technische Bundesanstalt

Seite 4 zum Baueinheiten-Zertifikat vom 14.04.2014, Zertifikat Nr: DE-14-PC-PTB002
 Page 4 of the Parts Certificate dated 14.04.2014, Certificate No.: DE-14-PC-PTB002

3. Beschreibung der Wägezelle / Description of the load cell

Die Wägezellen der Baureihe PR 6201 sind Drucklast-Wägezellen in selbstzentrierender, pendelstützenförmiger Ausführung. Sie sind aus einem Tiefziehgehäuse aus rostfreiem Stahl hergestellt, die DMS-Applikation ist hermetisch gekapselt. Die wesentlichen Betriebsdaten sind dem Datenblatt in Abschnitt 6 dieser Anlage zu entnehmen.

The load cells of the series PR 6201 are compression load cells for self-centring pendulum applications. They are made of full stainless steel housing, the strain gauge application is hermetically sealed. Further essential characteristics are given in the data sheet, see section 6 of this annex.



Bild 1: Wägezelle Typ PR 6201

Figure 1: Load cell type PR 6201

Die Kennzeichnung auf dem Typenschild erfolgt entsprechend dem Beispiel:

The type designation is indicated as follows in the example on the name plate:

PR 6201 / 23 / C3

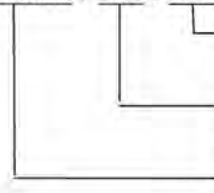

für Waagen der Klasse III, max. zulässige Anzahl der Teilungswerte in $n_{LC} / 1000$
 Nennlast $E_{max} = 2\,000\text{ kg}$, Kodierung: 2 = Zahlenwert, 3 = Anzahl der Nullen
 Wägezellen Typ

for weighing instruments class III, max. number of load cell intervals in $n_{LC} / 1000$
 maximum capacity $E_{max} = 2000\text{ kg}$;
 Code: 2 = numerical value, 3 = number of zeros
 load cell type



Physikalisch-Technische Bundesanstalt

Seite 5 zum Baueinheiten-Zertifikat vom 14.04.2014, Zertifikat Nr: DE-14-PC-PTB002
Page 5 of the Parts Certificate dated 14.04.2014, Certificate No.: DE-14-PC-PTB002

4. Dokumentation

/ Documentation

Die zu diesem Zertifikat gehörenden technischen Unterlagen des Zertifikatsinhabers sind im Zertifizierungs-Dokumentensatz ZDS-DE-14-PC-PTB002 der benannten Stelle hinterlegt. Ein von der benannten Stelle gestempeltes Inhaltsverzeichnis dieses Zertifizierungs-Dokumentensatzes wurde dem Zertifikatsinhaber zugeschickt.

The documents appending to this certificate are deposited at the notified body in the set of certification documentation No. ZDS-DE-14-PC-PTB002. The index of the set of certification documentation has been stamped by the notified body and it has been sent to the owner of the certificate.

5. Weitere Informationen

/ Further information

Fertigungsverfahren, Werkstoffe und Abdichtungen müssen den vorgestellten Mustern und der in der PTB hinterlegten Dokumentation entsprechen; Änderungen sind nur mit Zustimmung der PTB erlaubt.

Die im Datenblatt hinsichtlich Linearität, Umkehrspanne und Temperaturgang angegebenen Fehlergrenzen begrenzen maximal mögliche Einzelfehler eines Musters; der für jedes Muster zulässige Gesamtfehler aus diesen Größen ist durch die Fehlergrenze nach OIML R60 Nr. 5.1 (Hüllkurve) vorgegeben.

Die technischen Daten sowie die Abmessungen der Wägezellen sind im Abschnitt 6 in dieser Anlage enthalten und müssen beachtet werden. Die Wägezellen können nach DIN EN 45501 Nr. 4.12 auch in Waagen der Klasse (III) eingesetzt werden.

The manufacturing process, material and sealing of the produced load cells have to be in accordance with the tested patterns; changes are only allowed with the permission of the PTB.

The typical errors related to linearity, hysteresis and temperature coefficient as indicated in the data sheet point out possible single errors of a pattern; however, the overall error of each pattern is determined by the maximum permissible error according to OIML R60 No 5.1.

The technical data, the dimensions of the load cell are given in section 6 of this annex, have to be complied with. The load cells also can be used in weighing instruments of class (III) in accordance with DIN EN 45501 No. 4.12.



Physikalisch-Technische Bundesanstalt

Seite 6 zum Baueinheiten-Zertifikat vom 14.04.2014, Zertifikat Nr: DE-14-PC-PTB002
 Page 6 of the Parts Certificate dated 14.04.2014, Certificate No.: DE-14-PC-PTB002

6. Datenblatt und Abmessungen / Data sheet and dimensions

Kenndaten der Wägezellen-Familie / Specifications of the Load Cell Family

Genauigkeitsklasse nach OIML R60 <i>Accuracy class acc. to OIML R60</i>			C3	D1
Anzahl der Teilungswerte <i>Max. number of load cell verification intervals</i>	n_{LC}		3000	1000
Nennlast / <i>Nominal capacity</i>	E_{max}	t	2 / 3 / 5 / 10	0,5 / 1 / 2 / 3 / 5 / 10
Nennkennwert / <i>Rated output</i>	RO	mV/V	1 ± 0,07 %	1 ± 0,25 %
Ausgangssignal im unbelasteten Zustand <i>Load cell output signal under unloaded condition</i>	S_{min}	% RO	< 1	
Mindestteilungswert d. Wägezelle <i>Min. load cell verification interval</i>	V_{min}		$E_{max} / 7000$ für/for $E_{max} = 2$ t; $E_{max} / 9000$ für/for $E_{max} = 3$ t; $E_{max} / 14000$ für/for $E_{max} \geq 5$ t	$E_{max} / 1750$ für/for $E_{max} = 0,5$ t; $E_{max} / 3500$ für/for $E_{max} = 1$ t; $E_{max} / 5000$ für/for $E_{max} \geq 2$ t
Kriechen (30 Min) / <i>Creep (30 min)</i>	d_{cr}	% RO	< 0,015	
Linearitätsabweichung / <i>Non-Linearity</i>	d_{lin}	% RO	< 0,01	
Reproduzierbarkeit / <i>Repeatability error</i>	δ_{rt}	% RO	< 0,005	
Relative Umkehrspanne / <i>Hysteresis error</i>	δ_{hy}	% RO	< 0,015	
Temperaturkoeffizient d. Kennwertes <i>Temperature coefficient of sensitivity</i>	TC_{RO}	% RO / 10 K	< 0,01	
Temperaturkoeffizient d. Mindestvorlastsignals <i>Temperature coefficient of minimum dead load output</i>	TC_{Smin}	% RO / 10 K	< 0,01	
Mindestvorlast / <i>Minimum dead load</i>	E_{min}	% E_{max}	0	
Gebrauchslast / <i>Maximum usable load</i>	E_{u}	% E_{max}	200	
Bruchlast / <i>Destructive load</i>	E_b	% E_{max}	> 500	
Grenzxentrität / <i>Permissible eccentricity</i>	S_{ex}	mm	10	
Nennmessweg / <i>Nominal deflection</i>	S_{nom}	mm	< 0,5	
Maximale Speisespannung <i>Excitation voltage, maximum</i>	U_{max}	V	32	
Nennbereich der Speisespannung <i>Nominal range of excitation voltage</i>	B_U	V	4 – 24	
Eingangswiderstand / <i>Input resistance</i>	R_{LC}	Ω	650 ± 6	
Ausgangswiderstand / <i>Output resistance</i>	R_{out}	Ω	610 ± 0,5	610 ± 1
Isolationswiderstand / <i>Insulation resistance</i>	R_{is}	M Ω	> 5000 (100 VDC)	
Nenntemperaturbereich / <i>Nominal temperature range</i>	B_T	$^{\circ}C$	- 10 ... + 55	
Gebrauchstemperaturbereich / <i>Operating temperature range</i>	B_{Tu}	$^{\circ}C$	- 40 ... + 95	
Lagertemperaturbereich / <i>Storage temperature range</i>	B_S	$^{\circ}C$	- 40 ... + 95	
Material des Gehäuses / <i>Material of load cell housing</i>			1.4301 (DIN 17440)	
Schutzart nach DIN EN 60529 <i>Protection according to DIN EN 60529</i>			IP68	
Kapselung / <i>Sealing</i>			hermetisch verschweißt / <i>hermetic sealing</i>	

Kabelanschluss

Die Wägezelle hat ein 4-adriges, abgeschirmtes Kabel.

Wiring

The load cell is provided with a shielded 4 conductor cable.

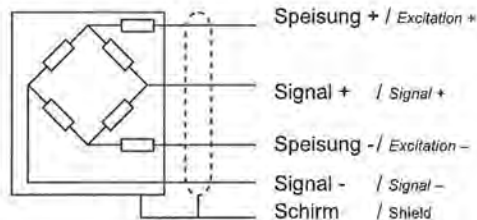



Physikalisch-Technische Bundesanstalt

Seite 7 zum Baueinheiten-Zertifikat vom 14.04.2014, Zertifikat Nr: DE-14-PC-PTB002
Page 7 of the Parts Certificate dated 14.04.2014, Certificate No.: DE-14-PC-PTB002

Anschlussbelegung

/ Connections

Anschlussbelegung Connections	4-Leiter 4-wires
Speisung / Excitation +	rot / red
Speisung / Excitation -	blau / blue
Signal / Signal +	grün / green
Signal / Signal -	grau / grey
Schirm / Shield	abisoliert / stripped
Kabellänge / Cable length	auf dem Typenschild der Wägezelle / on the name plate of the load cell
Durchmesser / Diameter	5 mm

Wägezellen-Abmessungen in mm

/ Load cell dimensions in mm

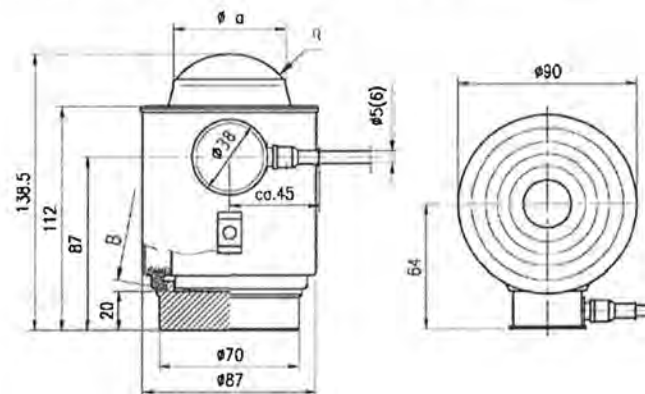

E_{\max}	in mm	a	R	B
0.5 t - 2 t		24	15	150
3 t - 10 t		34	15	150

Bild 2: Abmessungen der Wägezelle Typ PR 6201 / Figure 2: Dimensions of the load cell type PR 6201

Physikalisch-Technische Bundesanstalt
Bundesallee 100
38116 Braunschweig
DEUTSCHLAND

Abbestraße 2-12
10587 Berlin
DEUTSCHLAND

12.14 DE-14-PC-PTB003



Physikalisch-Technische Bundesanstalt
 Braunschweig und Berlin



Baueinheiten-Zertifikat
Parts Certificate

Ausgestellt für: <i>Issued to:</i>	Sartorius Mechatronics T&H GmbH Meiendorfer Str. 205 22145 Hamburg	
Grundlage: <i>In accordance with:</i>	WELMEC 8.8 (2011-05), WELMEC 2.4 (2001-08), OIML R60 (2000), EN 45501 (1992), para. 8.1 & 3.5.4	
Baueinheiten: <i>Type of parts:</i>	Wägezelle <i>Load cell</i>	
Typbezeichnung: <i>Type designation:</i>	PR 6201	
Nr. der Bescheinigung: <i>Certificate No.:</i>	DE-14-PC-PTB003	
Anzahl der Seiten: <i>Number of pages:</i>	6	
Geschäftszeichen: <i>Reference No.:</i>	PTB-1.12-4066192	
Zertifizierung: <i>Certification:</i>	Braunschweig, 14.04.2014	
Bewertung: <i>Evaluation:</i>	(Empty)	
Im Auftrag <i>On behalf of PTB</i>	Siegel <i>Seal</i>	Im Auftrag <i>On behalf of PTB</i>
 Dr. Oliver Mack		 Jessica Denzel

Zertifikate ohne Unterschrift und Siegel haben keine Gültigkeit. Dieses Zertifikat darf nur unverändert weiterverbreitet werden. Auszüge bedürfen der Genehmigung der Physikalisch-Technischen Bundesanstalt.
 Certificates without signature and seal are not valid. This certificate may not be reproduced other than in full. Extracts may be taken only with the permission of the Physikalisch-Technische Bundesanstalt.

R3-000 35965



Physikalisch-Technische Bundesanstalt

Seite 2 zum Baueinheiten-Zertifikat vom 14.04.2014, Zertifikat Nr: DE-14-PC-PTB003
Page 2 of the Parts Certificate dated 14.04.2014, Certificate No.: DE-14-PC-PTB003

Zertifikatsgeschichte

/ Certificate history

Zertifikats-Ausgabe Certificate release	Datum Date	Wesentliche Änderungen Essential changes
DE-14-PC-PTB003	2014-04-14	Erstbescheinigung / primary certificate

Vorbemerkung

/ Preliminary remark

Dieses Zertifikat ist in Deutsch geschrieben. Im Fall von Unstimmigkeiten zwischen der deutschsprachigen Version und der englischen Übersetzung gilt die deutsche Version.

This certificate is written in German. In case of any conflict between the German language version and the English translation of it, the German version shall prevail.

1. Technische Daten

/ Technical Data

Die metrologischen Kenndaten der Wägezellen Typ PR 6201 sind in Tabelle 1 angegeben. Weitere technische Daten sind dem Datenblatt des Herstellers, Abschnitt 6 dieser Anlage, zu entnehmen.

The metrological characteristics of the load cells type PR 6201 are listed in Table 1. Further technical data are listed in the data sheet of the manufacturer in section 6 of this annex.

Tabelle 1: Wesentliche Kenndaten

/ Table 1: Essential data

Genauigkeitsklasse Accuracy class		D1	C3	C4	C5	C6
Max. zul. Anzahl d. Teilungswerte Maximum number of verification intervals	n_{LC}	1000	3000	4000	5000	6000
Nennlast Nominal capacity	E_{max}	20 / 30 / 50 / 60 / 75				20 / 30
Mindestteilungswert d. Wägezelle Minimum load cell verification interval	$V_{min} = (E_{max} / Y)$	$E_{max} / 5000$	$E_{max} / 14000$	$E_{max} / 20000$		
Vorlastsignlrückkehr Minimum dead load output return	$DR = (\frac{1}{2} \cdot E_{max} / Z)$	$\frac{1}{2} \cdot E_{max} / 1000$	$\frac{1}{2} \cdot E_{max} / 6000$	$\frac{1}{2} \cdot E_{max} / 8000$		
Erweiterter Temperaturbereich extended temperature range	°C	-10 ... +55				

Vorlast: / Dead load: $0\% \cdot E_{max}$; Eingangswiderstand: / Input impedance: 650 Ω

2. Prüfungen

/ Tests

Die Richtigkeitsprüfungen, die Untersuchungen der Stabilität des Nullsignals, der Reproduzierbarkeit und des Kriechverhaltens im Temperaturbereich von -10°C bis +40°C, sowie zusätzlich bis +55°C und die barometrischen Prüfungen und die Prüfung der Messbeständigkeit bei zyklischer Feuchte-Wärme wurden nach OIML R60 (2000) mit dem Fehleranteil $p_{LC} = 0,7$ entsprechend Tabelle 2 ausgeführt.

The determination of the load cell error, the stability of the dead load output, repeatability and creep in the temperature range of -10°C to +40°C plus up to +55 ° C as well as the tests of barometric pressure effects and the determination of the effects of cyclic damp heat have been performed according to OIML R60 (2000) with fraction $p_{LC} = 0.7$ as shown in Table 2.



Physikalisch-Technische Bundesanstalt

Seite 3 zum Baueinheiten-Zertifikat vom 14.04.2014, Zertifikat Nr: DE-14-PC-PTB003
 Page 3 of the Parts Certificate dated 14.04.2014, Certificate No.: DE-14-PC-PTB003

Tabelle 2: Ausgeführte Prüfungen / Table 2: Tests performed

Prüfung / Test	R60 (2000)	geprüfte Muster / tested samples	Ergebnis / result
Temperaturprüfung und Wiederholbarkeit bei <i>Temperature test and repeatability at (20°C / 40°C / 55°C* / -10°C / 20°C)</i>	5.1.1; 5.4 A.4.1	20 t	+
Temperatureinfluss auf Vorlastsignal bei <i>Temp. effect on min. dead load output at (20°C / 40°C / 55°C* / -10°C / 20°C)</i>	5.5.1.3 A.4.1.16	20 t	+
Kriechprüfung bei <i>Creep test at (20°C / 40°C / 55°C* / -10°C / 20°C)</i>	5.3.1 A.4.2	20 t	+
Mindestvorlastsignalrückkehr bei <i>Minimum dead load output return at (20°C / 40°C / 55°C* / -10°C / 20°C)</i>	5.3.2 A.4.3	20 t	+
Auswirkung des Luftdrucks bei Umgebungstemperatur <i>Barometric pressure effects at room temperature</i>	5.5.2 A.4.4	20 t	+
Feuchteprüfung, zyklisch, Kennzeichnung CH oder (ohne) <i>Damp heat test, cyclic, marked CH or (not marked)</i>	5.5.3.1 A.4.5	20 t	+

* zusätzliche, über Anforderung von OIML R60 hinausgehende Prüfung

Die folgenden Messergebnisse sind in der PTB hinterlegt: / Following test results are kept at PTB:

- Test Report No. PTB 1.12-4066192-1, 18.03.2014:
 $E_{max}=20\text{ t}$; SN: 47853; C6; Y=20000; Z=8000; -10°C bis +40°C;
- Test Report No. PTB 1.12-4066192-2, 18.03.2014:
 $E_{max}=20\text{ t}$; SN: 47853; C6; Y=20000; Z=8000; -10°C bis +55°C;

3. Beschreibung der Wägezelle / Description of the load cell

Die Wägezellen der Baureihe PR 6201 sind Drucklast-Wägezellen in selbstzentrierender, pendelstützenförmiger Ausführung. Sie sind aus einem Tiefziehgehäuse aus rostfreiem Stahl hergestellt, die DMS-Applikation ist hermetisch gekapselt. Die wesentlichen Betriebsdaten sind dem Datenblatt in Abschnitt 6 dieser Anlage zu entnehmen.

The load cells of the series PR 6201 are compression load cells for self-centring pendulum applications. They are made of full stainless steel housing, the strain gauge application is hermetically sealed. Further essential characteristics are given in the data sheet, see section 6 of this annex.



Bild 1: Wägezelle Typ PR 6201

/ Figure 1: Load cell type PR 6201



Physikalisch-Technische Bundesanstalt

Seite 4 zum Baueinheiten-Zertifikat vom 14.04.2014, Zertifikat Nr.: DE-14-PC-PTB003
Page 4 of the Parts Certificate dated 14.04.2014, Certificate No.: DE-14-PC-PTB003

Die Kennzeichnung auf dem Typenschild erfolgt entsprechend dem Beispiel:

The type designation is indicated as follows in the example on the name plate:

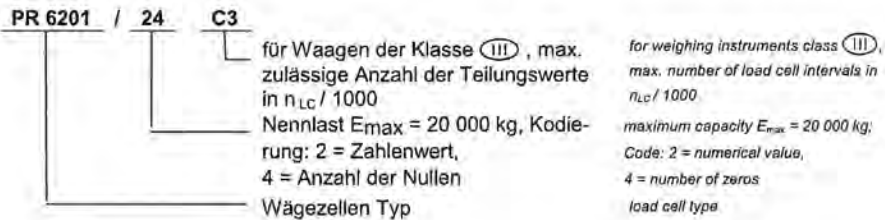

4. Dokumentation

/ Documentation

Die zu diesem Zertifikat gehörenden technischen Unterlagen des Zertifikatsinhabers sind im Zertifizierungs-Dokumentensatz ZDS-DE-14-PC-PTB003 der benannten Stelle hinterlegt. Ein von der benannten Stelle gestempeltes Inhaltsverzeichnis dieses Zertifizierungs-Dokumentensatzes wurde dem Zertifikatsinhaber zugeschickt.

The documents appending to this certificate are deposited at the notified body in the set of certification documentation No. ZDS-DE-14-PC-PTB003. The index of the set of certification documentation has been stamped by the notified body and it has been sent to the owner of the certificate.

5. Weitere Informationen

/ Further information

Fertigungsverfahren, Werkstoffe und Abdichtungen müssen den vorgestellten Mustern und der in der PTB hinterlegten Dokumentation entsprechen; Änderungen sind nur mit Zustimmung der PTB erlaubt.

Die im Datenblatt hinsichtlich Linearität, Umkehrspanne und Temperaturgang angegebenen Fehlergrenzen begrenzen maximal mögliche Einzelfehler eines Musters; der für jedes Muster zulässige Gesamtfehler aus diesen Größen ist durch die Fehlergrenze nach OIML R60 Nr. 5.1 (Hüllkurve) vorgegeben.

Die technischen Daten sowie die Abmessungen der Wägezellen sind im Abschnitt 6 in dieser Anlage enthalten und müssen beachtet werden. Die Wägezellen können nach DIN EN 45501 Nr. 4.12 auch in Waagen der Klasse (III) eingesetzt werden.

The manufacturing process, material and sealing of the produced load cells have to be in accordance with the tested patterns; changes are only allowed with the permission of the PTB.

The typical errors related to linearity, hysteresis and temperature coefficient as indicated in the data sheet point out possible single errors of a pattern; however, the overall error of each pattern is determined by the maximum permissible error according to OIML R60 No 5.1.

The technical data, the dimensions of the load cell are given in section 6 of this annex, have to be complied with. The load cells also can be used in weighing instruments of class (III) in accordance with DIN EN 45501 No. 4.12.



Physikalisch-Technische Bundesanstalt

Seite 5 zum Baueinheiten-Zertifikat vom 14.04.2014, Zertifikat Nr: DE-14-PC-PTB003
 Page 5 of the Parts Certificate dated 14.04.2014, Certificate No.: DE-14-PC-PTB003

6. Datenblatt und Abmessungen

/ Data sheet and dimensions

Kenndaten der Wägezellen-Familie

/ Specifications of the Load Cell Family

Genauigkeitsklasse nach OIML R60 <i>Accuracy class acc. to OIML R60</i>		D1	C3	C4	C5	C6
Anzahl der Teilungswerte <i>Max. number of load cell verification intervals</i>	n_{LC}	1000	3000	4000	5000	6000
Nennlast / <i>Nominal capacity</i>	E_{max}	t	20 / 30 / 50 / 60 / 75			20 / 30
Nennkennwert / <i>Rated output</i>	RO	mV/V	1 für/for $E_{max} = 20$ t, 30 t; 2 für/for $E_{max} = 50$ t; 2,4 für/for $E_{max} = 60$ t; 3 für/for $E_{max} = 75$ t			
				1,5 für/for $E_{max} \geq 60$ t	1,5 für/for $E_{max} \geq 50$ t	
Ausgangssignal im unbelasteten Zustand <i>Load cell output signal under unloaded condition</i>	S_{min}	%·RO	< 1			
Mindestteilungswert d. Wägezelle <i>Min. load cell verification interval</i>	v_{min}		$E_{max} / 5000$	$E_{max} / 14000$	$E_{max} / 20000$	
Kriechen (30 Min) / <i>Creep (30 min)</i>	d_{cr}	%·RO	< 0,03	< 0,015	< 0,0125	< 0,010
Linearitätsabweichung / <i>Non-Linearity</i>	d_{lin}	%·RO	< 0,03	< 0,01		
Reproduzierbarkeit / <i>Repeatability error</i>	d_{rt}	%·RO	< 0,01	< 0,005		
Relative Umkehrspanne / <i>Hysteresis error</i>	d_{hy}	%·RO	< 0,04	< 0,015	< 0,0125	< 0,010
Temperaturkoeffizient d. Kennwertes <i>Temperature coefficient of sensibility</i>	TC_{RO}	%RO / 10 K	< 0,03	< 0,01	< 0,008	< 0,007
Temperaturkoeffizient d. Mindestvorlastsignals <i>Temperature coefficient of minimum dead load output</i>	TC_{Bn} in	%RO / 10 K	< 0,028	< 0,01	< 0,007	
Vorlastsignalrückkehr <i>Minimum dead load output return (MDLOR)</i>	DR		$\frac{1}{2} E_{max} / 1000$	$\frac{1}{2} E_{max} / 6000$	$\frac{1}{2} E_{max} / 8000$	
					$\frac{1}{2} E_{max} / 6000$ ab/from 50 t	
Mindestvorlast / <i>Minimum dead load</i>	E_{min}	%· E_{max}	0			
Gebrauchslast / <i>Maximum usable load</i>	E_u	t	40 t für/for $E_{max} = 20$ t; 60 t für/for $E_{max} = 30$ t; 75 t für/for $E_{max} = 50$ t, 60 t, 75 t			
Bruchlast / <i>Destructive load</i>	E_b	t	> 100 für/for 20 t; > 150 ab/from 30 t			
Grenzexzentrizität / <i>Permissible eccentricity</i>	S_{ax}	mm	10			
Nennmessweg / <i>Nominal deflection</i>	s_{nom}	mm	0,4 für/for $E_{max} = 20$ t; 0,5 für/for $E_{max} = 30$ t; 0,8 für/for $E_{max} = 50$ t; 0,9 für/for $E_{max} = 60$ t; 1,1 für/for $E_{max} = 75$ t			
Maximale Speisespannung <i>Excitation voltage, maximum</i>	U_{max}	V	32			
Nennbereich der Speisespannung <i>Nominal range of excitation voltage</i>	B_U	V	4 – 24			
Eingangswiderstand / <i>Input resistance</i>	R_{LC}	Ω	650 \pm 6			
Ausgangswiderstand / <i>Output resistance</i>	R_{out}	Ω	610 \pm 1	610 \pm 0,5		
				460 \pm 0,5 für/for $E_{max} = 50$ t		
				385 \pm 0,5 für/for $E_{max} = 60$ t; 310 \pm 0,5 für/for $E_{max} = 75$ t		
Isolationswiderstand / <i>Insulation resistance</i>	R_{is}	M Ω	> 5000 (100 VDC)			
Nenntemperaturbereich / <i>Nominal temperature range</i>	B_T	$^{\circ}C$	- 10 ... + 55			
Gebrauchstemperaturbereich <i>Operating temperature range</i>	B_{Tn}	$^{\circ}C$	- 40 ... + 95			
Lagertemperaturbereich / <i>Storage temperature range</i>	B_{Tl}	$^{\circ}C$	- 40 ... + 95			
Material des Gehäuses / <i>Material of load cell housing</i>			1.4301 (DIN 17440)			
Schutzart nach DIN EN 60529 <i>Protection according to DIN EN 60529</i>			IP68			
Kapselung / <i>Sealing</i>			hermetisch verschweißt / <i>hermetic sealing</i>			



Physikalisch-Technische Bundesanstalt

Seite 6 zum Baueinheiten-Zertifikat vom 14.04.2014, Zertifikat Nr.: DE-14-PC-PTB003
 Page 6 of the Parts Certificate dated 14.04.2014, Certificate No.: DE-14-PC-PTB003

Kabelanschluss

Die Wägezelle hat ein 4-adriges, abgeschirmtes Kabel.

Wiring

The load cell is provided with a shielded 4 conductor cable.

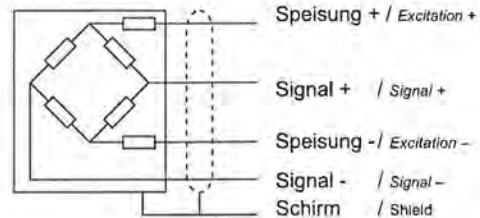

Anschlussbelegung

/ Connections

Anschlussbelegung Connections	4-Leiter 4-wires
Speisung / Excitation +	rot / red
Speisung / Excitation -	blau / blue
Signal / Signal +	grün / green
Signal / Signal -	grau / grey
Schirm / Shield	abisoliert / stripped
Kabellänge / Cable length	auf dem Typenschild der Wägezelle / on name plate of the load cell
Durchmesser / Diameter	5 mm

Wägezellen-Abmessungen in mm

/ Load cell dimensions in mm

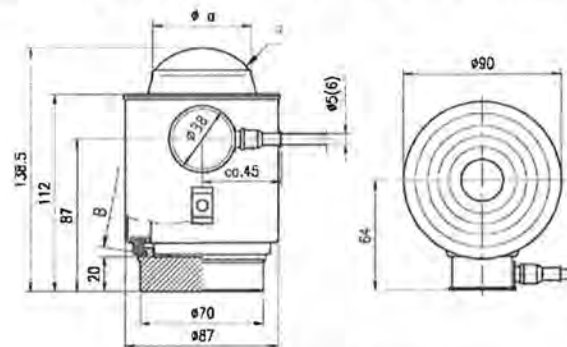

a	R	B
in mm		
56	35	220

Bild 2: Abmessungen der Wägezelle Typ PR 6201 / Figure 2: Dimensions of the load cell type PR 6201

Physikalisch-Technische Bundesanstalt
 Bundesallee 100
 38116 Braunschweig
 DEUTSCHLAND

Abbestraße 2-12
 10587 Berlin
 DEUTSCHLAND

12.15 R60/2000-DE1-14.01



**Physikalisch-Technische Bundesanstalt
Braunschweig und Berlin**
Nationales Metrologieinstitut



OIML Certificate No.
R60/2000-DE1-14.01
Revision 1

Member State of OIML
Germany

OIML CERTIFICATE OF CONFORMITY

Issuing Authority

Name: Physikalisch-Technische Bundesanstalt
 Address: Bundesallee 100, 38116 Braunschweig
 Person responsible: Dr. O. Mack

Applicant

Name: Sartorius Mechatronics T & H GmbH
 Address: Meiendorfer Str. 205, 22145 Hamburg

Manufacturer of the certified type is the applicant.

Identification of the certified type

Compression Load Cell Type: PR 6201
 Further characteristics see page 2

This Certificate attests the conformity of the above identified type (represented by the sample or samples identified in the associated Test Report) with the requirements of the following Recommendation of the International Organization of Legal Metrology (OIML):

R60, edition 2000
 for accuracy class(es) D1, C1, C3, C4, C5, C6

This Certificate relates only to the metrological and technical characteristics of the type of instrument covered by the relevant OIML Recommendation identified above.

This Certificate does not bestow any form of legal international approval.

R3-0033

Page 1 of 3 pages



OIML Certificate No.
R60/2000-DE1-14.01
Revision 1

The conformity was established by the results of tests and examinations provided in the associated Test Reports

- No. 4069269-1 that includes 20 pages
- No. 4069269-2 that includes 19 pages
- No. 4069269-3 that includes 20 pages
- No. 4069269-4 that includes 19 pages
- No. 4069269-5 that includes 20 pages
- No. 4069269-6 that includes 19 pages
- No. 4069269-7 that includes 20 pages
- No. 4069269-8 that includes 19 pages
- No. 4069269-9 that includes 19 pages
- No. 4069269-10 that includes 19 pages
- No. 4069269-11 that includes 20 pages
- No. 4069269-12 that includes 20 pages

The Issuing Authority

Dr. O. Mack
Head of Working Group

10.03.2017

The OIML Member

Dr. R. Schwartz
Vice-president

10.03.2017

Table 1a: $E_{max} = 0.5 t \dots 10 t$

Accuracy class			C3	D1
Maximum number of verification intervals	n_{LC}		3000	1000
Rated output		mVV	1	
Nominal capacity	E_{max}	t	2 / 3 / 5 / 10	0,5 / 1 / 2 / 3 / 5 / 10
Minimum load cell verification interval	$V_{min} = (E_{max} / Y)$		$E_{max} / 7000$ for $E_{max} = 2 t$; $E_{max} / 9000$ for $E_{max} = 3 t$; $E_{max} / 14000$ for $E_{max} \geq 5 t$	$E_{max} / 1750$ for $E_{max} = 0,5 t$; $E_{max} / 3500$ for $E_{max} = 1 t$; $E_{max} / 5000$ for $E_{max} \geq 2 t$
Minimum dead load output return	$DR = (\frac{1}{2} \cdot E_{max} / Z)$		$\frac{1}{2} \cdot E_{max} / 3000$	$\frac{1}{2} \cdot E_{max} / 1000$
extended temperature range		°C	-10 ... +55	

Dead load: $0\% \cdot E_{max}$; Input impedance: 650 Ω



OIML Certificate No.
R60/2000-DE1-14.01
Revision 1

Table 1b: $E_{max} = 20\text{ t} \dots 75\text{ t}$

<i>Accuracy class</i>		D1	C3	C4	C5	C6
<i>Maximum number of verification intervals</i>	n _{LC}	1000	3000	4000	5000	6000
<i>Nominal capacity</i>	E_{max}	t	20 / 30 / 50 / 60 / 75			20 / 30
<i>Minimum load cell verification interval</i>	$V_{min} = (E_{max} / Y)$	$E_{max} / 5000$	$E_{max} / 14000$	$E_{max} / 20000$		
<i>Minimum dead load output return</i>	DR = $(\frac{1}{2} \cdot E_{max} / Z)$	$\frac{1}{2} \cdot E_{max} / 1000$	$\frac{1}{2} \cdot E_{max} / 6000$	$\frac{1}{2} \cdot E_{max} / 8000$		
				$\frac{1}{2} \cdot E_{max} / 6000$ for $E_{max} \geq 50\text{ t}$		
<i>extended temperature range</i>	°C	-10 ... +55				

Dead load: $0\% \cdot E_{max}$; Input impedance: 650 Ω

Important note: Apart from the mention of the Certificate's reference number and the name of the OIML Member State in which the Certificate is issued, partial quotation of the Certificate and of the associated Test Report(s) is not permitted, although either may be reproduced in full.

12.16 NMI S333A

NMI S333A
Rev 5



Australian Government
Department of Industry,
Innovation and Science

**National
Measurement
Institute**

Supplementary Certificate of Approval

NMI S333A

Issued by the Chief Metrologist under Regulation 60
of the
National Measurement Regulations 1999

This is to certify that an approval for use for trade has been granted in respect of
the instruments herein described.

GWT Global Weighing PR 6201 and PR 6221 Series Load Cells
submitted by Minebea Intec GmbH
(formerly Sartorius Mechatronics T&H GmbH)
Meiendorfer Strasse 205A
22145 Hamburg
Germany

NOTE: This Certificate relates to the suitability of the pattern of the instrument for
use as a legal measuring instrument only in respect of its metrological
characteristics. This Certificate does not constitute or imply any guarantee of
compliance by the manufacturer or any other person with any requirements
regarding safety.

This approval has been granted with reference to document NMI R 60,
Metrological Regulation for Load Cells, dated July 2004.

This approval becomes subject to review on **1/09/22**, and then every
5 years thereafter.

DOCUMENT HISTORY

Rev	Reason/Details	Date
0	Pattern approved – interim certificate issued	17/08/01
1	Pattern approved – certificate issued	18/02/02
2	Pattern amended (submitter details) & reviewed – notification of change issued	1/02/07
3	Pattern amended (submitter details) & reviewed – notification of change issued	31/05/11
4	Pattern updated – variant 1 approved – certificate issued	22/10/12
5	Pattern & variant 1 reviewed, amended (pattern & submitter details) – certificate issued	21/07/17

Page 1 of 9

NMI S333A
Rev 5

CONDITIONS OF APPROVAL

General

Instruments purporting to comply with this approval shall be marked with pattern approval number 'NMI (or NSC) S333A' and only by persons authorised by the submitter.

Instruments incorporating a component purporting to comply with this approval shall be marked 'NMI (or NSC) S333A' in addition to the approval number of the instrument, and only by persons authorised by the submitter.

It is the submitter's responsibility to ensure that all instruments marked with this approval number are constructed as described in the documentation lodged with the National Measurement Institute (NMI) and with the relevant Certificate of Approval and Technical Schedule. Failure to comply with this Condition may attract penalties under Section 19B of the National Measurement Act and may result in cancellation or withdrawal of the approval, in accordance with document NMI P 106.

The values of the performance criteria (maximum number of scale intervals etc.) applicable to an instrument incorporating the pattern approved herein shall be within the limits specified herein and in any approval documentation for the other components.

Signed by a person authorised by the Chief Metrologist to exercise their powers under Regulation 60 of the *National Measurement Regulations 1999*.



Stephen Horrocks

NMI S333A
Rev 5

TECHNICAL SCHEDULE No S333A

1. Description of Pattern**approved on 17/08/01
amended on 21/07/17**

The GWT Global Weighing PR 6201 and PR 6221 series of load cells of up to 30 000 kg maximum capacity (Tables 1 to 5) approved for use with up to 3000 verification intervals (C3 load cells) or with up to 4000 verification intervals (C4 load cells). May also be known as Sartorius or Minebea Intec Instruments of the same models.

Figures 1 and 2 show examples of typical PR 6201 and PR 6221 series load cells.

1.1 Method of Mounting

Mounting is to be in accordance with the manufacturer's instructions and as shown in Figures 3 and 4. (Note that there are different load cell profiles for different models of load cell.)

1.2 Markings

Each load cell is marked with the following:

Manufacturer's mark, or name written in full	Minebea Intec, Germany
Model number
Serial number
Pattern approval mark	NMI or NSC S333A
Maximum capacity E_{max} kg or t
Cable length m

1.3 Table of Specifications

Specifications for the patterns are given in Tables 1 to 5.

2. Description of Variant 1**approved on 22/10/12
amended on 21/07/17**

A Sartorius Mechatronics model PR6201/54 C3 load cell of 50 000 kg maximum capacity load cell (Table 6).

Page 3 of 9

NMI S333A
Rev 5

TABLE 1

Manufacturer: GWT Global Weighing (aka Sartorius or Minebea Intec)

Type:	PR 6201/23 C3	PR 6201/33 C3	PR 6201/53 C3
Maximum capacity, E_{max} kg	2000	3000	5000
Accuracy class	C	C	C
Maximum number of verification intervals	3000	3000	3000
Minimum value of verification interval, V_{min} kg	0.29	0.33	0.35
Minimum dead load output return value (DR) kg	0.33	0.5	0.83
Output rating (nominal) mV/V	1	1	1
Input impedance (nominal) Ω	650	650	650
Supply voltage (AC or DC) V	4 - 24	4 - 24	4 - 24
Cable length (± 0.1 m) m	Manufactured in various lengths between 10 and 100 metres; the cable length is marked on the data plate.		
Number of leads (plus shield)	4 or 6	4 or 6	4 or 6

TABLE 2

Manufacturer: GWT Global Weighing (aka Sartorius or Minebea Intec)

Type:	PR 6201/14 C3	PR 6201/24 C3	PR 6201/34 C3
Maximum capacity, E_{max} kg	10 000	20 000	30 000
Accuracy class	C	C	C
Maximum number of verification intervals	3000	3000	3000
Minimum value of verification interval, V_{min} kg	0.71	1.43	2.14
Minimum dead load output return value (DR) kg	1.67	1.67	2.5
Output rating (nominal) mV/V	1	1	1
Input impedance (nominal) Ω	650	650	650
Supply voltage (AC or DC) V	4 - 24	4 - 24	4 - 24
Cable length (± 0.1 m) m	Manufactured in various lengths between 10 and 100 metres; the cable length is marked on the data plate.		
Number of leads (plus shield)	4 or 6	4 or 6	4 or 6

NMI S333A
Rev 5

TABLE 3

Manufacturer: GWT Global Weighing (aka Sartorius or Minebea Intec)		
Type:	PR 6201/24 C4	PR 6201/34 C4
Maximum capacity, E_{max} kg	20 000	30 000
Accuracy class	C	C
Maximum number of verification intervals	4000	4000
Minimum value of verification interval, V_{min} kg	1.0	1.5
Minimum dead load output return value (DR) kg	1.25	1.88
Output rating (nominal) mV/V	1	1
Input impedance (nominal) Ω	650	650
Supply voltage (AC or DC) V	4 - 24	4 - 24
Cable length (± 0.1 m) m	Manufactured in various lengths between 12 and 100 metres; the cable length is marked on the data plate.	
Number of leads (plus shield)	4 or 6	4 or 6

TABLE 4

Manufacturer: GWT Global Weighing (aka Sartorius or Minebea Intec)		
Type:	PR6221/20t C3	PR6221/30t C3
Maximum capacity, E_{max} kg	20 000	30 000
Accuracy class	C	C
Maximum number of verification intervals	3000	3000
Minimum value of verification interval, V_{min} kg	1.43	2.14
Minimum dead load output return value (DR) kg	1.67	2.5
Output rating (nominal) mV/V	1	1
Input impedance (nominal) Ω	1080	1080
Supply voltage (AC or DC) V	4 - 24	4 - 24
Cable length (± 0.1 m) m	Manufactured in various lengths between 16 and 100 metres; the cable length is marked on the data plate.	
Number of leads (plus shield)	4 or 6	4 or 6

Page 5 of 9

NMI S333A
Rev 5

TABLE 5

Manufacturer: GWT Global Weighing (aka Sartorius or Minebea Intec)

Type:	PR6221/20t C4	PR6221/30t C4
Maximum capacity, E_{max} kg	20 000	30 000
Accuracy class	C	C
Maximum number of verification intervals	4000	4000
Minimum value of verification interval, V_{min} kg	1.0	1.5
Minimum dead load output return value (DR) kg	1.25	1.88
Output rating (nominal) mV/V	1	1
Input impedance (nominal) Ω	1080	1080
Supply voltage (AC or DC) V	4 - 24	4 - 24
Cable length (± 0.1 m) m	Manufactured in various lengths between 16 and 100 metres; the cable length is marked on the data plate.	
Number of leads (plus shield)	4 or 6	4 or 6

TABLE 6

Manufacturer: GWT Global Weighing (aka Sartorius or Minebea Intec)

Type:	PR 6201/54 C3
Maximum capacity, E_{max} kg	50 000
Accuracy class	C
Maximum number of verification intervals	3000
Minimum value of verification interval, V_{min} kg	3.57
Minimum dead load output return value (DR) kg	4.17
Output rating (nominal) mV/V	2
Input impedance (nominal) Ω	650
Supply voltage (AC or DC) V	4 - 24
Cable length (± 0.1 m) m	Manufactured in various lengths between 12 and 100 metres; the cable length is marked on the data plate.
Number of leads (plus shield)	4 or 6

NMI S333A
Rev 5

FIGURE S333A – 1



GWT Global Weighing Model PR 6201/23 C3 Load Cell

FIGURE S333A – 2



GWT Global Weighing Model 6221/20t Load Cell

NMI S333A
Rev 5

FIGURE S333A – 3

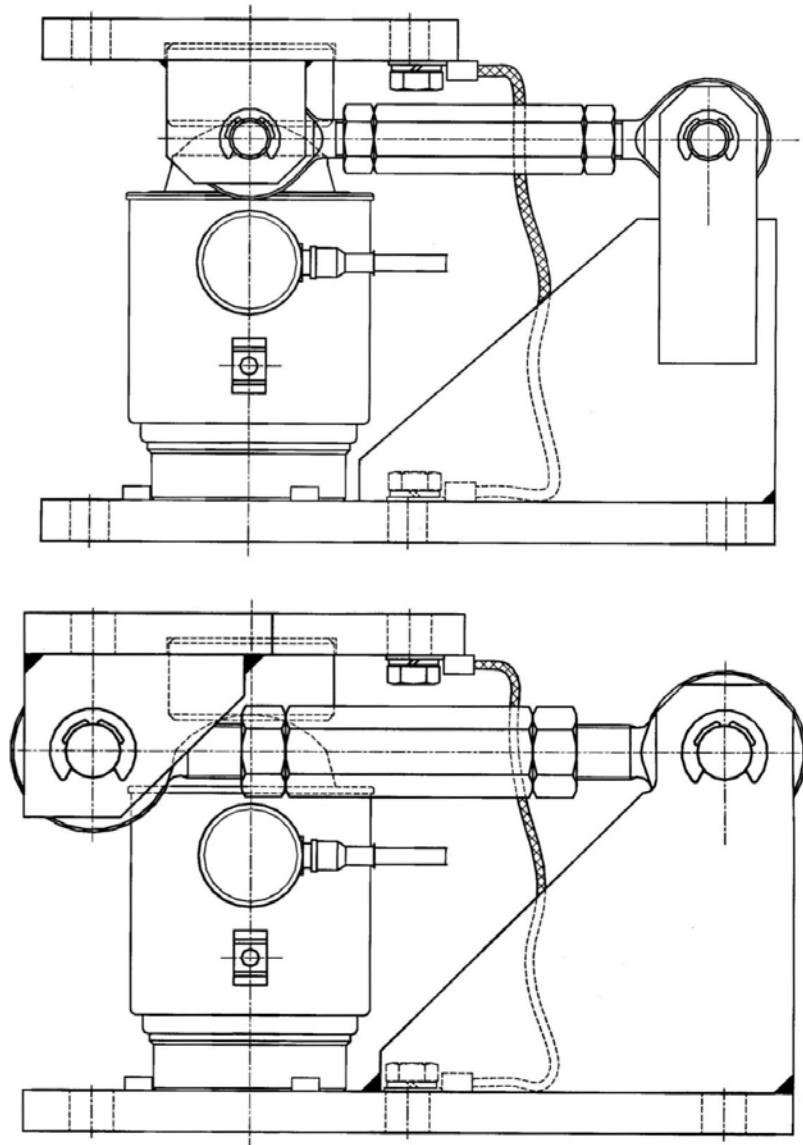

Typical Mounting Methods With Horizontal Constraints

NMI S333A
Rev 5

FIGURE S333A – 4

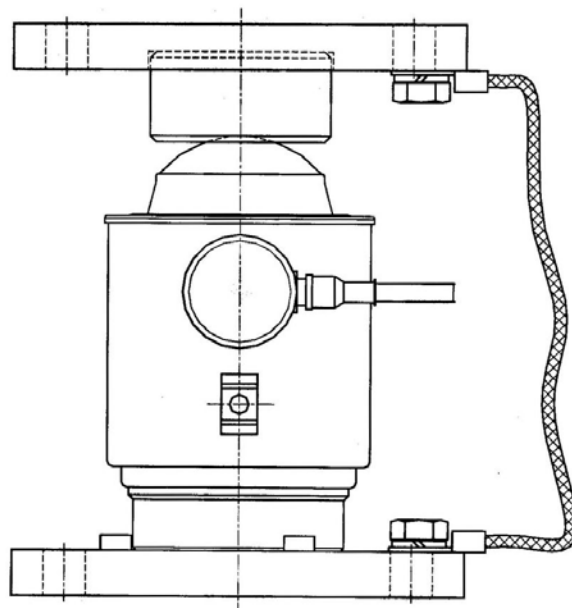
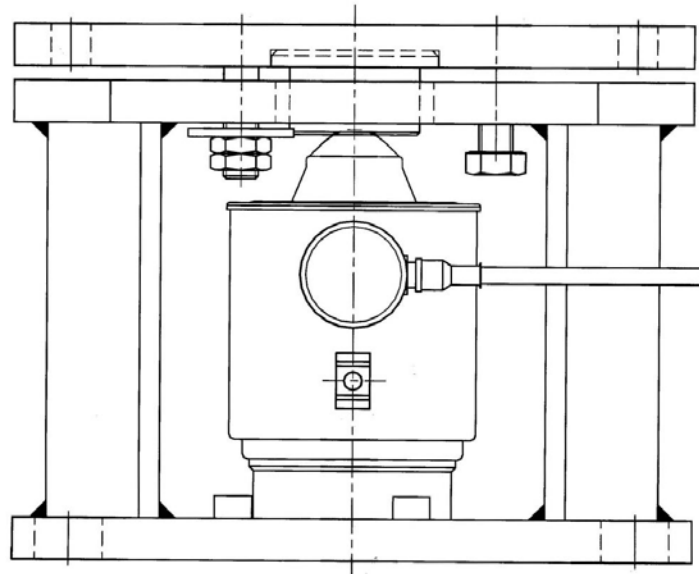

Typical Mounting Methods Without Horizontal Constrainers

~ End of Document ~

Published by
Minebea Intec GmbH | Meiendorfer Strasse 205 A | 22145 Hamburg, Germany
Phone: +49.40.67960.303 | Email: info@minebea-intec.com
www.minebea-intec.com

