

**Installation Manual**

**Pendeo® Process-Digital Precision Compression Load Cell PR 6204B**



## **Foreword**

### **Must be followed!**

Any information in this document is subject to change without notice and does not represent a commitment on the part of Minebea Intec unless legally prescribed. This product should only be operated/installed by trained and qualified personnel. In correspondence concerning this product, the type, name, and release number/serial number as well as all license numbers relating to the product have to be cited.

### **Note**

This document is partially protected by copyright. It may not be changed or copied, and it may not be used without purchasing or written permission from the copyright owner (Minebea Intec). The use of this product constitutes acceptance by you of the abovementioned provisions.

## Table of contents

<b>1</b>	<b>Introduction</b>	<b>3</b>
1.1	Read the manual	3
1.2	This is what operating instructions look like	3
1.3	This is what lists look like	3
1.4	This is what menu items and softkeys look like	3
1.5	This is what the safety instructions look like	3
1.6	Hotline	4
<b>2</b>	<b>Safety instructions</b>	<b>5</b>
2.1	General notes	5
2.2	Intended use	5
2.3	Initial inspection	5
2.4	Before operational startup	5
<b>3</b>	<b>Recommendations for installation</b>	<b>6</b>
3.1	Load cell and constrainer arrangement	6
3.2	Location of load cells and pivots	7
3.3	Additional lift-off protection	8
3.4	Selecting maximum capacity	8
<b>4</b>	<b>Specifications</b>	<b>9</b>
4.1	Equipment supplied with the load cell	9
4.2	General information	10
4.3	Possible marking of the load cell for the Ex area	11
4.4	Dimensions	12
4.5	Ordering information	12
4.6	Technical data	13
<b>5</b>	<b>Installation</b>	<b>15</b>
5.1	Safety instructions	15
5.2	Aligning the load cell	16
5.3	Installation of the upper load disc for max. capacity of 2...50 t	17
<b>6</b>	<b>Connection</b>	<b>18</b>
6.1	General information	18
6.2	Load cell	18
6.2.1	Load cell cable	19
6.2.2	Lightning protection	19
6.3	Cable junction boxes	19
6.4	Power supply	20
6.5	Data and supply cables	20
6.6	Cable connections	20

6.7	Equipotential bonding conductor.....	23
<b>7</b>	<b>Preparing for calibration.....</b>	<b>24</b>
7.1	General notes .....	24
7.2	Mechanical height adaptation.....	24
<b>8</b>	<b>Troubleshooting .....</b>	<b>25</b>
8.1	General Notes.....	25
8.2	Visual inspection.....	25
8.3	Metrological controls .....	25
8.3.1	Checking the screen connection.....	25
8.3.2	Insulation test of power supply .....	25
<b>9</b>	<b>Maintenance/repairs/cleaning.....</b>	<b>26</b>
9.1	Maintenance.....	26
9.2	Repairs.....	26
9.3	Cleaning .....	26
<b>10</b>	<b>Disposal .....</b>	<b>27</b>
<b>11</b>	<b>Spare parts and accessories .....</b>	<b>28</b>
11.1	Replacement parts .....	28
11.2	Accessories .....	28
11.2.1	Mounting kits.....	28
11.2.2	Load discs.....	29
11.2.3	Data and supply cables .....	29
11.2.4	Cable junction boxes .....	29
11.2.5	Power adapter .....	29
<b>12</b>	<b>Certificates .....</b>	<b>30</b>
12.1	MIN22ATEX005X.....	31
12.2	MIN22UKEX003X .....	33
12.3	MEU23002.....	35
12.4	R60/2017-A-NL1-23.01.....	41
12.5	TC12542.....	44
12.6	ER12542.....	49

# 1 Introduction

## 1.1 Read the manual

- Please read this manual carefully and completely before using the product.
- This manual is part of the product. Keep it in a safe and easily accessible location.

## 1.2 This is what operating instructions look like

1. - n. are placed before steps that must be done in sequence.
  - ▶ is placed before a step.
  - ▷ describes the result of a step.

## 1.3 This is what lists look like

- indicates an item in a list.

## 1.4 This is what menu items and softkeys look like

[ ] frame menu items and softkeys.

**Example:**

[Start]- [Applications]- [Excel]

## 1.5 This is what the safety instructions look like

Signal words indicate the severity of the danger involved when measures for preventing hazards are not followed.

### **DANGER**

#### **Warning of personal injury**

DANGER indicates death or severe, irreversible personal injury which will occur if the corresponding safety measures are not observed.

- ▶ Take the corresponding safety precautions.

### **WARNING**

#### **Warning of hazardous area and/or personal injury**

WARNING indicates that death or severe, irreversible injury may occur if appropriate safety measures are not observed.

- ▶ Take the corresponding safety precautions.

### **CAUTION**

#### **Warning of personal injury.**

CAUTION indicates that minor, reversible injury may occur if appropriate safety measures are not observed.

- ▶ Take the corresponding safety precautions.

**NOTICE****Warning of damage to property and/or the environment.**

NOTICE indicates that damage to property and/or the environment may occur if appropriate safety measures are not observed.

- ▶ Take the corresponding safety precautions.
- 

**Note:**

User tips, useful information, and notes.

---

## 1.6 Hotline

Phone: +49.40.67960.444

Fax: +49.40.67960.474

eMail: [help@minebea-intec.com](mailto:help@minebea-intec.com)

## 2 Safety instructions

### 2.1 General notes

#### NOTICE

**Warning of damage to property and/or the environment.**

The product was in perfect condition with regard to safety features when it left the factory.

- ▶ To maintain this condition and to ensure safe operation, the user must follow the instructions and observe the warnings in this manual.

### 2.2 Intended use

The load cell PR 6204B has been designed especially for weighing silos and process vessels.

The load cell PR 6204B may only be used as intended for weighing tasks.

The dimensions of all mounting and structural components must be calculated so that sufficient overload capacity is ensured for all loads which may occur while taking the relevant standards into account. In particular, upright weighing objects must be safeguarded against the weighing installation turning over or being shifted, thus eliminating danger to people, animals, or goods even in the case of a break in a load cell or mounting element.

Installation and repair work must only be carried out by expert/qualified personnel.

The load cell reflects the state of the art. The manufacturer does not accept any liability for damage caused by third-party system components or due to incorrect use of the product.

### 2.3 Initial inspection

Check the contents of the consignment for completeness. Check the contents visually to determine whether any damage has occurred during transport. If there are grounds for rejection of the goods, a claim must be filed with the carrier immediately. The Minebea Intec sales or service organization must also be notified.

### 2.4 Before operational startup

#### NOTICE

**Perform visual inspection.**

- ▶ Before operational startup as well as after storage or transport, inspect the load cell visually for signs of mechanical damage.

### 3 Recommendations for installation

#### 3.1 Load cell and constrainer arrangement

Examples:

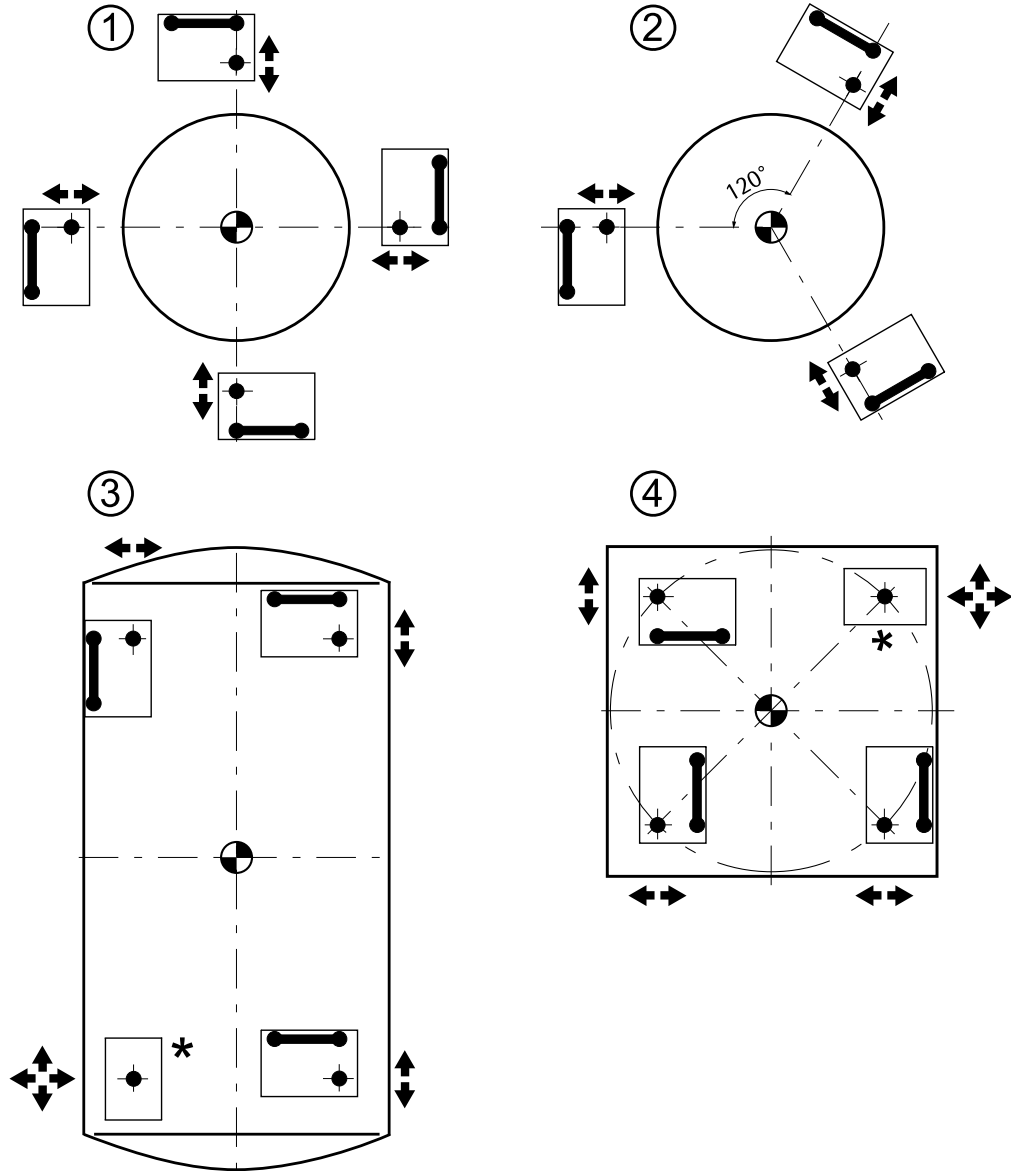

**Key**

*	Do not constrain this position.
	Constrainer
	Load application
	Possible direction of movement

- The supporting structure of the scale (i.e. the load cell support) and the vessel must be stable enough to withstand the specified loads, be horizontal (water level!) and flat.
- Vessels should preferably be supported by 3 load cells, platforms by 4 or 6 load cells (see figure).
- Transverse and/or horizontal forces and torques exceeding the permissible limits are disturbances which can generate measuring errors and, in the worst case, may damage the load cell.
- If the object to be measured is constrained properly, damage and measuring errors can be prevented without affecting the required space for movement in the direction of the measurement.

Consideration should be given to the fact that thermal expansion and contractions may constrict the required space for movement of the object to be weighed and could thereby lead to significant falsification of the measuring results.

Therefore, special attention should be paid to the design, arrangement, and condition of the constrainers.

### 3.2 Location of load cells and pivots

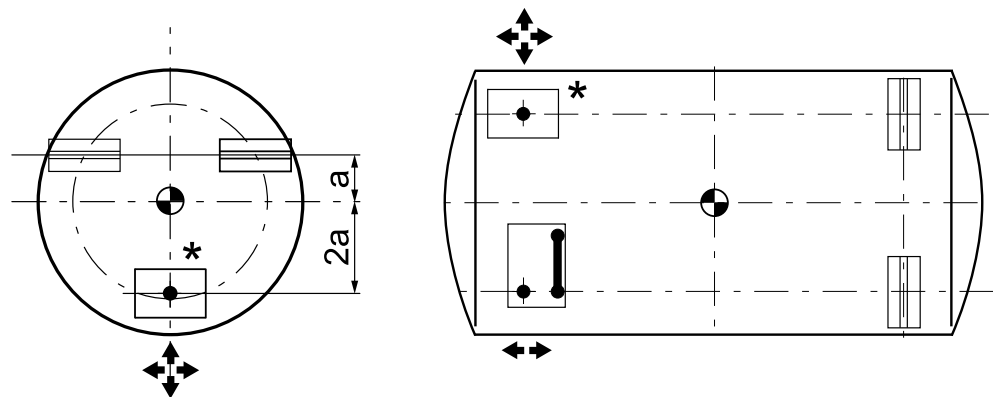

#### Key

	Pivot PR 6101
*	Do not constrain this position.
	Constrainer
	Load application
	Possible direction of movement

### 3.3 Additional lift-off protection

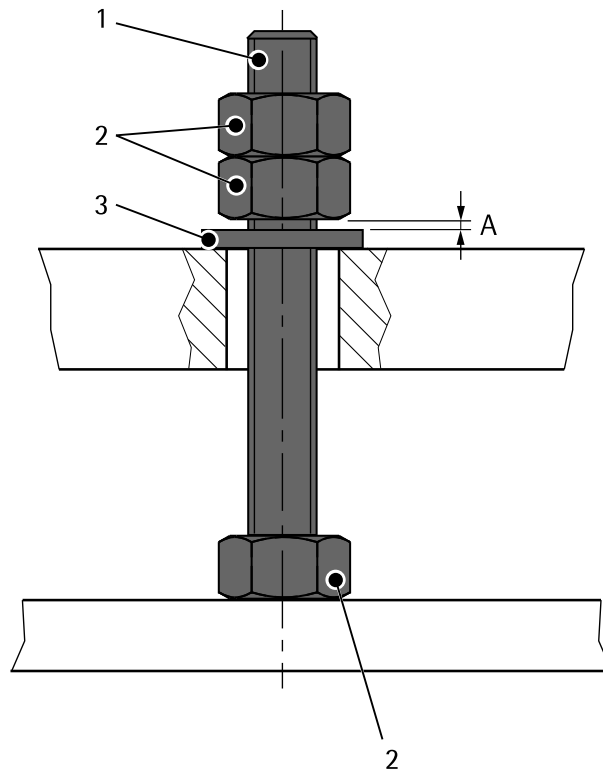

For safety reasons, a lift-off protection has to be generally provided on vessels. This can be constructed separately or additionally installed in the mounting kit (see Chapter [11.2.1](#)).

For this purpose, the simplest version requires the following components:

- 1x threaded bar (1)
- 3x nut (2)
- 1x washer (3)

#### Assembly:

- Mount the threaded bar (1) so that it has sufficient free moving space in the drill hole.
- Lock the nuts (2) so that there is a remaining distance  $A^*$  from the washer (3).

$$* A = 2 \text{ mm}$$

This distance is essential to avoid force shunts.

### 3.4 Selecting maximum capacity

Forces exceeding the safe load limit  $E_{lim}$  in the measuring direction may change the characteristics of the load cell or damage it.

If the safe load limit  $E_{lim}$  of the load cell can be exceeded, e.g. by falling loads, then mechanical limiting in load direction is strongly recommended.

If the destructive load  $E_d$  of the load cell is exceeded, there is danger of mechanical destruction.

## 4 Specifications

### 4.1 Equipment supplied with the load cell

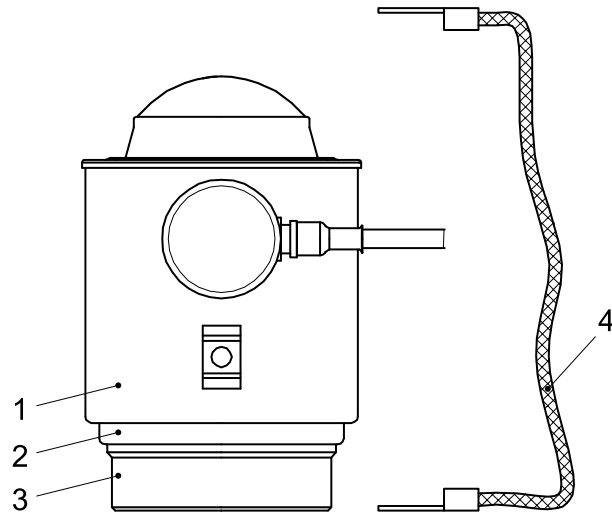

No.	Description
1	Load cell
2	Supporting ring
3	Lower load disc
4	Flexible copper strap
Positions not shown:	
5	Quick guide
6	Calibration Certificate
7	Only with Ex-load cells: Safety information for Ex-load cells

## 4.2 General information

Restoring force	For each mm of displacement that the top of the load cell is shifted from the vertical axis, a horizontal restoring force is generated: $E_{\max} \leq 10 \text{ t}$ : 0.65% of the load resting vertically on the load cell $E_{\max} \geq 20 \text{ t}$ : 1.55% of the load resting vertically on the load cell
Material for load cell housing	Stainless steel 1.4301 acc. to DIN EN 10088-3 (corresponds to AISI 304, B.S. 304S11/S15)
Protection against environmental influences	Hermetically sealed by welding. Filled with inert gas.
Protection classes	in compliance with IEC 529 or DIN EN 60529 <b>IP66/IP68/IP69:</b> Dust-proof and leak-tight against water, with harmful effects when immersed, (1.5 m water depth, 10,000 h) and water jets (high pressure and temperature). <b>Explosion:</b> Suitable for explosion subgroup IIC and IIIC.
Ambient temperature in the Ex area	$-20^\circ\text{C} \leq T_{\text{AMB}} \leq +70^\circ\text{C}$
Cable diameter	5.8 mm
Cable length	Default: $E_{\max} \leq 10 \text{ t}$ : 5 m Default: $E_{\max} > 10 \text{ t}$ : 12 m Max. length: 50 m
Cable gauge	$4 \times 0.35 \text{ mm}^2$
Cable bend radius	$\geq 30 \text{ mm}$ (fixed installation) $\geq 70 \text{ mm}$ (flexible installation)
Cable sheath material	Thermoplastic polyurethane
Cable sheath color	black
Output signal	Serial interface RS-485 bus system, 2-wire
Bus device (load cell)	max. 12
Max. power consumption per load cell	20 mA

### 4.3 Possible marking of the load cell for the Ex area

Zone	Marking	Certificate no.	for
2	II 3G Ex ec IIC T6 Gc	MIN22ATEX005X MIN22UKEX003X	all PR 6204B
22	II 3D Ex tc IIIC T80°C Dc	MIN22ATEX005X MIN22UKEX003X	all PR 6204B

#### NOTICE

##### Installation in the Ex area

- ▶ For installations in the Ex area, it is imperative to observe the Ex safety instructions in the installation manuals.

#### ⚠ WARNING

##### Warning of hazardous area and/or personal injury

When used in a dust ex zone, the risk of electrostatic charging must be minimized.

- ▶ Dust layers on the load cell >5 mm are not permitted.
- ▶ The load cell must be installed securely.
- ▶ When used in protection class "Ex ec" (non-sparking), a transient protective device must be set to a level that does not exceed 140 % of the peak voltage of 85 V.

## 4.4 Dimensions

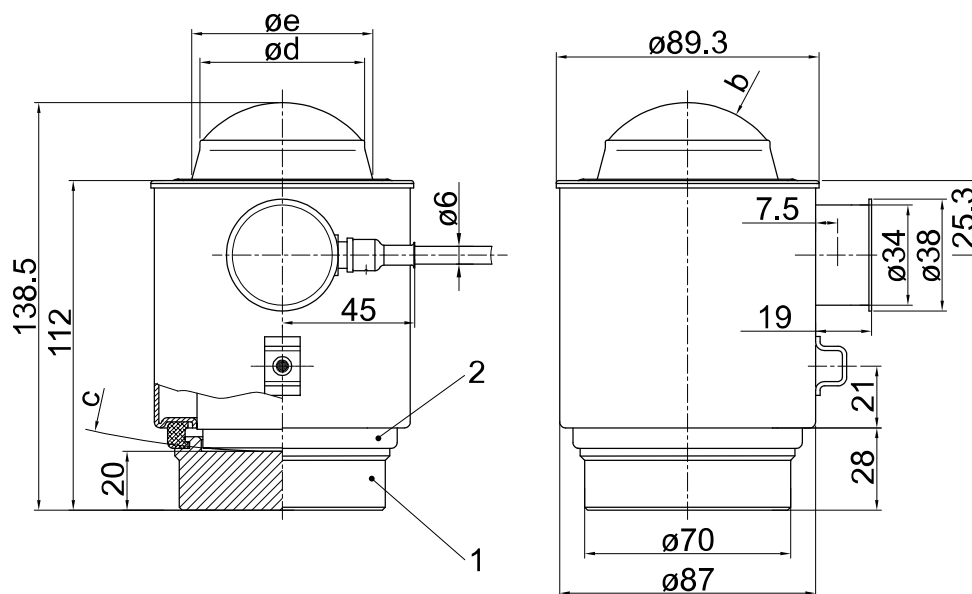

all dimensions in mm

No.	Description
1	Lower load disc
2	Supporting ring

Model	$\varnothing b$ [mm]	$\varnothing c$ [mm]	d [mm]	e [mm]
PR 6204B/2t	15	150	24	32
PR 6204B/5t, ../10t	15	150	34	44
PR 6204B/25t, ../50t	35	220	56	62

## 4.5 Ordering information

Model	Max. capacity $E_{max}$	Type
PR 6204B/2t	2 t	..C3
PR 6204B/5t	5 t	..C3
PR 6204B/10t	10 t	..C3
PR 6204B/25t	25 t	..C3/C6
PR 6204B/50t	50 t	..C3/C6

## 4.6 Technical data

Designation	Description	Abbr.	C3	C6	Unit
Accuracy class			0.0125	0.008	% $E_{max}$
Minimum preload (Dead load)	lowest limit of specified measuring range	$E_{min}$	0		% $E_{max}$
Maximum capacity	highest limit of specified measuring range	$E_{max}$	See Chapter <a href="#">4.5</a>		
Limit load	Highest load without irreversible damage	$E_{lim}$			
	for $E_{max} = 2\text{ t}, 5\text{ t}, 10\text{ t}$	$E_{lim}$	150	...	% $E_{max}$
	for $E_{max} = 25\text{ t}, 50\text{ t}$	$E_{lim}$	150		% $E_{max}$
Destructive load	danger of mechanical destruction	$E_d$			
	for $E_{max} = 2\text{ t}, 5\text{ t}, 10\text{ t}$	$E_d$	300	...	% $E_{max}$
	for $E_{max} = 25\text{ t}, 50\text{ t}$	$E_d$	300		% $E_{max}$
Minimum LC verification	minimum load cell scale interval, $v_{min} = E_{max}/Y$	Y	14000	20000	
	for $E_{max} = 2\text{ t}$	Y	10000	...	
Minimum preload-signal recurrence	Recurrence of the minimum preload signal ( $DR = \frac{1}{2} \times E_{max}/Z$ )	Z	3000	8000	
Rated output	relative output at maximum capacity	$C_n$	standardized to $E_{max}$ (t)		
Tolerance on rated output	permissible deviation from rated output $C_n$	$d_c$	<0.07		% $C_n$
Zero output signal	load cell output signal under unloaded condition	$S_{min}$	$0 \pm 0.7$		% $C_n$
Repeatability	max. change in load cell output for repeated loading	$\epsilon_R$	<0.005		% $C_n$
Creep	max. change of output signal at $E_{max}$ during 30 minutes	$d_{cr}$	<0.0125	<0.008	% $C_n$
Non-linearity <sup>1)</sup>	Deviation from the best straight lines through zero	$d_{Lin}$	<0.01	<0.01	% $C_n$
Hysteresis <sup>1)</sup>	max. difference in LC output between loading and unloading	$d_{hy}$	<0.0125	<0.008	% $C_n$
Temperature coefficient of the minimum preload signal	max. change of $S_{min}$ in $B_T$	$TK_{S_{min}}$	<0.01	<0.007	% $C_n/10\text{ K}$
Temperature effect on $C^1)$	max. change of $C$ in $B_T$	$TK_C$	<0.01	<0.005	% $C_n/10\text{ K}$
Insulation impedance	between internal circuit and housing, $U_{DC} = 50\text{ V}$	$R_{IS}$	>1000		$M\Omega$

Designation	Description	Abbr.	C3	C6	Unit
Recommended supply voltage	to hold the specified performance	B <sub>U</sub>	12...28		V
Nominal ambient-temp. range	to hold the specified performance	B <sub>T</sub>	-10...+40		°C
Usable ambient temp. range	permissible for continuous operation without damage	B <sub>Tu</sub>	-30...+70		°C
Storage temperature range	without electrical and mechanical stress	B <sub>Ti</sub>	-40...+95		°C
Permissible eccentricity	permissible displacement from nominal load line at the head of the load cell	S <sub>ex</sub>			
	for E <sub>max</sub> = 2 t, 5 t, 10 t	S <sub>ex</sub>	10	...	mm
	for E <sub>max</sub> = 25 t, 50 t	S <sub>ex</sub>	5		mm
Vibration resistance	Resistance against oscillations (IEC 60068-2-6 Fc)		20 g, 100 h, 10...150 Hz		
Barometric pressure influence	influence of barometric pressure on output	PK <sub>Smin</sub>			
	for E <sub>max</sub> = 2 t	PK <sub>Smin</sub>	<200	...	g/kPa
	for E <sub>max</sub> = 5 t, 10 t	PK <sub>Smin</sub>	<320	...	g/kPa
	for E <sub>max</sub> = 25 t, 50 t	PK <sub>Smin</sub>	<420		g/kPa
Nominal deflection	max. elastic deformation under maximum capacity	S <sub>nom</sub>			
	for E <sub>max</sub> = 2 t, 5 t, 10 t	S <sub>nom</sub>	<0.5	...	mm
	for E <sub>max</sub> = 25 t	S <sub>nom</sub>	<0.5		mm
	for E <sub>max</sub> = 50 t	S <sub>nom</sub>	<0.8		mm

1) The data for non-linearity (d<sub>Lin</sub>), hysteresis (d<sub>hy</sub>) and temperature effect on C (TK<sub>C</sub>) are typical values.  
For OIML R60 or NTEP approved load cells the sum of these values is within the permissible cumulative error limits.

Definitions acc. to OIML R60

The technical data given are intended solely as a product description and should not be interpreted as guaranteed properties in the legal sense.

## 5 Installation

### 5.1 Safety instructions

#### NOTICE

**Welding or lightning strike current flowing through the cell can damage it.**

All electrical welding on the weighing system must be finished before mounting the load cells.

- ▶ When installing the load cell, immediately bypass the load cell with the flexible copper strap provided for this purpose (included in the equipment supplied, see Chapter 4.1).

During any additional electrical welding work near the load cell:

- Disconnect the load cell cables.
- Bypass the load cell using the flexible copper strap.
- Make sure that the grounding clamp of the welding set is fitted as closely as possible to the welding joint.

The following must be observed during installation:

- Do not lift or transport the load cell by pulling on the cable.
- Avoid shock stress (falling down, hard shocks).
- The load cell must be installed vertically and centrally in the mounting kit.
- Load forces must act in the measuring direction of the load cell.
- The load disc must not be subjected to transverse forces.
- All contact points between load cell and load disc must be adequately greased.  
Load cell grease order no., see Chapter 11.1.

#### NOTICE

**Changes of temperature >15 K/h may influence the measuring accuracy.**

- ▶ Make sure to protect the load cells from direct heating or cooling effects (sun, wind, heat radiation, fan heaters), e.g., heat protection screens or heat protection housings are to be installed if necessary.

#### NOTICE

**Force shunts may cause measuring errors.**

- ▶ All incoming and outgoing lines (hoses, pipes, cables) must be coupled to the measured object as flexibly as possible.

## 5.2 Aligning the load cell

Load cells must be installed so that their axis is vertical when not in use.

Even minor deviations can lead to unexpected effects.

When the PR 6001/.. mounting kit is used, the correct position of the adjustment notches ensures that it is positioned properly (vertical and not jammed or wedged).

If the load cell is installed on a slant accidentally, then this changes its characteristic value.

All load cells must be carefully aligned.

To make it easier to get an exact vertical alignment, the PR 6001/.. mounting kit is equipped with a mounting aid.

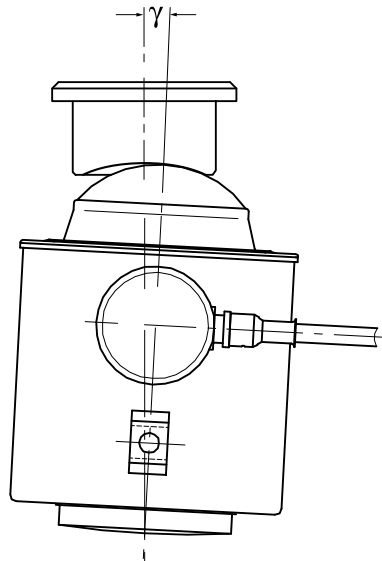

$$\gamma \leq 1^\circ$$

The maximum permissible inclination must be strictly observed so that measuring accuracy is not adversely overly affected (see figure).

---

**Note:**

The material properties and the shape of the load cells and load discs are perfectly matched to one another. Always use load discs from Minebea Intec, see also Chapter [11.2.2](#).

---

**Procedure:**

- Lift up weighing object approx. 5 mm using a jack-up or corresponding lifting device.
  - Correct the position of the load cell using the supporting ring on the lower load disc.
  - Set the weighing object back down on the mounting kit and make sure that the load cell is vertical and the load cell dome is positioned in the exact center of the load disc.
  - Check to ensure that the adjustment notches are in the correct position.
- 

**Note:**

Further installation instructions can be found in the manuals of the respective mounting kits.

---

### 5.3 Installation of the upper load disc for max. capacity of 2...50 t

---

**Note:**

The figures below shows a schematic of load cell and upper load disc.

---

---

**Small load cell radius (15 mm)**

$E_{\max} = 2...10 \text{ t}$

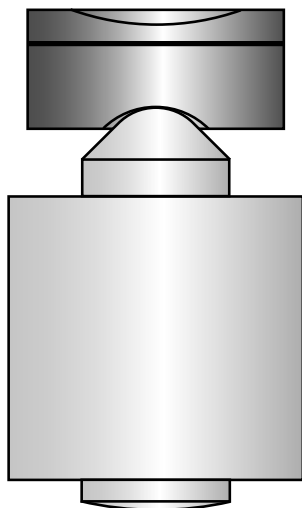

---

**Large load cell radius (35 mm)**

$E_{\max} = 25...50 \text{ t}$

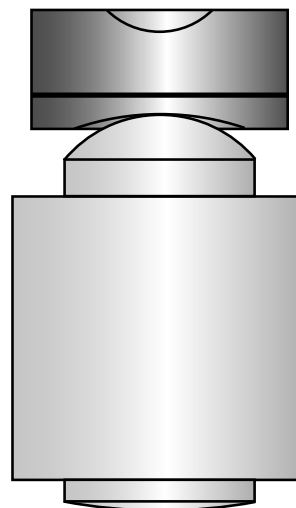
**Note:**

Load discs made of stainless steel are marked with a double groove.

Further installation instructions can be found in the manuals of the respective mounting kits.

---

## 6 Connection

### 6.1 General information

- Protect the cable ends against contamination. Moisture must not get into the open end of the cable.
- The digital load cell cable may be shortened.
- The screen of the load cell cable is connected to the load cell housing. A PR 6024/68S type cable junction box must be used.
- Keep the load cell cables away from power cables.
- The distance between measurement cables and power cables and/or components under high voltage should be at least 1 m (reference value).
- We recommend laying the load cell cables in separate cable trays or armored steel pipes.
- Power cables should be crossed at right angles while taking into account the minimum distance of 1 m (reference value).

### 6.2 Load cell

#### Color Code

rd	=	red
gn	=	green
bu	=	blue
gy	=	gray

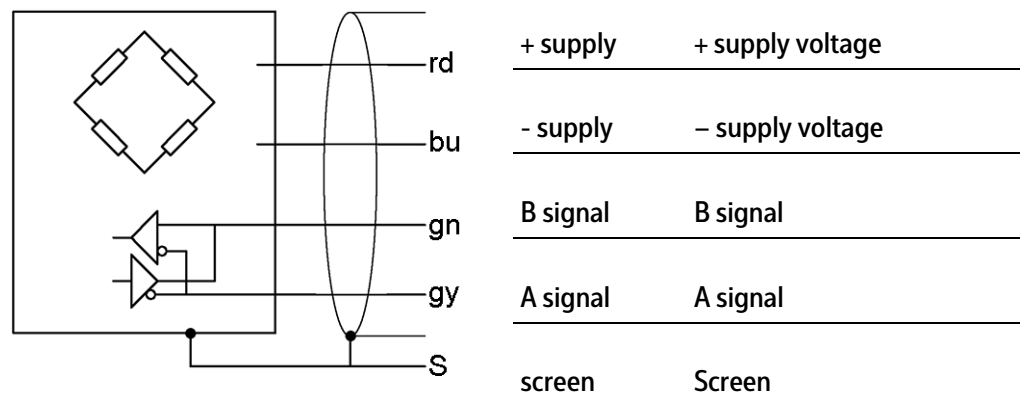

#### NOTICE

**The cable screen is connected to the load cell housing.**

- ▶ Make sure to use the PR 6024/68S cable junction box (see Chapter [11.2.4](#)).
- ▶ The cable junction box is still required even if only 1 load cell is being connected.

**NOTICE**

**The digital load cell will be destroyed if connected incorrectly.**

- ▶ Ensure that the load cells are connected in accordance with the connection plans in Chapter [6.6](#).
- ▶ See also the safety instructions in Chapter [12](#).

### 6.2.1 Load cell cable

The load cell cables are inseparably connected to the load cells in the factory.

The digital load cell cable may be shortened.

The special sheathing material ensures extremely long service life even under difficult operating conditions.

However, despite the robust nature of the materials used, the cable should be protected from excessive chemical and mechanical stresses. Preventing water from penetrating the end of the cable is also important "life insurance" for the system.

### 6.2.2 Lightning protection

To retain the functionality of the load cells even in the case of lightning strikes near the scale, the cable junction box PR 6024/68S must be used.

**NOTICE**

**Additional lightning protection elements in the measuring circuit compromise the high measuring accuracy of the load cells or the lightning protection.**

Always carry out the installation exclusively according to the instructions in order not to void any warranty claims.

- ▶ In particular, the entire installation, including the power supply, must be sufficiently protected against lightning! Simply connecting the protective grounding conductor is not enough!

## 6.3 Cable junction boxes

The cable junction box PR 6024/68S (see Chapter [11.2.4](#)) must be used to connect the load cells. These boxes have extremely high-quality screw terminals with high contact security and long-term stability along with a special conduit as well as integrated elements for transient overvoltage protection.

The special valve with a GoreTech semi-permeable membrane ensures permanent pressure compensation during fluctuating temperatures and weather conditions, and effectively prevents water from penetrating.

**NOTICE**

**Defective cable junction box due to penetration of water.**

- ▶ Special valve must not be removed.

## 6.4 Power supply

The power supply unit PR 6024/62S (see Chapter [11.2.5](#)) must be used for the power supply of the load cells.

## 6.5 Data and supply cables

The PR 6124/xxD data cable must be used to connect the PR 6024/68S cable junction box to the device, max. length: 300 m.

The PR 6124/xxP power cable must be used to connect the PR 6024/62S power supply to the PR 6024/68S cable junction box, max. length: 200 m

---

### Note:

For order numbers, see Chapter [11.2.3](#).

---

## 6.6 Cable connections

---

### Note:

All components are only shown schematically.

---

### Color Code

rd	=	red
gn	=	green
bu	=	blue
gy	=	gray

---

### NOTICE

**The functionality of the load cells is also threatened by lightning strikes near the scale.**

- ▶ Make sure to use cable junction box PR 6024/68S (see Chapter [11.2.4](#)).
  - ▶ For more information, see the cable junction box installation manual.
- 

### NOTICE

#### Possible destruction of the load cells

The digital load cell will be destroyed if connected incorrectly.

- ▶ Make the connection as shown in the illustrations.
-

**Connection example: Connecting 8 load cells to the PR 5510/04 interface card**

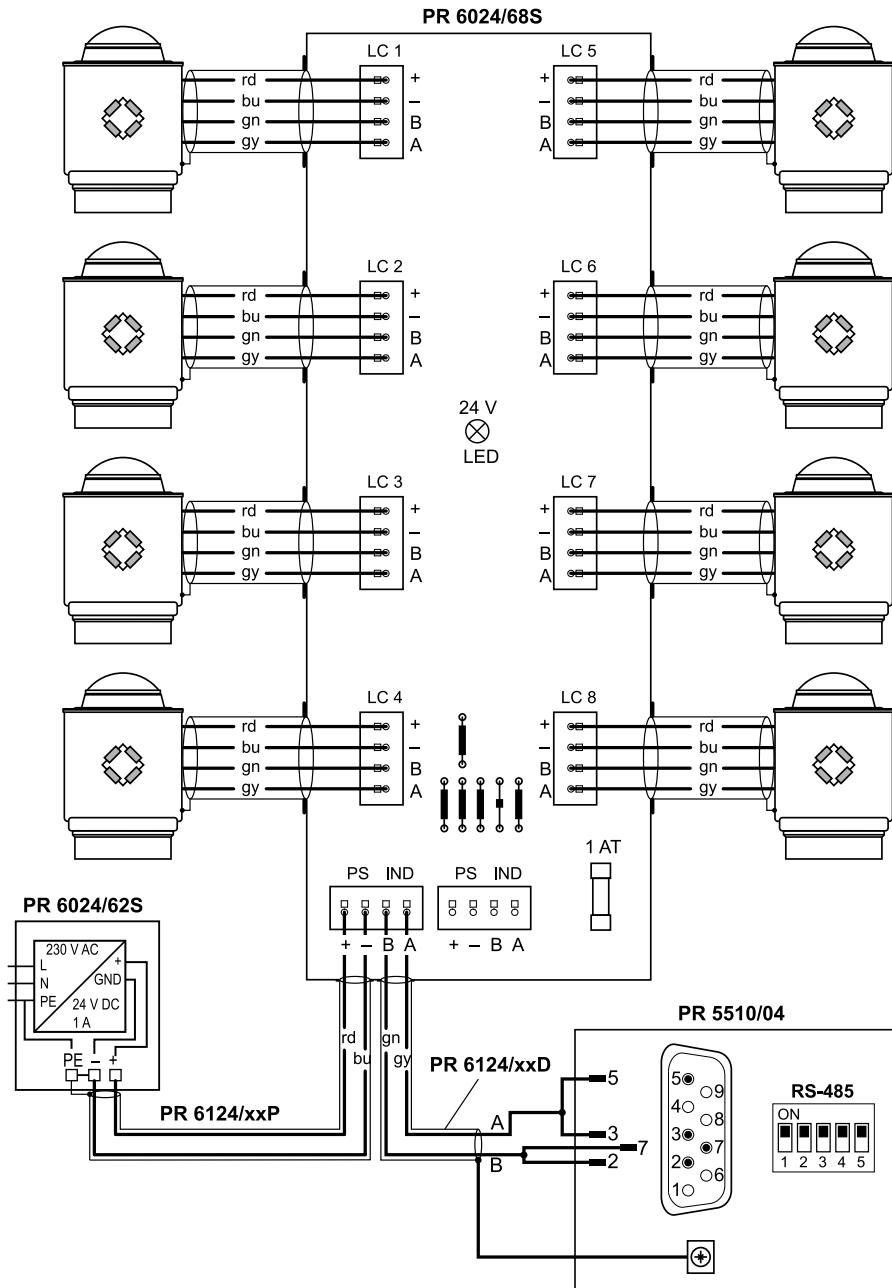

**Connection example: Connecting 12 load cells to the PR 5510/04 interface card**

**NOTICE**

The power supply unit is approved to power up to 8 digital load cells in the explosion-prone zone.

- ▶ Connecting 12 digital load cells in the explosion-prone zones is not allowed.

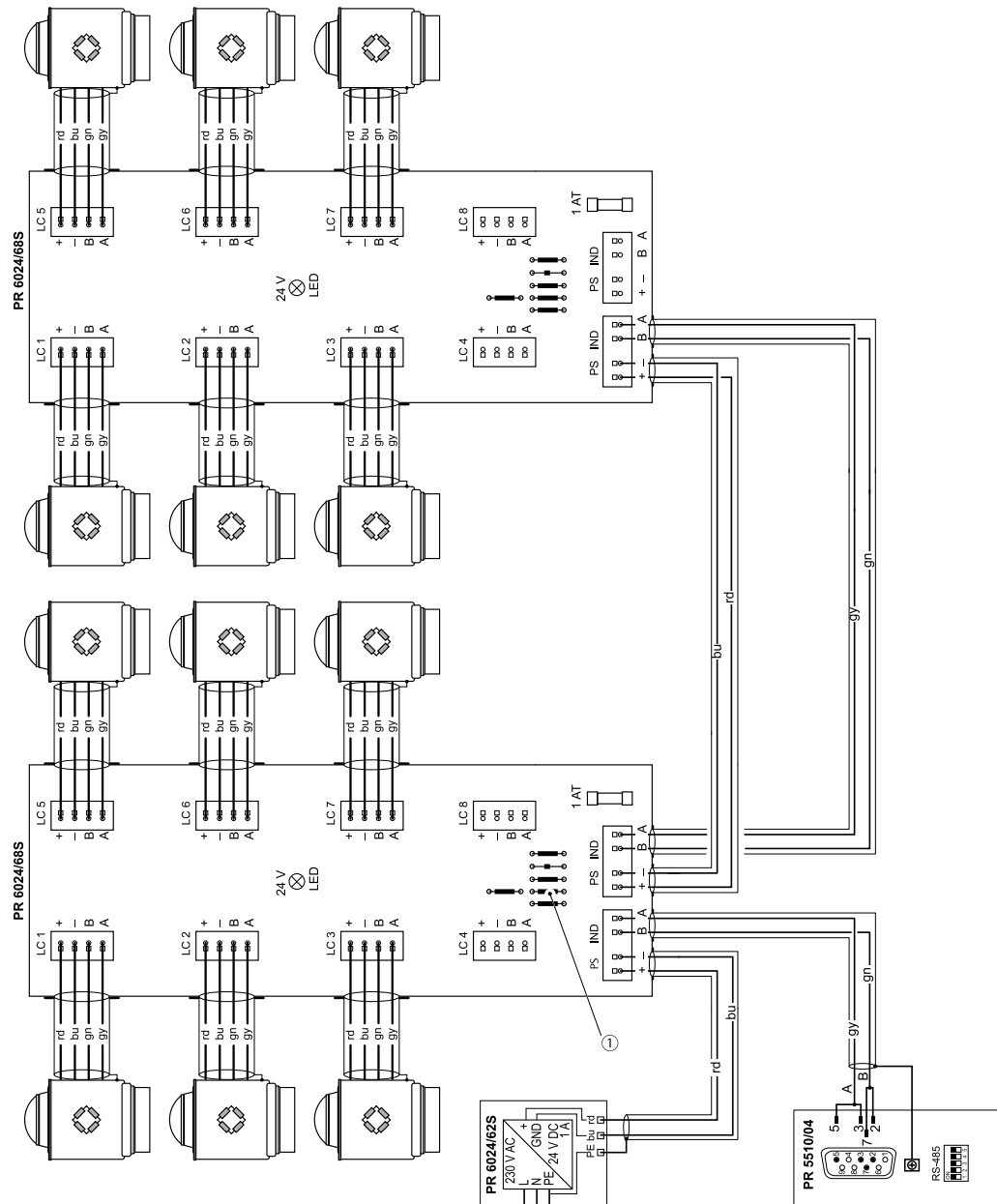

① Remove the terminating resistor

## 6.7 Equipotential bonding conductor

### NOTICE

It is especially important that the ground is connected correctly to the components and the cable junction box.

You must also ground the device separately and ensure the power supply is properly shielded against the effects of lightning. Simply connecting the protective grounding conductor is not enough!

- ▶ If the installation is not carried out according to our instructions, this voids the warranty. In particular, the entire installation, including the power supply, must be sufficiently protected against lightning.
- ▶ For further information, see the installation manual relating to the cable junction boxes.

### Connection example

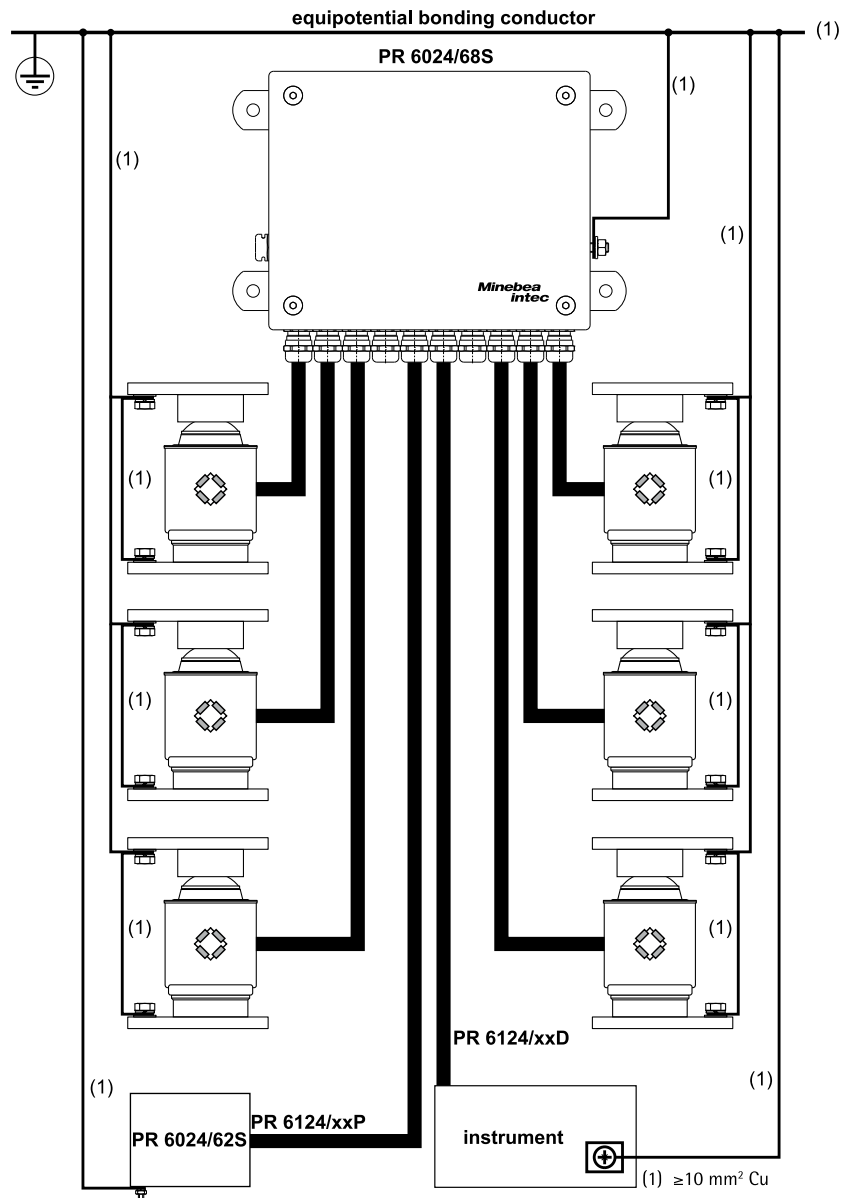

## 7 Preparing for calibration

### 7.1 General notes

The digital load cells PR 6204B are characterized by the fact that the output signals for each individual load cell come factory-adjusted. All cells provide the same output signal with an equally-divided corner load (e.g. dead load).

In many cases, this considerably minimizes the adjustment effort with regards to the scale because the software will handle the adjustment (see Chapter "Software Corner Correction" in the instrument manual of the indicator).

---

**Note:**

For calibration of the measuring system, please refer to the manual of the corresponding indicator.

---

### 7.2 Mechanical height adaptation

To distribute the load over the load cells as evenly as possible, height adaptation is required in systems with more than 3 load cells prior to calibration.

**Procedure:**

1. Place the dead load (e.g. empty vessel) onto the load cells of the scale structure.
2. Lift weighing system directly adjacent to the load cell with the lowest dead load indication.
3. Place a shim (0.5...2 mm thick) between install plate and scale construction.
4. Load the vessel feet, one after the other.
  - ▷ The same value must always be read-off on the connected device.
5. If this is not the case; first carefully check the vertical alignment of the load cells and ensure that the pressure pieces are seated centrally.

If the signal deviations cannot be resolved by carefully leveling the scale, the software must be calibrated; see the device manual for the evaluation device.

Due to the precision calibration of the cells in production, here only very small corrections should be necessary.

---

**Note:**

An excessive deviation almost always means that the scale is tilted or indicates force shunts or a defective load cell.

---

## 8 Troubleshooting

### 8.1 General Notes

The following hints will enable a technician to do an initial diagnostic or help in case of incorrect or non-reproducible weighing results after commissioning and calibration.

### 8.2 Visual inspection

Component	Possible errors
Weighing object	Are all pipes, hoses and cables free from shunt forces? Are the connections pliable and connected horizontally? Are elements with a solid connection to the scale in direct contact with the surroundings? Has friction developed between the weighing object and its surroundings (e.g. dusty openings, ...)?
Cable junction box	Has moisture intruded? Do all soldering and screw connections have secure contact?
Mains supply	Has moisture intruded? Is the LED lit? If the LED is not lit, both fuses must be checked.
Data and supply cables	Is the sheath damaged? Has moisture intruded?
Mounting kit	Is the lift-off protection in contact with the scale? Are the constrainers stuck?
Load cell	Is the load cell vertical? Is the adjustment chamber cover damaged? Is the sheath of the load cell cable damaged? Has moisture penetrated into the load cell cable?

### 8.3 Metrological controls

#### 8.3.1 Checking the screen connection

- Insulate the load cell cores.

Screen – housing: 0 Ω

#### 8.3.2 Insulation test of power supply

- Connect data lines A and B (gray and green) to the screen.
- Bring the supply lines (red and blue) together and then perform the insulation measurement against screen.

Max. test voltage: Standard version  $U_{DC} = 50 \text{ V}$

Impedance: >1000 MΩ

## 9 Maintenance/repairs/cleaning

### 9.1 Maintenance

The load cell PR 6204B is maintenance-free.

Load cell grease must be applied to the contact surfaces between the load cell and load discs. Load cell grease order number, see Chapter [11.1](#).

The load cell can be extensively sprayed with off-shore all-weather protection spray in aggressive environments.

#### Load cell grease specification

- good water/media resistance
- good corrosion protection properties
- good oxidization and aging stability
- good temperature resistance
- and, where appropriate, good compatibility with foodstuffs

The requirements referred to apply when taking into account the specific operating/usage conditions.

The grease also serves as protection against wear (low friction).

### 9.2 Repairs

The load cell PR 6204B is designed to be as robust as possible for the required measuring accuracy and is highly reliable.

Should an electrical or mechanical defect nevertheless occur, the load cell must be replaced.

Load cell repair is not possible.

### 9.3 Cleaning

Dirt on the load cell and movable parts of the scale must be cleaned as quickly as possible

- if it influences weighing, or
- if it is corrosive to the cell or cable material.

#### **NOTICE**

**Some cleaning agents may not be compatible with the load cell material.**

- ▶ When using cleaning agents, ensure that their compatibility with the load cell material has been tested and approved (see Chapter [4.2](#)).

## 10 Disposal

Our products and their packaging should not be disposed of in municipal waste (e.g. garbage can for recyclable packaging, garbage can for paper packaging, etc.). They can either be recycled by the customer themselves, providing this complies with requirements set out by electrical or electronic waste or packaging waste laws, or sent back to Minebea Intec at a charge.

This option of returning the product is intended to provide proper recycling or reuse in a manner that is collected separately from municipal waste.

Before disposing of or scrapping the old products, any single-use or rechargeable batteries should be removed and taken to a suitable collection point. The type of battery used is specified in the technical data.

Please see our General Terms and Conditions for further information.

Service addresses for repair acceptance and collection points can be found on the product information enclosed with the product as well as on our website ([www.minebea-intec.com](http://www.minebea-intec.com)).

Should you have any further questions, please contact your local service representative or our service center.

Minebea Intec GmbH

Repair center

Meiendorfer Strasse 205 A

22145 Hamburg, Germany

Phone: +49.40.67960.333

[service.HH@minebea-intec.com](mailto:service.HH@minebea-intec.com)

We reserve the right not to accept products that are contaminated with hazardous substances (ABC contamination).

## 11 Spare parts and accessories

### 11.1 Replacement parts

No.	Description	Max. capacity	Order no.
1	Flexible copper strap, 400 mm long		5312 321 28057
2	Lower load disc with supporting ring	2...10 t	5322 693 91416
3	Lower load disc with supporting ring	25 t, 50 t	5312 693 98148
4	Supporting ring, default	500 kg...50 t	5312 532 58017
5	Supporting ring, food-safe	500 kg...50 t	5322 532 70317
6	Load cell grease 4x 5 g		5312 390 12001

### 11.2 Accessories

#### 11.2.1 Mounting kits

To install the load cell, the following mounting kits / pivots are recommended:

No.	Description	Max. capacity	Order no.
1	Mounting kit PR 6001/00N	500 kg–10 t	9405 360 01001
2	Mounting kit PR 6001/00S	500 kg–10 t	9405 360 01002
3	Mounting kit PR 6001/01N	20–50 t	9405 360 01011
4	Mounting kit PR 6001/01S	20–50 t	9405 360 01012
5	Mounting kit PR 6145/00N incl. lower load disc with supporting ring PR 6143/54S @ 20–50 t	500 kg–10 t	9405 361 45001
6	Mounting kit PR 6145/00S incl. lower load disc with supporting ring PR 6143/54S @ 20–50 t	500 kg–10 t	9405 361 45002
7	Pivot PR 6101/53N	5 t	9405 561 01531
8	Pivot PR 6101/53S	5 t	9405 561 01532
9	Pivot PR 6101/24N	20 t	9405 561 01241
10	Pivot PR 6101/24S	20 t	9405 561 01242
11	Pivot PR 6101/54N	50 t	9405 561 01541
12	Pivot PR 6101/54S	50 t	9405 561 01542

N = steel zinc plated, passivated and sealed (RoHS-compliant)

S = stainless steel

No.	Description	Perm. horizontal force	Order no.
13	Maxi FLEXLOCK PR 6001/10N	≤25 kN	9405 360 01101
14	Maxi FLEXLOCK PR 6001/10S	≤25 kN	9405 360 01102
15	Maxi FLEXLOCK PR 6001/11N	≤25 kN	9405 360 01111

No.	Description	Perm. horizontal force	Order no.
16	Maxi FLEXLOCK PR 6001/11S	≤25 kN	9405 360 01112
17	Mini FLEXLOCK PR 6143/00N	≤25 kN	9405 361 43001
18	Mini FLEXLOCK PR 6143/00S	≤25 kN	9405 361 43002
19	Constrainer PR 6143/80	≤2 kN	9405 361 43801
20	Constrainer PR 6143/83	≤20 kN	9405 361 43831

N = steel zinc plated, passivated and sealed (RoHS-compliant)

S = stainless steel

### 11.2.2 Load discs

To install the load cell, the following load discs are recommended:

No.	Description	Max. capacity	Order no.
1	Upper load disc, standard PR 6143/50N	500 kg–50 t	9405 361 43501
2	Upper load disc, PR 6143/50S	500 kg–50 t	9405 361 43502
3	Lower load disc with supporting ring PR 6143/24S	500 kg–10 t	9405 361 43242
4	Lower load disc with supporting ring PR 6143/54S	20–50 t	9405 361 43542

N = steel zinc plated, passivated and sealed (RoHS-compliant)

S = stainless steel

### 11.2.3 Data and supply cables

The following data and supply cables are recommended:

No.	Designation	Order no.
1	Data cable PR 6124/..D	9405 361 24xx3
2	Supply cable PR 6124/..P	9405 361 24xx4

### 11.2.4 Cable junction boxes

Using the following cable junction box is required:

No.	Description	Order no.
1	PR 6024/68S (1.4404, 1–8 load cells, IP66, IP68, IP69)	9405 360 21684

### 11.2.5 Power adapter





The power supply unit is required for the voltage supply:

No.	Designation	Order no.
1	PR 6024/62S (1.4301, IP 66, IP68, IP69)	9405 360 24624

## 12 Certificates

<b>Ser. no.</b>	<b>Description</b>	<b>Document no.</b>	<b>see Chapter</b>
1	Manufacturer's Certificate	MIN22ATEX005X	<a href="#">12.1</a>
2	Manufacturer's Certificate UKCA	MIN22UKEX003X	<a href="#">12.2</a>
3	EU-Declaration of Conformity	MEU23002	<a href="#">12.3</a>
4	OIML Certificate (NMI)	R60/2017-A-NL1-23.01	<a href="#">12.4</a>
5	Test Certificate (NMI)	TC12542	<a href="#">12.5</a>
6	Evaluation report (NMI)	ER12542	<a href="#">12.6</a>

## 12.1 MIN22ATEX005X

	<b>Herstellerbescheinigung Manufacturer's certificate</b>	
<b>Nummer Number</b>	MIN22ATEX005X	
<b>Hersteller Manufacturer</b>	Minebea Intec GmbH Meiendorfer Straße 205A 22145 Hamburg, Germany	
	erklärt in alleiniger Verantwortung, dass das Produkt <i>declares under sole responsibility that the product</i>	
<b>Geräteart Device type Baureihe Type series</b>	Digital Load Cell PR 6224B, PR 6204B	
	auf das sich diese Bescheinigung bezieht, mit der/den folgenden Norm(en) oder normativen Dokument(en) übereinstimmt (siehe Seite 2) gemäß den Bestimmungen der „Richtlinie 2014/34/EU des Europäischen Parlaments und des Rates vom 26. Februar 2014 zur Harmonisierung der Rechtsvorschriften der Mitgliedstaaten für Geräte und Schutzsysteme zur bestimmungsgemäßen Verwendung in explosionsgefährdeten Bereichen“. Das Produkt wird wie folgt gekennzeichnet: <i>to which this certification relates is in conformity with the following standard(s) or other normative document(s) (see page 2) pursuant to the provisions of the "Directive 2014/34/EU of the European Parliament and of the Council of 26 February 2014 on the harmonisation of the laws of the Member States relating to equipment and protective systems intended for use in potentially explosive atmospheres". This product is labelled as follows:</i>	
<b>Kennzeichnung Marking</b>	II 3G Ex ec IIC T6 Gc II 3D Ex tc IIIC T80°C Dc MIN22ATEX005X	
	Minebea Intec GmbH Hamburg, 03.02.2023	
	 ----- Dr. K. Sommer Managing Director	 ----- Dr. A. Böttger CTO
		 ----- Torben Hiller EX Approval Manager
	Diese Erklärung bescheinigt die Übereinstimmung mit den genannten EU-Richtlinien, ist jedoch keine Zusicherung von Eigenschaften. Bei einer mit uns nicht abgestimmten Änderung des Produktes verliert diese Erklärung ihre Gültigkeit. Die Sicherheitshinweise der zugehörigen Produktdokumentation sind zu beachten. <i>This declaration certifies conformity with the above mentioned EC Directives, but does not guarantee product attributes. Unauthorized product modifications make this declaration invalid. The safety information in the associated product documentation must be observed.</i>	
	1/2 MIN22ATEX005X Rev. 00	



## Herstellerbescheinigung Manufacturer's certificate



Die grundlegenden Sicherheits- und Gesundheitsanforderungen werden erfüllt durch Übereinstimmung mit:  
*Compliance with the Essential Health and Safety Requirements has been assured by compliance with:*

**Normen  
Standards**

**EN IEC 60079-0:2018**

Explosionsgefährdete Bereiche – Teil 0: Geräte – Allgemeine Anforderungen  
*Explosive atmospheres – Part 0: Equipment – General requirements*

**EN IEC 60079-7:2015/A1:2018**

Explosionsgefährdete Bereiche – Teil 7: Geräteschutz durch erhöhte Sicherheit „e“  
*Explosive atmospheres – Part 7: Equipment protection by increased safety "e"*

**EN 60079-31:2014**

Explosionsfähige Atmosphäre – Teil 31: Geräte-Staubexplosionsschutz durch Gehäuse „t“  
*Explosive atmospheres – Part 31: Equipment dust ignition protection by enclosure "t"*

Diese Bescheinigung wurde auf Basis des folgenden Prüfberichts erstellt:  
*This certificate was drawn on the basis of the following test report:*

**Prüfbericht  
Test Report**

**MTR22002**

Minebea Intec GmbH, Hamburg, Germany

**Sicherheitshinweise  
Safety instructions**

65835-790-16

**Umgebungstemperatur  
Ambient temperature**

$-20^{\circ}\text{C} \leq T_{\text{AMB}} \leq +70^{\circ}\text{C}$

**Elektrische Daten  
Electrical Data**

$U_n = 28 \text{ Vdc}$

$I_n = 500 \text{ mA}$

**IP Protection Class**

IP66, IP69

Für dieses Produkt gelten folgende besonderen Bedingungen für den sicheren Gebrauch:  
*For this product the following special conditions for safe use apply:*



**besondere Bedingungen  
special Conditions**

Beachten Sie die Angaben in den Sicherheitshinweisen.  
*Follow the instructions given in the safety instructions.*

Vermeiden Sie elektrostatische Aufladung.  
*Avoid electrostatic charging.*

Die Wägezellen und Kabel müssen fest verlegt werden.  
*The load cells and cables must be laid securely (fixed installation).*

## 12.2 MIN22UKEX003X

<b>UK CA</b>	<b>Manufacturer's certificate</b>	<b>Minebea intec</b> <small>The true measure</small>
<b>Number</b>	MIN22UKEX003X	
<b>Manufacturer</b>	Minebea Intec GmbH Meiendorfer Straße 205A 22145 Hamburg, Germany	
	declares under sole responsibility that the product	
<b>Device type</b>	Digital Load Cell	
<b>Type series</b>	PR 6224B, PR 6204B	
	to which this certification relates is in conformity with the following standard(s) or other normative document(s) (see page 2) pursuant to the provisions of the Statutory Instrument 2016 No. 1107 of the UK Parliament coming into force on the 8 <sup>th</sup> of December 2016, "The Equipment and Protective Systems Intended for Use in Potentially Explosive Atmospheres Regulations 2016". This product is labelled as follows:	
<b>Marking</b>	II 3G Ex ec IIC T6 Gc II 3D Ex tc IIIC T80°C Dc MIN22UKEX003X	
	Minebea Intec GmbH Hamburg, 03.02.2023	
	 ----- Dr. K. Sommer Managing Director	 ----- Dr. A. Böttger CTO
		 ----- Torben Hiller EX Approval Manager
	This declaration certifies conformity with the above mentioned UK Directives, but does not guarantee product attributes. Unauthorized product modifications make this declaration invalid. The safety information in the associated product documentation must be observed.	
	1/2 MIN22UKEX003X Rev. 00	



## Manufacturer's certificate



Compliance with the Essential Health and Safety Requirements has been assured by compliance with:

### Standards

EN IEC 60079-0:2018

Explosive atmospheres – Part 0: Equipment - General requirements

EN IEC 60079-7:2015 / A1:2018

Explosive atmospheres – Part 7: Equipment protection by increased safety "e"

EN 60079-31:2014

Explosive atmospheres – Part 31: Equipment dust ignition protection by enclosure "t"

This certificate was drawn on the basis of the following test report:

### Test Report

MTR22002

Minebea Intec GmbH, Hamburg, Germany

### Safety instructions

65835-790-16

### Ambient temperature

$-20^{\circ}\text{C} \leq T_{\text{AMB}} \leq +70^{\circ}\text{C}$

### Electrical Data

$U_n = 28 \text{ Vdc}$

$I_n = 500 \text{ mA}$

### IP Protection Class

IP66, IP69

For this product the following special conditions for safe use apply:

### Special Conditions

Follow the instructions given in the safety instructions.

Avoid electrostatic charging.

*The load cells and cables must be laid securely (fixed installation).*

2/2

MIN22UKEX003X Rev. 00

12.3 MEU23002



**EU-Declaration of Conformity**  
(in accordance with ISO/IEC 17050-1)

MEU23002 Rev. 0



**Minebea  
intec**  
*The true measure*

1. Product model / product number / solely valid for project number:  
 1.1 Pendeo® Process– Digital Precision Compression Load Cell / PR 6204B / ----
  
2. Name and address of the manufacturer (2.1) and his authorized representative (2.2):  
 2.1 Minebea Intec GmbH, Meiendorfer Straße 205 A, 22145 Hamburg, Germany  
 2.2 /
  
3. This declaration of conformity is issued under the sole responsibility of the manufacturer.
  
4. Object(s) of the declaration:  
 4.1 PR 6204B  
 4.2 PR 6204B (A.1)
  
5. The object(s) of the declaration described above is in conformity with the relevant Union harmonization legislation:  

	(4.1)	(4.2)
5.1 2014/30/EU	(6.1)	(6.1)
5.2 2011/65/EU	(6.2)	(6.2)
5.3 2014/34/EU	(6.3)	(6.3)
  
6. References to the relevant harmonized standards used or references to the other technical specifications in relation to which conformity is declared:  
 6.1 2014/30/EU EN 61326-1:2013  
 6.2 2011/65/EU EN IEC 63000:2018  
 6.3 2014/34/EU EN IEC 60079-0:2018, EN IEC 60079-7:2015/A1:2018, EN 60079-31:2014
  
7. The notified body w performed x and issued the certificate y relevant for z:  

	w	x	y	z
7.1	/	Manufacturer's certificate	MIN22ATEX005X	(4.2)

  
  

Minebea Intec GmbH  
Hamburg, 09. Feb. 2023

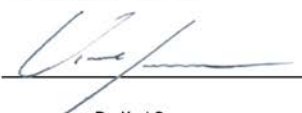

Dr. Karl Sommer  
COO

p.p.a



Dr. Axel Böttger  
CTO

i.A.



Oliver Freitag  
CE Certification

1/6



MEU23002 Rev. 0

### EU-Declaration of Conformity

(in accordance with ISO/IEC 17050-1)



A. Additional information on ( ):

A.1 (7.1) Marking



II 3G Ex ec IIC T6 Gc  
II 3D Ex tc IIIC T80°C Dc  
MIN22ATEX005X



# EU-Declaration of Conformity

(in accordance with ISO/IEC 17050-1)

MEU23002 Rev. 0

**Minebea**  
**intec**  
The true measure

български (bg)	čeština (cs)	dansk (da)
<p>Декларация за съответствие</p> <p>1. Модел на продукта / Номер на продукта / валидно само за номера на проекта:</p> <p>2. Наименование и адрес на производителя (2.1) и на неговия упълномощен представител (2.2):</p> <p>3. Настоящата декларация за съответствие е издадена на отговорността на производителя.</p> <p>4. Предмет(и) на декларацията:</p> <p>5. Предмет(и) (ите) на декларацията, описан(и) по-горе отговаря(т) на съответното законодателство на Съюза за хармонизиране.</p> <p>6. Позоваване на приложимите хармонизирани стандарти или позоваване на други технически спецификации, по отношение на които се декларира съответствие:</p> <p>7. Нотифицираният орган в извършил x и издаде сертификата y, отнасящ се за z:</p> <p>A. Допълнителна информация за ( ):</p> <p>A.1 Маркировка</p>	<p>Prohlášení o shodě</p> <p>1. Model výrobku / číslo výrobku / platné pouze pro číslo projektu:</p> <p>2. Jméno a adresa výrobce (2.1) a jeho zplnomocněného zástupce (2.2):</p> <p>3. Toto prohlášení o shodě se vydává na výhradní odpovědnost výrobce.</p> <p>4. Předmět(y) prohlášení:</p> <p>5. Výše popsaný předmět / Výše popsané předměty prohlášení je/ jsou ve shodě s příslušnými harmonizačními právními předpisy Únie.</p> <p>6. Odkazy na příslušné harmonizované normy, které byly použity, nebo na jiné technické specifikace, na jejichž základě se shoda prohlašuje:</p> <p>7. Oznamovaný subjekt v provedl x a vydal certifikát y relevantní z hlediska z:</p> <p>A. Další informace o ( ):</p> <p>A.1 Označení</p>	<p>Overensstemmelseerklæring</p> <p>1. Produktmodel / produktnummer / gælder kun for projektnummer:</p> <p>2. Fabrikantens (2.1) og dennes bemyndigede repræsentants (2.2) navn og adresse:</p> <p>3. Denne overensstemmelseerklæring udstedes på fabrikantens ansvar.</p> <p>4. Genstand(ene) for erklæringen:</p> <p>5. Genstand(ene) for erklæringen, som beskrevet ovenfor, er i overensstemmelse med den relevante EU-harmoniseringslovgivning:</p> <p>6. Referencer til de relevante anvendte harmoniserede standarder eller til de andre tekniske specifikationer, som der erklæres overensstemmelse med:</p> <p>7. Det bemyndigede organ w har foretaget x og udstedt attesten y, der gælder for z:</p> <p>A. Supplerende oplysninger om ( ):</p> <p>A.1 Mærkning</p>
Deutsch (de)	Ελληνικά (el)	español (es)
<p>Konformitätserklärung</p> <p>1. Produktmodell / Produktnummer / gilt ausschließlich für Projekt-Nr.:</p> <p>2. Name und Anschrift des Herstellers (2.1) und seines Bevollmächtigten (2.2):</p> <p>3. Die alleinige Verantwortung für die Ausstellung dieser Konformitätserklärung trägt der Hersteller.</p> <p>4. Gegenstände der Erklärung:</p> <p>5. Die oben beschriebenen Gegenstände der Erklärung erfüllen die einschlägigen Harmonisierungsrechtsvorschriften der Union:</p> <p>6. Angabe der einschlägigen harmonisierten Normen oder der anderen technischen Spezifikationen, die der Konformitätserklärung zugrunde gelegt wurden:</p> <p>7. Die notifizierte Stelle w hat x und die für z relevante Bescheinigung y ausgestellt:</p> <p>A. Zusatzangaben zu ( ):</p> <p>A.1 Kennzeichnung</p>	<p>Δήλωση συμμόρφωσης</p> <p>1. Μοντέλο προϊόντος / αριθμός προϊόντος / ισχύει μόνο για τον αριθμό του έργου:</p> <p>2. Ονομα και διεύθυνση του κατασκευαστή (2.1) και του εξουσιοδοτημένου αντιπροσώπου του (2.2):</p> <p>3. Η παρούσα δήλωση συμμόρφωσης εκδίδεται με αποκλειστική ευθύνη του κατασκευαστή.</p> <p>4. Στόχος της δήλωσης:</p> <p>5. Ο στόχος της δήλωσης που περιγράφεται παραπάνω είναι σύμφωνος με τη σχετική ενωσιακή νομοθεσία εναρμόνισης.</p> <p>6. Παραπομπές στα σχετικά εναρμονισμένα πρότυπα που χρησιμοποιήθηκαν ή παραπομπές στις λοιπές τεχνικές προδιαγραφές σε σχέση με τις οποίες δηλώνεται η συμμόρφωση:</p> <p>7. Ο κοινοποιημένος οργανισμός w διεξήγαγε x και εξέδωσε το πιστοποιητικό y όπως απαιτείται για z:</p> <p>A. Πρόσθετες πληροφορίες σχετικά με ( ):</p> <p>A.1 Σήμανση</p>	<p>Declaración de conformidad</p> <p>1. Modelo de producto/número de producto / únicamente válido para el número de proyecto:</p> <p>2. Nombre y dirección del fabricante (2.1) y de su representante autorizado (2.2):</p> <p>3. La presente declaración de conformidad se expide bajo la exclusiva responsabilidad del fabricante.</p> <p>4. Objeto(s) de la declaración:</p> <p>5. El/Los objeto(s) de la declaración descritos anteriormente son conformes con la legislación de armonización pertinente de la Unión Europea.</p> <p>6. Referencias a las normas armonizadas pertinentes utilizadas o referencias a las otras especificaciones técnicas respecto a las cuales se declara la conformidad:</p> <p>7. El organismo notificado W ha efectuado X y expedido el certificado Y relevante para Z:</p> <p>A. Información adicional en ( ):</p> <p>A.1 Marcado</p>



MEU23002 Rev. 0

## EU-Declaration of Conformity

(in accordance with ISO/IEC 17050-1)

**Minebea**  
**intec**  
The true measure

### eesti keel (et)

#### Vastavusdeklaratsioon

1. Tootemudel / tootenumber / kehtib vaid järgmise projekti puhul:
  2. Tootja nimi ja aadress (2.1) ning tema volitatud esindaja (2.2):
  3. Käesolev vastavusdeklaratsioon on välja antud tootja ainuvastutusel.
  4. Deklareeritav toode:
  5. Ülalkirjeldatud deklareeritav toode on kooskõlas asjaomaste liidu nihtlustamisaktidega või viited muudele tehnilistele spetsifikatsioonidele, millele vastavust deklareeritakse:
  7. Teavitatud asutus w teostas x ja andis välja töendi z, mis on asjakohane y-le:
- A. Lisateave järgmise kohta ( ):  
A.1 Märkus

### français (fr)

#### Déclaration de conformité

1. Modèle / numéro de produit / valable uniquement pour le numéro de projet:
  2. Nom et adresse du fabricant (2.1) et de son mandataire (2.2):
  3. La présente déclaration de conformité est établie sous la seule responsabilité du fabricant.
  4. Objet(s) de la déclaration :
  5. Le ou les objets de la déclaration décrite ci-dessus est/sont conforme(s) à la législation d'harmonisation de l'Union applicable :
  6. Références des normes harmonisées pertinentes appliquées ou des autres spécifications techniques par rapport auxquelles la conformité est déclarée :
  7. L'organisme notifié w a effectué x et a établi l'attestation y applicable à z :
- A. Informations complémentaires relatives à ( ):  
A.1 Marquage

### hrvatski (hr)

#### Izjava o sukladnosti

1. Model proizvoda / broj proizvoda / vrijedi samo za broj projekta:
  2. Naziv i adresa proizvođača (2.1) i njegovog ovlaštenog zastupnika (2.2):
  3. Za izdavanje ove izjave o sukladnosti odgovoran je isključivo proizvođač.
  4. Predmet(i) izjave:
  5. Predmet(i) navedene izjave je/su u skladu s mjerodavnim zakonodavstvom Unije o usklađivanju:
  6. Pozivanja na relevantne primjenjene uskladene norme ili pozivanja na ostale tehničke specifikacije u vezi s kojima se izjavljuje sukladnost:
  7. Prijavljeno tijelo w provelo je x i izdalo certifikat y koji je relevantan za z:
- A. Dodatne informacije o proizvodu ( ):  
A.1 Označavanje

### magyar (hu)

#### Megfelelőségi nyilatkozat

1. Termékneml / termékszám / kizárólag az alábbi projektszámhoz érvényes:
  2. A gyártó (2.1) vagy adott esetben meghatalmazott képviselőjének (2.2) neve és címe:
  3. Ezt a megfeleléségi nyilatkozatot a gyártó kizárólagos felelősége mellett adják ki.
  4. A nyilatkozat tárgya (z):
  5. A fent ismertetett nyilatkozat tárgya megfelel a vonatkozó uniós harmonizációs jogszabályoknak:
  6. Az alkalmazott harmonizált szabványokra való hivatkozás vagy az azokra az egyéb műszaki leírásokra való hivatkozás, amelyekkel kapcsolatban megfeleléségi nyilatkozatot tettek:
  7. A(z) w bejelentett szervezet elvégezte a(z) x eljárást, és kiállította a(z) z kapcsolódó y tanúsítványát:
- A. További információk ( ):  
A.1 Jelölés

### italiano (it)

#### Dichiarazione di conformità

1. Modello di prodotto / numero di prodotto / valido unicamente per numero di progetto:
  2. Nome e indirizzo del fabbricante (2.1) e del relativo rappresentante autorizzato (2.2):
  3. La presente dichiarazione di conformità è rilasciata sotto la responsabilità esclusiva del fabbricante.
  4. Oggetto/i della dichiarazione:
  5. L'oggetto o gli oggetti della dichiarazione di cui sopra sono conformi alla pertinente normativa di armonizzazione dell'Unione:
  6. Riferimento alle pertinenti norme armonizzate utilizzate o riferimenti alle altre specifiche tecniche in relazione alle quali è dichiarata la conformità:
  7. L'organismo notificato w ha effettuato x e rilasciato il certificato y pertinente a z:
- A. Informazioni aggiuntive su ( ):  
A.1 Marcatura

### Latvian kalba (lv)

#### Atbilstības deklarācija

1. Gaminio modelis / gaminio numeris / galioja tik projekta numerim:
  2. Gaminio (2.1) ir jo īpaši atstovo (2.2) pavadināms ir adrešs:
  3. Šī atbilstības deklarācija izdocta tik gaminioje atsakomybe.
  4. Deklarācijas objekts (objekti):
  5. Pirmiau aprašytas deklarācijas objekts (objekti) atitinka susijusius derinamuosius Sąjungos teises aktus:
  6. Susijusių taikytų darnųjų standartų nuorodos arba kitų techninių specifikacijų, pagal kurias buvo deklaruota atitiktis, nuorodos:
  7. Notifikuotijs įstaga w atliko x ir išdavė sertifikatą y dėl z:
- A. Papildoma informācija ( ):  
A.1 Zēnkināmas



# EU-Declaration of Conformity

(in accordance with ISO/IEC 17050-1)

MEU23002 Rev. 0

**Minebea**  
**intec**  
The true measure

## latviešu valoda (lv)

Atbilstības deklarācija  
1. Produkta modelis / produkta numurs / derīgais projekta Nr.:  
2. Ražotāja (2.1.) un tā pilnvarotā pārstāvja (2.2.) nosaukums un adrese:  
3. Šī atbilstības deklarācija ir izdota vienīgi uz ražotāja atbildību.  
4. Deklarācijas priekšmets vai priekšmeti:  
5. Iepriekš aprakstītais deklarācijas priekšmets vai priekšmeti atbilst attiecīgajam Savienības saskaņošanas tiesību aktam:  
6. Atsauces uz attiecīgajiem izstrādājumiem saskaņotajiem standartiem vai uz citām tehniskajām specifikācijām, attiecībā uz ko tiek deklarēta atbilstība:  
7. Paziņota struktūra w ir veikusi x un izmēģinājis sertifikātu y, kas attiecas uz z:  
A. Papildu informācija par ( ):  
A.1. Marķējums

## malta (mt)

Dikjarazzjoni ta' konformità  
1. Mudell tal-prodott / numru tal-prodott / validu biss għan-numru tal-progett:  
2. L-isem u l-indirizz tal-manifattur (2.1) u tar-rappreżentant awtorizzat tiegħu (2.2):  
3. Din id-dikjarazzjoni ta' konformità tinhareg taht ir-responsabbiltà unika tal-manifattur.  
4. L-għan(ijiet) tad-dikjarazzjoni:  
5. L-għan(ijiet) tad-dikjarazzjoni deskritt(i) hawn fuq huwa(huma) konformi mal-legislazzjoni ta' armonizzazzjoni rilevanti tal-Unjoni:  
6. Ir-referenzi għall-istandards armonizzati rilevanti li nużaw, jew ir-referenzi għall-ispeċifikazzjonijiet tekniċi l-oħra li skonthom qed tiġi ddikjarata l-konformità:  
7. Il-korp notifikat w wettaq x u hareġ iċ-certifikat y rilevanti għal z:  
A. Informazzjoni addizzjonali fuq ( ):  
A.1. Immarkar

## nederlands (nl)

Conformiteitsverklaring  
1. Productmodel / productnummer / uitsluitend geldig voor projectnummer:  
2. Naam en adres van de fabrikant (2.1) en zijn gemachtigde (2.2):  
3. Deze conformiteitsverklaring wordt verstrekt onder volledige verantwoordelijkheid van de fabrikant.  
4. Voorwerp(en) van de verklaring:  
5. Het (de) hierboven beschreven voorwerp(en) is (zijn) in overeenstemming met de desbetreffende harmonisatiewetgeving van de Unie:  
6. Vermelding van de toegepaste relevante geharmoniseerde normen of van de overige technische specificaties waarop de conformiteitsverklaring betrekking heeft:  
7. De aangemelde instantie w heeft een x uitgevoerd en het certificaat y verstrekt dat relevant is voor z:  
A. Aanvullende informatie over ( ):  
A.1. Markering

## polski (pl)

Deklaracja zgodności  
1. Model produktu / numer produktu / ważny wyłącznie dla projektu o numerze:  
2. Nazwa i adres producenta (2.1) oraz jego upoważnionego przedstawiciela (2.2):  
3. Niniejsza deklaracja zgodności wydana zostaje na wyłączną odpowiedzialność producenta.  
4. Przedmiot(-y) deklaracji:  
5. Wymieniony powyżej przedmiot (lub przedmioty) niniejszej deklaracji jest zgodny z odnoszonymi wymaganiami unijnego prawodawstwa harmonizacyjnego.  
6. Odwołania do odnoszących norm zharmonizowanych, które zastosowano, lub do innych specyfikacji technicznych, w stosunku do których deklarowana jest zgodność:  
7. Jednostka notyfikowana w przeprowadziła x i wydała certyfikat y i odpowiedni dla z:  
A. Informacje dodatkowe o ( ):  
A.1. Oznakowanie

## português (pt)

Declaração de conformidade  
1. Modelo do produto / número do produto / somente válido para o número de projeto:  
2. Nome e endereço do fabricante (2.1) e do seu mandatário (2.2):  
3. A presente declaração de conformidade é emitida sob a exclusiva responsabilidade do fabricante.  
4. Objeto(s) da declaração:  
5. O(s) objeto(s) da declaração acima descrito(s) está(ão) em conformidade com a legislação aplicável de harmonização da União:  
6. Referências às normas harmonizadas aplicáveis utilizadas ou às outras especificações técnicas em relação às quais é declarada a conformidade:  
7. O organismo notificado w realizou x e emitiu o certificado y relevante para z:  
A. Informações complementares relativa a ( ):  
A.1. Marcação

## română (ro)

Declarație de conformitate  
1. Modelul de produs / Număr produs / valabil numai pentru numărul proiectului:  
2. Denumirea și adresa producătorului (2.1) și a reprezentantului său autorizat (2.2):  
3. Prezenta declarație de conformitate este emisă pe răspunderea exclusivă a producătorului.  
4. Obiectul (obiectele) declarației:  
5. Obiectul (obiectele) declarației descrise mai sus sunt în conformitate cu legislația relevantă de armonizare a Uniunii:  
6. Trimiteri la standardele armonizate relevante folosite sau trimiteri la celelalte specificații tehnice în legătură cu care se declară conformitatea:  
7. Organismul notificat w a efectuat x și a emis certificatul y corespunzător pentru z:  
A. Informații suplimentare despre ( ):  
A.1. Marcă



MEU23002 Rev. 0

## EU-Declaration of Conformity

(in accordance with ISO/IEC 17050-1)

**Minebea**  
**intec**  
The true measure

## slovenščina (sk)

Vyhlašenje o zhode  
1. Model výrobnú / číslo výrobnú / platné len pre číslo projektu:  
2. Meno/názov a adresa výrobcu (2.1) a jeho splnomocneného zástupcu (2.2):  
3. Toto vyhlásenie o zhode sa vydáva na vlastnú zodpovednosť výrobcu.  
4. Predmet(-y) vyhlásenia:  
5. Uvedený predmet či uvedené predmety vyhlásenia sú v zhode s príslušnými harmonizačnými právnymi predpismi Únie:  
6. Odkazy na príslušné použité harmonizované normy alebo odkazy na iné technické špecifikácie, v súvislosti s ktorými sa zhoda vyhlasuje:  
7. Notifikovaný orgán v vykonal x a vydal certifikát y relevantný pre z:  
A. Doplňujúce informácie o ( ):  
A.1 Označenie

## slovenščina (sl)

Izjava o skladnosti  
1. Model proizvoda / serijska številka proizvoda / veljavno samo za številko projekta:  
2. Ime in naslov proizvajalca (2.1) ter njegovega pooblaščenega zastopnika (2.2):  
3. Za izdajo te izjave o skladnosti je odgovoren izključno proizvajalec.  
4. Predmet(i) izjave:  
5. Predmet(i) navedene izjave je (so) v skladu z ustreznimi zakonodajo Unije o harmonizaciji:  
6. Sklicevanja na uporabljene ustrezne harmonizirane standarde ali sklicevanja na druge tehnične specifikacije v zvezi s skladnostjo, ki je navedena v izjavi:  
7. Priglašeni organ w je izvedel x in izdal certifikat y, pomemben za z:  
A. Dodatne informacije o ( ):  
A.1 Oznaka



## suomi (fi)

Vaativuorukäytännön  
1. Tuotemalli / tuotenumero / koskevan vain projektinumero:  
2. Valmistajan (2.1) ja valtuutetun edustajan (2.2) nimi ja osoite:  
3. Tämä vaatimustenmukaisuusvakuutus on annettu valmistajan yksinomisella vastuulla.  
4. Vakuutuksen kohde (kohteet):  
5. Edellä kuvattu (kuvatut) vakuutuksen kohde (kohteet) on (ovat) asiaa koskevan unionin yhdenmukaistamislainsäädännön vaatimusten mukainen (mukaisia):  
6. Viittaus mihin asiaa koskeviin yhdenmukaistettuihin standardeihin, joita on käytetty, tai viittaus muihin teknisiin eritelmiin, joiden perusteella vaatimustenmukaisuusvakuutus on annettu:  
7. Ilmoitettu laitos w suoritti x ja antoi todistuksen y liittyen z:  
A. Lisätietoja ( ):  
A.1 Merkintä

## svenska (sv)

Försäkran om överensstämmelse  
1. Produktmodell / produktnummer / gäller endast för projektnummer:  
2. Tillverkarens namn och adress (2.1) och dess auktoriserade representant (2.2):  
3. Denna försäkran om överensstämmelse utfärdas på tillverkarens eget ansvar.  
4. Föremål för försäkran:  
5. Föremålet/föremålen för försäkran ovan överensstämmer med den relevanta harmoniserade unionslagstiftningen:  
6. Hänvisningar till de relevanta harmoniserade standarder som använts eller hänvisningar till de andra tekniska specifikationer enligt vilka överensstämmelsen försäkras:  
7. Det anmälda organet w har utfört x och utfärdat intyget y relevant för z:  
A. Ytterligare information om ( ):  
A.1 Märkning

## 12.4 R60/2017-A-NL1-23.01

		<b>OIML Certificate</b>	
<b>OIML Member State</b> The Netherlands		Number R60/2017-A-NL1-23.01 revision 0 Project number 3458015 Page 1 of 3	
<b>Issuing authority</b>	NMI Certin B.V. Person responsible: M.Ph.D. Schmidt		
<b>Applicant and Manufacturer</b>	Minebea Intec GmbH Meiendorfer Strasse 205 A D-22145 Hamburg Germany		
<b>Identification of the certified type</b>	A <b>compression load cell</b> , with strain gauges, equipped with electronics.		
	Registered trade name	: Minebea Intec GmbH	
	Type	: PR 6204B	
<b>Characteristics</b>	See next page		
This OIML Certificate is issued under scheme A.			
This Certificate attests the conformity of the above identified Type (represented by the sample(s) identified in the OIML Test Report) with the requirements of the following Recommendation of the International Organization of Legal Metrology (OIML):			
<b>OIML R 60-1:2017</b> for accuracy class C or D			
This Certificate relates only to the metrological and technical characteristics of the type of measuring instrument covered by the relevant OIML International Recommendation above-identified. This Certificate does not bestow any form of legal international approval.			
<i>Important note:</i> Apart from the mention of the Certificate's reference number and the name of the OIML Member State in which the Certificate was issued, partial quotation of the Certificate and of the associated OIML Test Report(s) is not permitted, although either may be reproduced in full.			
<b>Issuing Authority</b>	<b>NMI Certin B.V., OIML Issuing Authority NL1</b> 22 May 2023		
	<b>Certification Board</b>		
NMI Certin B.V. Thijsseweg 11 2629 JA Delft The Netherlands T +31 88 6362332 certin@nmi.nl www.nmi.nl	This document is issued under the provision that no liability is accepted and that the applicant shall indemnify third-party liability.	This document is digitally signed and sealed. The digital signature can be verified in the blue ribbon on top of the electronic version of this certificate.	
	The notification of NMI Certin B.V. as Issuing Authority can be verified at <a href="http://www.oiml.org">www.oiml.org</a>		



# OIML Certificate

**OIML Member State**  
The Netherlands

Number R60/2017-A-NL1-23.01 revision 0  
Project number 3458015  
Page 2 of 3

The conformity was established by the results of tests and examinations provided in the associated OIML Type Evaluation Reports:

- No. NMI-3458015-01 dated 19 May 2023 that includes 17 pages;
- No. NMI-3458015-02 dated 19 May 2023 that includes 48 pages;
- No. NMI-3458015-03 dated 19 May 2023 that includes 61 pages;
- No. NMI-3458015-04 dated 19 May 2023 that includes 48 pages;
- No. NMI-3458015-05 dated 19 May 2023 that includes 48 pages.

**Characteristics of the load cell:**

Characterization of load cell capabilities	Digital load cell with data processing							
Maximum capacity (E <sub>max</sub> )	500 kg up to 1000 kg	1000 kg up to 2000 kg	2000 kg up to 3000 kg		3000 kg up to 20000 kg		20000 kg up to and including 75000 kg	
Minimum dead load	0 kg							
Accuracy Class	D		C	D	C	D	C	D
Maximum number of load cell intervals (n) <sup>(1)</sup>	1000		3000	1000	3000	1000	6000	1000
Ratio of minimum LC Verification interval <sup>(1)</sup> Y = E <sub>max</sub> / V <sub>min</sub>	2500	5000	10000		14000		20000	
Ratio of minimum dead load output return <sup>(1)</sup> Z = E <sub>max</sub> / (2 * DR)	1000		3000		3000		8000	
Temperature range	Class C: -10 °C / + 40 °C Class D: -25 °C / + 55 °C							
Fraction p <sub>LC</sub>	0,7							
Humidity Class	CH							
Safe overload	0,5 t: 600% of E <sub>max</sub> 1 t: 300% of E <sub>max</sub>		2 t: 150% of E <sub>max</sub>		3 t: 150% E <sub>max</sub> 5 t: 150% E <sub>max</sub> 10 t: 150% E <sub>max</sub>		20 t: 187% of E <sub>max</sub> 25 t: 150% of E <sub>max</sub> 30 t: 250% of E <sub>max</sub> 50 t: 150% of E <sub>max</sub> 60 t: 125% of E <sub>max</sub> 75 t: 100% of E <sub>max</sub>	
Recommended excitation	12-28V DC supplied by 100-240V AC power supply							
Transducer material	Stainless steel							
Number of counts for E <sub>max</sub>	≥ Y * 5 / p <sub>LC</sub>							
Atmospheric protection	Hermetically welded							



# OIML Certificate

**OIML Member State**  
The Netherlands

Number R60/2017-A-NL1-23.01 revision 0  
Project number 3458015  
Page 3 of 3

Electromagnetic environment class	E2
Software identification	Version number: 01.01.01

**Remark:**

1. The characteristics for  $n_{max}$ , Y and Z can be reduced separately.

Each load cell produced is provided with an accompanying document with information about its characteristics.

The above identified Type (represented by the sample(s) identified in the OIML Test Report) have been found to comply with the additional national requirements established by the United States of America (NIST Handbook 44 and NCWM Publication 14), included in the Utilizer Declaration:

- R 60 OIML-CS rev.2 Additional requirements from the United States Accuracy class III L;
- R 60 OIML-CS rev.2 Additional requirements from the United States Marking requirements.

**Revision History**

Revision	Date	Change(s)
0	22 May 2023	Initial issue.

12.5 TC12542



## Test Certificate Parts Certificate

Number **TC12542** revision 0  
Project number 3458015  
Page 1 of 1

Issued by	NMI Certin B.V.
In accordance with	WELMEC 8.8 2017, WELMEC 2.4 2021, OIML R 60 (2021) EN 45501:2015, WELMEC 7.2, 2021.
Producer	Minebea Intec GmbH Meiendorfer Strasse 205 A D-22145 Hamburg Germany
Measuring instrument	<p>A <b>compression load cell</b>, with strain gauges, equipped with electronics, tested as a part of a weighing instrument.</p> <p>Registered trade name : Minebea Intec GmbH Designation : PR 6204B</p> <p>Further properties are described in the annexes:</p> <ul style="list-style-type: none"> <li>- Description TC12542 revision 0;</li> <li>- Documentation folder TC12542-1.</li> </ul> <p>An overview of performed tests is given in the annex:</p> <ul style="list-style-type: none"> <li>- Description TC12542 revision 0.</li> </ul>
Initially issued	22 May 2023

**Issuing Authority**

**NMI Certin B.V.**  
22 May 2023

**Certification Board**

NMI Certin B.V.  
Thijssseweg 11  
2629 JA Delft  
The Netherlands  
T +31 88 6362332  
certin@nmi.nl  
www.nmi.nl

This document is issued under the provision that no liability is accepted and that the producer shall indemnify third-party liability.

Reproduction of the complete document only is permitted.

This document is digitally signed and sealed. The digital signature can be verified in the blue ribbon on top of the electronic version of this certificate.





## Description

Number **TC12542** revision 0  
 Project number 3458015  
 Page 1 of 4

### 1 General information about the load cell

All properties of the load cell, whether mentioned or not, shall not be in conflict with the standards mentioned in this certificate.

This certificate is the positive result of the applied voluntary, modular approach, for a component of a measuring instrument, as described in WELMEC 8.8. The complete measuring instrument must be covered by relevant metrological certification that is valid in the country where the instrument is put into use.

#### 1.1 Essential parts

Number	Pages	Description	Remark
12542/0-01	1	Outline drawing	Mechanical
12542/0-02	2	Measuring element	-
12542/0-03	3	SDLC_TOP electronics board	Electrical, PCB with parts list
12542/0-04	3	SDLC_BOTTOM electronics board	Electrical, PCB with parts list

#### Cable:

- The cable is shielded; the shield is connected to the load cell.

#### EMI protection measures:

- A/D board is located inside the metal load cell enclosure.



## Description

Number **TC12542** revision 0  
 Project number 3458015  
 Page 2 of 4

### 1.2 Essential characteristics

Characterization of load cell capabilities	Digital load cell with data processing							
Maximum capacity ( $E_{max}$ )	500 kg up to 1000 kg	1000 kg up to 2000 kg	2000 kg up to 3000 kg		3000 kg up to 20000 kg		20000 kg up to and including 75000 kg	
Minimum dead load	0 kg							
Accuracy Class	D		C	D	C	D	C	D
Maximum number of load cell intervals (n) <sup>(1)</sup>	1000		3000	1000	3000	1000	6000	1000
Ratio of minimum LC Verification interval <sup>(1)</sup> $Y = E_{max} / V_{min}$	2500	5000	10000		14000		20000	
Ratio of minimum dead load output return <sup>(1)</sup> $Z = E_{max} / (2 * DR)$	1000		3000		3000		8000	
Temperature range	Class C: -10 °C / + 40 °C Class D: -25 °C / + 55 °C							
Fraction $p_{LC}$	0,7							
Humidity Class	CH							
Safe overload	0,5 t: 600% of $E_{max}$ 1 t: 300% of $E_{max}$		2 t: 150% of $E_{max}$		3 t: 150% $E_{max}$ 5 t: 150% $E_{max}$ 10 t: 150% $E_{max}$		20 t: 187% of $E_{max}$ 25 t: 150% of $E_{max}$ 30 t: 250% of $E_{max}$ 50 t: 150% of $E_{max}$ 60 t: 125% of $E_{max}$ 75 t: 100% of $E_{max}$	
Recommended excitation	12-28V DC supplied by 100-240V AC power supply							
Transducer material	Stainless steel							
Number of counts for $E_{max}$	$\geq Y * 5 / p_{LC}$							
Atmospheric protection	Hermetically welded							
Electromagnetic environment class	E2							
Software identification	Version number: 01.01.01							

Remark:

1. The characteristics for  $n_{max}$ , Y and Z can be reduced separately.



## Description

Number **TC12542** revision 0  
 Project number 3458015  
 Page 3 of 4

### List of legally relevant functions:

- Linearity compensation: linearization based on a polynomial approximation;
- Zero offset correction and scaling;
- Creep and span compensation;
- Temperature compensation of zero, span and creep;
- The software seal uses a CRC 32 on the firmware and parameters checksum.

### Software:

- The identification number can be displayed using the device that displays the primary indications, with the xBPI command 0x1805;
- Firmware and parameter CRC32 checksum can be requested with the xBPI command 0x1804;
- The load cell has embedded software (OIML R 76-1 (2006));
- Software specification (WELMEC 7.2):
  - Software type P;
  - Risk Class B;
  - Extension T.

### Data transmission:

The load cell is equipped with one of the following protective interfaces that have not to be secured:

- RS485.

### Adjustment procedure:

- The load cell can only be adjusted in the factory and after that it is sealed by a CRC 32 checksum.

### 1.3 Essential shapes

Number	Pages	Description	Remark
12542/0-01	1	Outline drawing	Mechanical
12542/0-02	2	Measuring element	-

The descriptive markings plate is secured against removal by sealing or will be destroyed when removed and contains at least the information and markings as described in OIML R 60 (2021) and:

- This certificate number TC12542 (in the countries where it is mandatory);
- Producers name or mark.

### 1.4 Conditional parts

- Power supply for digital load cells type PR 6024/62S 100-240V AC to 24 V DC;
- Junction box for digital load cells type PR 6024/68S.

## 2 Seals

This load cell can only be used in combination with an indicator that does not allow changing of the adjustment data of the load cell using any interface.

It is not necessary to seal the connecting cable of the load cell or the junction box. The load cells are paired to the indicator by software and serial number at the time of putting into use. Firmware and parameter settings are sealed by a CRC32 checksum.



## Description

Number **TC12542** revision 0  
Project number 3458015  
Page 4 of 4

### 3 Conditions for conformity assessment

Each load cell produced is provided with an accompanying document with information about its characteristics, including the CRC32 checksum value.

The compatibility of load cells and indicator is established by the manufacturer by means of the compatibility of modules form, contained in EN45501:2015 clause F.5, at the time of putting into use.



Other parties may use this certificate without the written permission of the producer.

When the PR 6024/625 power supply is not used, the load cell equipped with electronics may be powered from the 12-28 V DC power supply of an indicator or terminal. For the weighing instrument the voltage interruptions, short voltage reductions, voltage transients and surges on the power supply lines shall be considered.

### 4 Reports

An overview of performed tests is given in the evaluation report ER12542 revision 0.

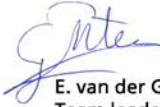
## 12.6 ER12542

		<b>Evaluation report</b>
		Number <b>ER12542</b> revision 0 Project number 3458015 Page 1 of 3
Issued by	NMI Certin B.V.	
Relevant document	WELMEC 8.8 General and Administrative Aspects of the Voluntary System of Modular Evaluation of Measuring instruments under the MID.	
Producer	Minebea Intec GmbH Meiendorfer Strasse 205 A D-22145 Hamburg Germany	
Measuring instrument	A <b>load cell</b> Type : PR 6204B	
Result	<p>This Evaluation Report has been issued in support of certificate TC12542 revision 0, demonstrating that the measuring instrument has been tested and approved in accordance with the harmonized standards or normative documents as mentioned above and on the following pages.</p> <p>The executed evaluations, reference documents and reports used during the examination are described on the following pages.</p>	
Issue Date	22 May 2023	
	 <b>E. van der Grinten</b> Team leader Weighing	
	<b>NMI Certin B.V.</b> Thijsseweg 11 2629 JA Delft The Netherlands T +31 88 6362332 certin@nmi.nl www.nmi.nl	This document is issued under the provision that no liability is accepted and that the producer shall indemnify third-party liability.
		Reproduction of the complete document only is permitted.
		



# Evaluation report

Number **ER12542** revision 0  
 Project number 3458015  
 Page 2 of 3

## 1 Harmonized standards, normative documents and / or recommendations

The load cell is examined in accordance with the relevant document listed in this Evaluation Report, page 1.

The following harmonized standards, normative documents and / or recommendations are applied:

- OIML R 60 (2021) Metrological regulation for load cells;
- EN 45501:2015 Metrological aspects of non-automatic weighing instruments;
- WELMEC 2.10 2021 Technical Implementation of The Modular Evaluation for Non-Automatic Weighing and Automatic Weighing Instruments.
- WELMEC 7.2 2022 Software Guide;
- R 60 OIML-CS rev.2 Additional requirements from the United States Accuracy class IIII;
- R 60 OIML-CS rev.2 Additional requirements from the United States Marking requirements.

## 2 Reports

The conformity was established by the results of tests and examinations provided in the associated reports:

Test	Part / Type	Report	Remarks
Disturbance tests	Model: PR 6224B/30t C6	NMi-3458015-01	-
Complete evaluation (including NTEP)	Model: PR 6204B/2t C3	NMi-3458015-02	-
	Model: PR 6224B/20t C6	NMi-3458015-03	
	Model: PR 6204B/2t D1	NMi-3458015-04	
	Model: PR 6224B/20t D1	NMi-3458015-05	
Software	Model: PR 6224B	NMi-3458015-06	WELMEC 7.2 2022

A report can be a test report, an evaluation report, a type evaluation report and/or a pattern evaluation report.

## 3 Additional Evaluations

This Evaluation Report is supplemented by the following additional evaluations:

Test	Part / Type	Document	Remarks
Load cell family	Specifications included without testing: 500 kg ≤ E <sub>max</sub> ≤ 75000 kg	R 60-2 (2021) clause 2.4	-



# Evaluation report

Number **ER12542** revision 0  
 Project number 3458015  
 Page 3 of 3

## 4 Revision History

Project no.	Rev.	Date	Report / Document	Description / Remarks
3458015	0	2023-05-22	TC12542-1 NMI-3458015-01 NMI-3458015-02 NMI-3458015-03 NMI-3458015-04 NMI-3458015-05 NMI-3458015-06	Initial Issue

Published by  
Minebea Intec GmbH | Meiendorfer Strasse 205 A | 22145 Hamburg, Germany  
Phone: +49.40.67960.303 | Email: [info@minebea-intec.com](mailto:info@minebea-intec.com)  
[www.minebea-intec.com](http://www.minebea-intec.com)

