

## Installation and Calibration Manual

# Transmitter

## MP 26

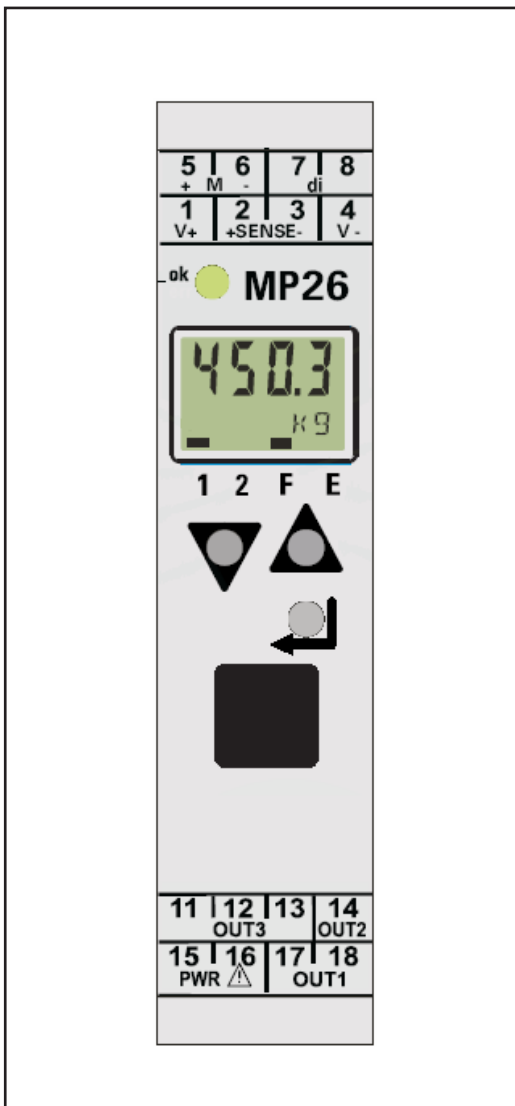

**Please note**

Any information in this document is subject to change without notice and does not represent a commitment on the part of Minebea Intec unless legally prescribed. This product should be operated only by trained and qualified personnel. In correspondence concerning this product the type, name and release number as well as all license numbers in relation to the product have to be quoted.

**Bitte beachten**

Alle Angaben in diesem Dokument sind - soweit nicht gesetzlich vorgegeben - unverbindlich für Minebea Intec und stehen unter Änderungsvorbehalt. Die Bedienung des Produktes darf nur von geschultem, fach- und sachkundigem Personal durchgeführt werden. Bei Schriftwechsel über dieses Produkt bitte Typ, Bezeichnung und Versionsnummer sowie alle mit dem Produkt in Zusammenhang stehenden Lizenznummern angeben.

## Table of Contents

TABLE OF CONTENTS.....	1
<b>1. MP 26 TRANSMITTER.....</b>	<b>3</b>
1.1. DESCRIPTION.....	3
1.1.1. Versions.....	3
1.1.2. Transmitter Overview / Features.....	3
1.2. HOUSING.....	4
1.3. DISPLAYS AND CONTROLS.....	6
<b>2. INSTALLATION.....</b>	<b>8</b>
2.1. CONNECTING THE SUPPLY VOLTAGE.....	8
2.2. CONNECTING THE LOAD CELL.....	8
2.3. CONNECTING DIGITAL INPUT ‘DI’.....	8
2.4. CONNECTING OUTPUTS OUT1 / OUT2.....	9
2.5. CONNECTING OUTPUT OUT3.....	10
<b>3. OPERATION VIA FRONT KEYS.....</b>	<b>11</b>
3.1. POWER ON.....	11
3.2. STATUS LED.....	11
3.3. DISPLAY.....	11
3.4. KEY PAD.....	12
3.4.1. Enter Key Functionality.....	12
3.4.2. Increment & Decrement Key Functionality.....	13
3.5. CONFIGURATION LEVELS.....	14
3.6. CALIBRATION.....	14
3.7. PARAMETER AND CONFIGURATION.....	15
3.7.1. Device.....	15
3.7.2. Zero Setting.....	16
3.7.3. Tare Setting.....	17
3.7.4. Limit Value Processing.....	18
3.8. RESET TO FACTORY SETTINGS.....	18
<b>4. CALIBRATION.....</b>	<b>19</b>
4.1. GENERAL.....	19
4.2. CALIBRATION.....	20
4.3. CALIBRATION VIA THE DEVICE.....	21
4.3.1. Initial Setting via the Device.....	22
4.3.2. Calibration by Load.....	26
4.3.3. Dead Load Correction.....	28
4.3.4. Calibration by Value.....	30
4.4. ZERO SETTING.....	33
4.5. TARE SETTING.....	34
4.6. EXAMPLE: CALIBRATION BY VALUE.....	35
4.7. SETTING THE LOW PASS FILTER AND BANDWIDTH.....	36
<b>5. CONFIGURING OUTPUTS.....</b>	<b>37</b>
5.1. OVERVIEW.....	37
5.2. CONFIGURING OUT.1 AND OUT.2.....	37
5.2.1. Define the Limits.....	38
5.2.2. Configure the Output.....	39
5.2.3. Setting Values for Limit Processing.....	39
5.2.4. Operating Principle: Limit Value Processing.....	40
5.3. OUTPUT OUT.3 (ANALOG).....	41
5.3.1. Analog Output Configuration Example.....	41

<b>6.</b>	<b>POSSIBLE ERRORS &amp; REMEDIES</b> .....	<b>42</b>
6.1.	GENERAL.....	42
6.2.	ERROR LIST .....	43
6.3.	DETECTION AND DISPLAY OF SENSOR AND WIRING ERRORS.....	44
<b>7.</b>	<b>TECHNICAL DATA</b> .....	<b>45</b>
7.1.	INPUTS.....	45
7.1.1.	<i>Input M</i> .....	45
7.1.2.	<i>Digital Input DII</i> .....	45
7.2.	OUTPUTS .....	46
7.2.1.	<i>Relay Outputs OUT1, OUT2</i> .....	46
7.2.2.	<i>OUT3 as Universal Output</i> .....	46
7.3.	GALVANIC ISOLATION.....	47
7.4.	POWER SUPPLY .....	47
7.4.1.	<i>AC Supply</i> .....	47
7.4.2.	<i>Universal supply 24 V UC</i> .....	47
7.4.3.	<i>Behaviour with power failure</i> .....	47
7.5.	ENGINEERING FRONT INTERFACE.....	48
7.6.	ENVIRONMENTAL CONDITIONS .....	48
7.6.1.	<i>Protection mode</i> .....	48
7.6.2.	<i>Permissible temperatures</i> .....	48
7.6.3.	<i>Humidity</i> .....	48
7.6.4.	<i>Shock and vibration</i> .....	48
7.6.5.	<i>Electromagnetic compatibility</i> .....	48
7.7.	GENERAL.....	49
7.7.1.	<i>Housing front</i> .....	49
7.7.2.	<i>Connecting terminals</i> .....	49
7.7.3.	<i>Electrical safety</i> .....	49
7.7.4.	<i>Certifications</i> .....	49
7.7.5.	<i>Electrical connections</i> .....	49
7.7.6.	<i>Mounting method</i> .....	49

## 1. MP 26 Transmitter

### 1.1. Description

The instrument is equipped with a monochrome, two-line 4-character display and a keypad which contains 3 keys. The instrument is a weighing system, especially designed for tank & hopper weighing, platform scales & weight transmitters in industrial application.

#### 1.1.1. Versions

MP 26 Transmitter 

9	4	0	8	-	8	0	0	-	2	6	Y	1
---	---	---	---	---	---	---	---	---	---	---	---	---

Y → 0 MP 26/00 90 to 260 V AC

Y → 1 MP 26/01 18 to 30 V AC / 18 to 31 VDC

A label is affixed to the rear panel of the instrument which contains information about the product. A sample is given below:

**TYP:** MP26/01

**NC:** 9408-800-26011

**Ident:** 622653810 0003

**Vers:** 1.1

**Ser .No.** 80 268 09530

#### 1.1.2. Transmitter Overview / Features

- Compact construction, only 22.5 mm wide
- Clips onto top-hat DIN rail
- Plug-in screw ports or spring clamp connectors
- Dual-line LC display with additional display elements
- Process values always in view
- Convenient 3-key operation
- Strain gauge input with high signal resolution (>15 bits)
- Universal output with high resolution (14 bits) as combined current / voltage output
- Quick response, only 50 ms cycle time, i.e. also suitable for fast signals
- Two relay outputs
- Customer-specific linearization
- Tare function
- Min/max indicator ("slave pointer")
- Logical linking of digital outputs, e.g. for common alarms
- Preset for output value
- Galvanic insulation is provided between inputs and outputs as well as from the supply voltage and communication interfaces.

## 1.2. Housing

The entire housing is IP20 Protected. The overall dimensions of the device are 117.5 x 22.5 x 99 mm (L x W x H).

Dimensions

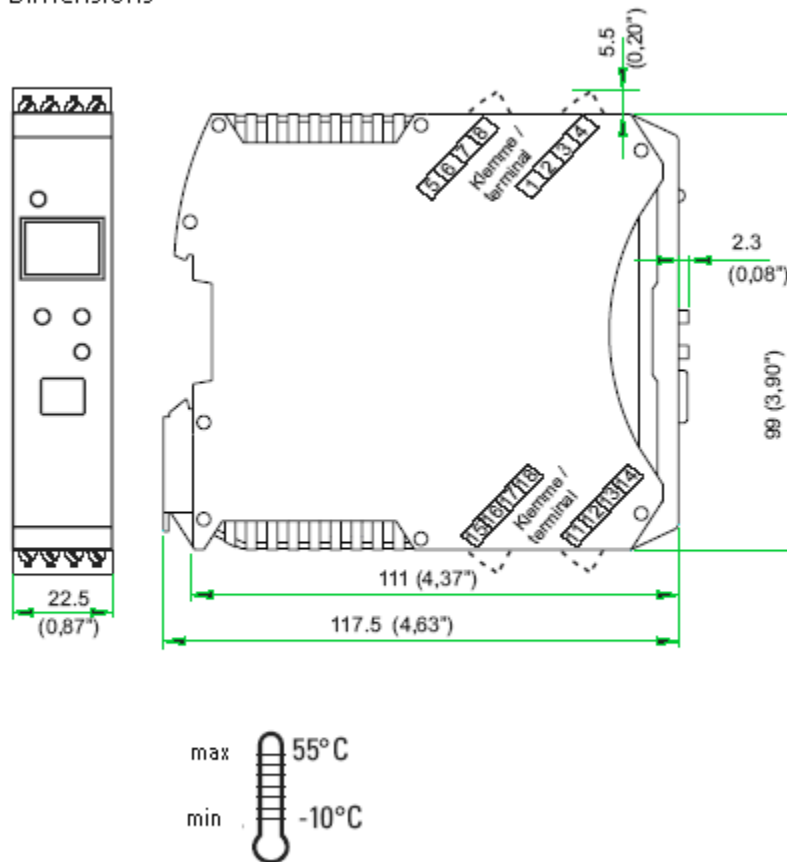

The unit is designed for vertical mounting on 35 mm top-hat rails to EN 50022. If possible, the place of installation should be free of vibration, aggressive media (e.g. acid, lye), liquid, dust or aerosol.

## Mounting & Dismounting the Device

The instruments can be mounted directly side by side. For mounting and dismounting, a minimum of 8 cm free space above and below the units should be provided.

Mounting

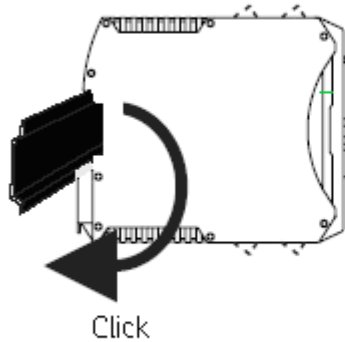

Dismounting

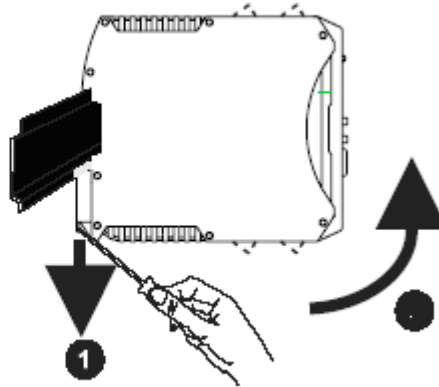

For mounting, simply clip the unit onto the top-hat rail from the top and click it into position. To dismount the unit, pull the bottom catch downwards using a screwdriver and remove the unit upwards

**Note:**

*The transmitter MP 26 does not contain any maintenance parts, i.e. the unit need not be opened by the customer.*

*The unit may be operated only in environments for which it is suitable due to its protection type. The housing ventilation slots must not be covered.*

*In plants susceptible to transient voltage peaks, the instruments must be equipped with additional protective filters or voltage limiters!*

**CAUTION!**

*The instrument contains electrostatically sensitive components.*

*To maintain contamination degree 2 according to EN 61010-1, the instrument must not be installed below contactors or similar units from which conducting dust or particles might settle.*

### 1.3. Displays and Controls

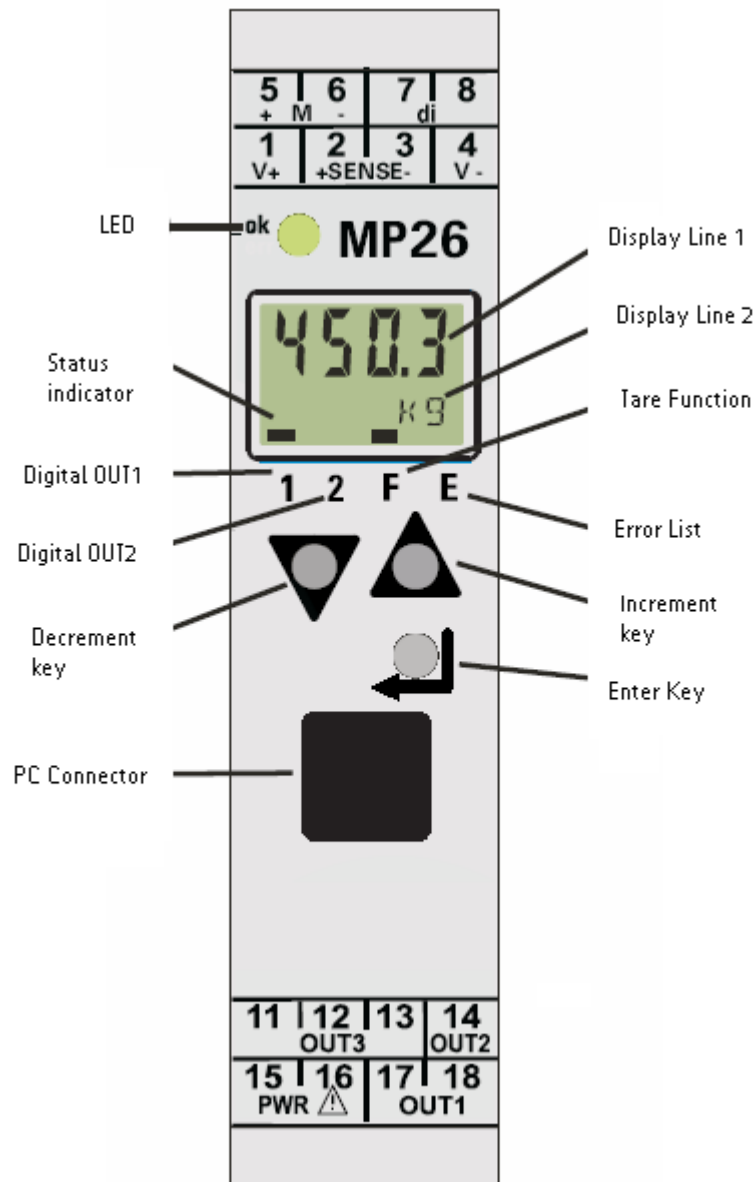

**Display Line 1:** Displays process value

**Display Line 2:** Displays unit / extended operating level / error list / Conf and PArA level values

**Status Indicator:** The statuses of the active functions are displayed as bars above the corresponding functionality.

**Tare Function:** The bar symbol above F in display line 2 indicates that tare is active.

**Error:** The bar symbol above E in display line 2 indicates an error has occurred. The error list can be viewed by pressing the enter key.

**Increment Key:** Is used to increment the values / slave pointer/ to display maximum value.

**Enter Key:** Is used to select extended operating level or error list, parameter, configurations and installations levels.

**LEDs:** This LED indicates the status of the device. There are 3 color codings:

- green: limit value 1 OK
- red: limit value 1 active
- red blinking: instrument fault, configuration error

**Digital OUT1:** The bar displayed above 1 indicates the switching status of output OUT1 active.

**Digital OUT2:** The bar displayed above 2 indicates the switching status of output OUT2 active.

**Decrement Key:** Is used to decrement the values / slave pointer/ to display minimum value.

**PC Connector:** Slot for connecting the device to PC to ease work with the MP26/10 tool. To facilitate withdrawal of the PC connector from the instrument, press the plug to the left.

**Note:**

*The second LCD line normally shows the set point. When moving over to the parameter setting, configuration or calibration level and at the extended operating level, the parameter name and value are displayed alternately.*

## 2. Installation

### 2.1. Connecting the Supply Voltage

Depending on the device version, connect the supply voltage as below:

MP 26/00	90...260 V AC	ports: 15, 16
MP 26/01	24 V AC / DC	ports: 15, 16

### 2.2. Connecting the Load Cell

The device can be connected to 4-wire or 6-wire technology load cells. 6-wire technology load cells can be connected directly as shown in figure.

If 4-wire technology is used:

short V + and S+  
short V - and S-

Excitation voltage for bridge V+, V-	ports: 1, 4
Excitation voltage measuring signal S+, S-	ports: 2, 3
Bridge signal M+, M-	ports: 5, 6

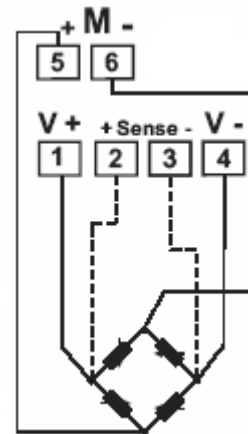

Measurement and data lines should be kept separate from control and power supply cables. Sensor measuring cables should be twisted and screened, with the screening connected to earth clamp.

### 2.3. Connecting Digital Input 'di'

Input 'di1' is a digital input to the device which has to be connected as a potential free contact. This di1 can be used for operation disabling, reset of stored alarms and the min/max indicator to enable the tare function and zero setting. It is configurable as a direct or inverse switch or push button.



Control input (as a potential free contact)	ports: 7, 8
Switched voltage:	5 V
Current:	0.5 mA

## 2.4. Connecting Outputs OUT1 / OUT2

Two digital outputs can be set from the device. The outputs are activated according to the configuration and parameter settings. The relay outputs should be max. 250V/2A.

**No** contact should exist between common terminals.

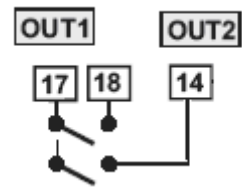

OUT1 ports: 17, 18

OUT2 ports: 17, 14

Contact type: 2 normally open relay outputs with common contact connections (galvanic insulation is provided between inputs and outputs )

Max. contact rating: 500 VA, max. 250 V, max. 2A at 48...62 Hz, ohmic load

Min. contact rating: 6 V, 1 mA DC

Switching cycles (electrical) for  $I = 1 \text{ A}/2 \text{ A}$ :  
 $\geq 800,000/500,000$  (at  $\sim 250\text{V}$  (ohmic load))

**Note:**

*If relays OUT1, 2 and 3 are used to operate external contactors, these must be fitted with RC snubber circuits according to manufacturer specifications to prevent excessive voltage peaks at switch-off.*

## 2.5. Connecting Output OUT3

The Out3 is an analog output through which voltage or current can be led based on the configuration.

Current (0...20mA)    ports: 11, 12  
Voltage (0...10V)    ports: 12, 13

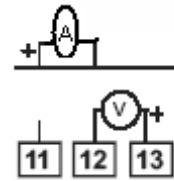

Its current output is configurable 0/4...20 mA, short-circuit proof.

Control range:        -0.5...23 mA  
Load:                     $\leq 600 \Omega$   
Load effect:            $\leq 0.02\%$   
Resolution:             $\leq 1.5 \mu\text{A}$   
Error:                     $\leq 0.1\%$

Its voltage output is configurable 0/2...10V, not permanently short-circuit proof

Control range            0.15...11.5 V  
Load:                      $\geq 2 \text{ k}\Omega$   
Load effect:              $\leq 0.06\%$   
Resolution:               $\leq 0.75 \text{ mV}$   
Error:                      $\leq 0.1\%$   
Additional error when    $\leq +0.09\%$   
using the current output  
simultaneously

### 3. Operation via Front Keys

#### 3.1. Power ON

Switching ON the supply powers up the device, the device initializes itself (display, load cell lines) and checks for any errors. The device status is indicated by the LED (red / green). For proper operation, the system should be warmed up for minimum 20 minutes. Initialization also takes place when loading the configuration through the serial port of the MP26/10 software.

#### 3.2. Status LED

The status LED indicates the status of the device. The status is indicated by the color of the light:

- Green indicates normal operation
- Red indicates limit value1 is active/ON
- Red blinking indicates instrument fault, configuration error

#### 3.3. Display

There are two display lines available in the device. The first line displays the process values. The second line displays the unit/error list /configuration settings / parameters.

Default display mode



Display of further operating levels



There are two modes of display available in the device based on the level in which the user is working.

**Default display mode:** This shows the processed weight value along with its unit.

**Operating mode:** This mode is used to set the configuration or parameters or display error or to calibrate the system

**Note:**

*In case of incorrect input values, signals dependent on input (e.g. Inp1, Inp2, display value, Out3) will also indicate FAIL.*

### 3.4. Key Pad

There are 3 keys on the device:

- Enter key
- Increment key
- Decrement key

#### 3.4.1. Enter Key Functionality

By using the enter key, different values can be loaded in display line 2.

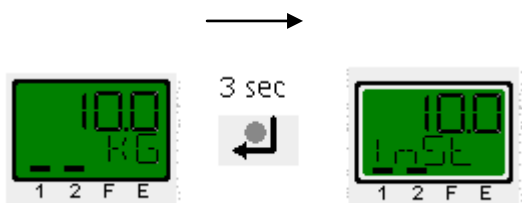

Pressing the enter key for more than 3 sec enables the device to move to further operating levels.

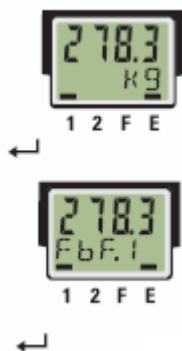

If an error has occurred in the device, it is indicated by a status bar over E; the error can be viewed by pressing the enter key. Pressing the enter key reveals further errors if present.

**Note:**

*If none of the keys are pressed in the operating mode, then the system returns to the default display mode.*

### 3.4.2. Increment & Decrement Key Functionality

#### Moving to Menu Levels

The increment / decrement keys can be used to move through different submenu levels. The increment key performs forward movement and the decrement key performs backward movement. This is shown in the operating levels.

#### Displaying min & max Values

The minimum and maximum input values are stored in the device and can be displayed by using decrement and increment keys in normal mode.

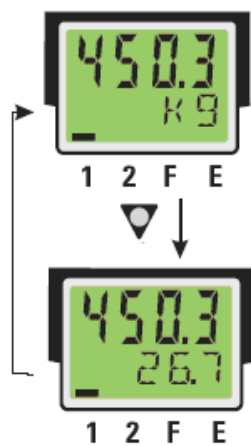

The minimum value is displayed as long as the decrement key is pressed.

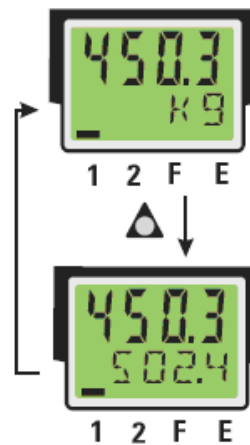

The maximum value is displayed as long as the increment key is pressed.

### 3.5. Configuration Levels

There are 3 configuration levels/modes available for the MP 26:

1. Normal Mode: displays the weight value along with its unit
2. Installation Mode: enables user to calibrate the system
3. Parameter Mode: enables user to set limit values & input values.
4. Configuration Mode: enables user to switch ON various functionalities and their associated settings
5. End: enables user to save and exit the operating levels

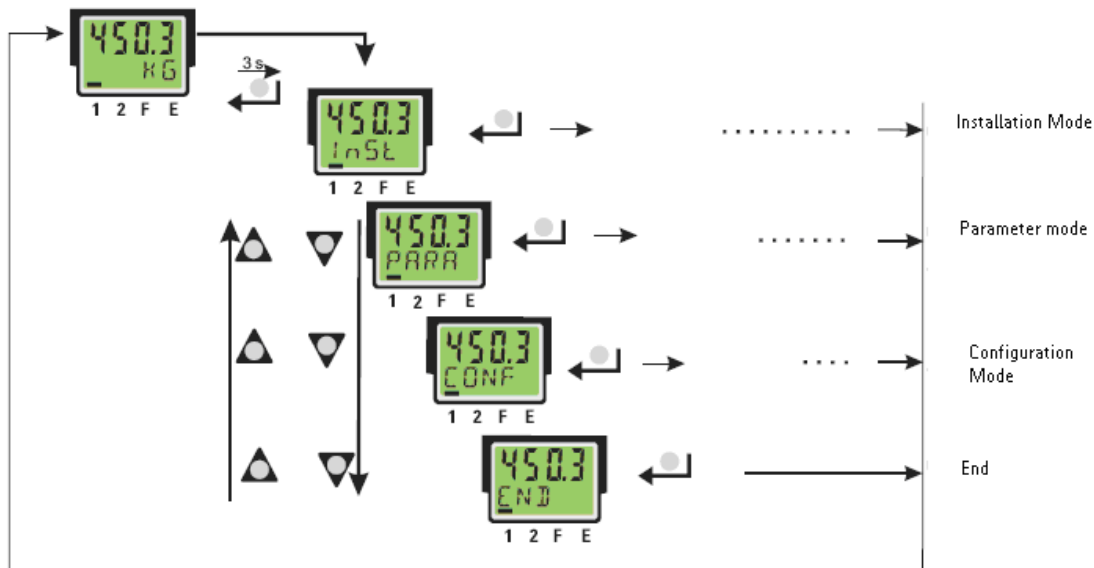

### 3.6. Calibration

Calibration of the scale must be followed by initial setting. After entering the prerequisites in the initial setting, the instrument can be calibrated for the given weight or value. Calibration can be carried out in two ways: one method is to use the MP26/10 tool and download the settings to the device. The other method is to use the device and its keys. Please refer to [Chapter 4](#) for more details.

### 3.7. Parameter and Configuration

#### 3.7.1. Device

##### Parameter

Parameter enables us to set to the input and limit values. The parameter for input and limit values are given below. Depending on the device version and set configurations, values may be hidden. The data that can be operated via the front panel are shown below

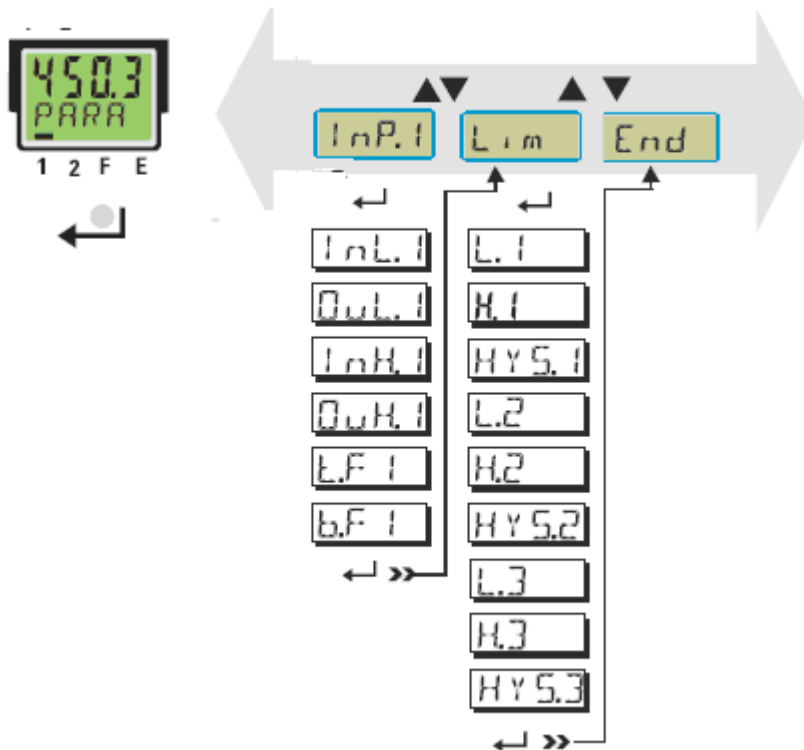

**Note:**

*This menu is only used to set limits. For normal settings, use the menu in Chapter 4.3.*

## Configuration

Depending on the device version and other configurations, the configuration data may be hidden. The data that can be operated via the front panel are shown below:

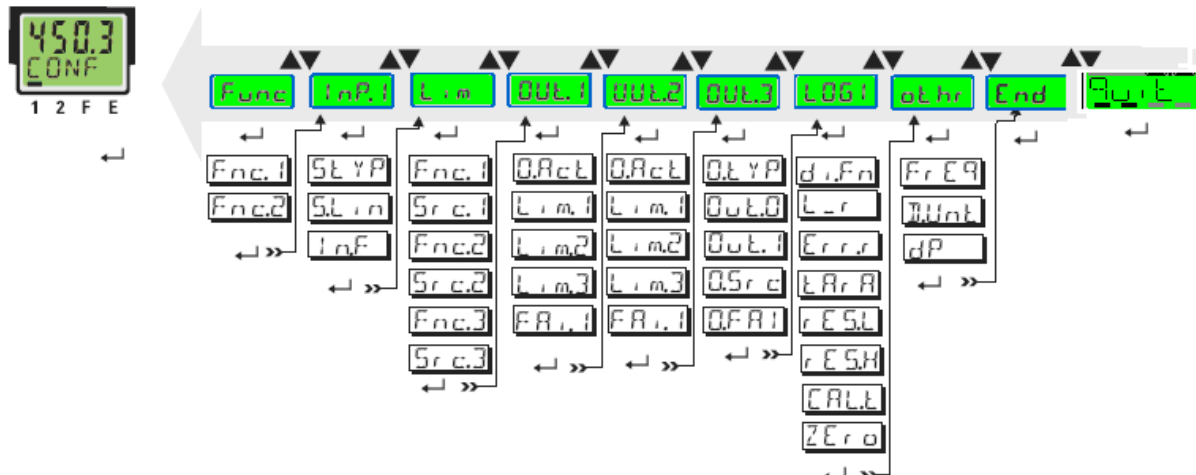

### 3.7.2. Zero Setting

Zero setting is used to zero the scale. It deletes the display of accumulated deposits that could falsify the measurement.

The zero set function is enabled through the configuration (**Func**→**Func1 = 1**).

Zero setting is achieved by

- Inputting a pulse [XXXX ms] on the digital input or
- Pressing a combination of keys or
- Setting a limit value
- Interface only (LOGI→ZErO)

For more details, please refer to [Chapter 4.4: Zero Setting](#)

### 3.7.3. Tare Setting

The tare function is used to tare the weight of the scale and the scale displays zero. Then, the net weight can be measured (net = gross – tare). The gross weight can be found by switching off the tare function.

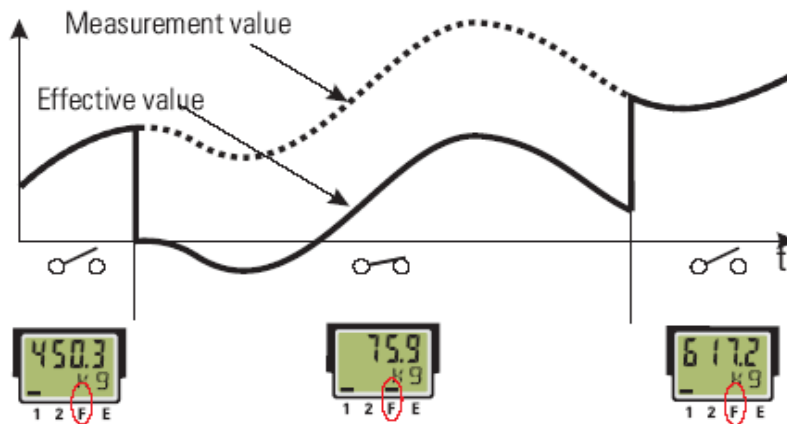

The bar symbol above F in the display line 2 indicates that tare is active. The tare function is enabled through the configuration (**Func**→**Func2 = 3**). Tare setting can be input in the device by

- Inputting a pulse [XXXX ms] on the digital input or
- Pressing a combination of keys or
- Setting a limit value
- Interface (LOGI→tArA)

For more details, please refer to [Chapter 4.5: Tare Setting](#)

### 3.7.4. Limit Value Processing

Max. three limit values can be configured for the outputs. Generally, both outputs **Out.1...Out.2** can be used for limit value or alarm signalling.

Several signals allocated to an output are linked by a logic **OR** function.

The signal to be monitored can be selected separately for each alarm in the configuration.

The following signals are available:

- Process value (displayed value)
- Measured value INP
- Zero adjustment

Each limit **Lim.1...Lim.3** has two triggering points H.n (Max) and L.n (Min) which can be switched off individually (parameter = **OFF**). The hysteresis HYS.n for each limit is adjustable, see Chapter 5.2.4.

### 3.8. Reset to Factory Settings

In the event of faulty configuration, the MP26 transmitter can be reset to the default manufacturer's state. The steps for resetting MP 26 are as given below:

1. Keep the increment and decrement keys pressed during power-on. After the display shows, wait for 1 sec until the display shows.
2. Then, press key increment to select **YES**.
3. Confirm factory resetting with enter and the copy procedure is started (display **COPY**).
4. Finally, the device restarts.

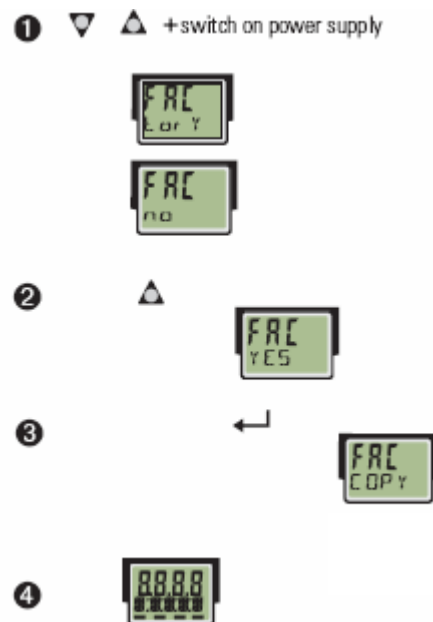

## 4. Calibration

### 4.1. General

Calibration of the scale must be followed by initial setting. After that the instrument can be calibrated for the given weight or value. The key calibration terms are as follows.

Name	Description	Value	Range
<b>InP.1 Input 1</b>			
InL.1	lower input value 1 [phys]	0.00	-1999...9999
OuL.1	lower output value 1 [phys]	0.0	-1999...9999
InH.1	upper input value 1 [phys]	10.00	-1999...9999
OuH.1	upper output value 1 [phys]	10.0	-1999...9999
t.F1	filter time 1 [s]	0.5	0.0...999.9
b.F1	filter bandwidth	5.0	0.0...9999

#### FSD (Full-scale Deflection, Max)

The full-scale deflection (FSD) determines the maximum weight that can be measured. The load cells perform best at 33 to 50 % of their full-scale capacity. Generally, it is recommended to set the calibration weight or FSD below this weight range.

This is set in OuH.1 whose default value is OFF.

#### Dead Load

The value of the unloaded scale/empty hopper is the dead load. The input voltage equivalent to this weight value is displayed/stored in percent. The default value is OFF.

During calibration, the user has to decide:

- To use the empty scale as dead load (normal case)
- To enter the dead load by value (if the scale cannot be unloaded or the value is known from previous calibration)

If the dead load has to be modified (due to an increase/decrease in weight of the empty scale), then the span must be modified accordingly. This is explained in the Chapter [Adjusting the Dead Load](#).

This is set in OuL.1 whose default value is OFF.

#### Span

The span indicates the equivalent input voltage between dead load and the scale FSD (full-scale deflection); i.e. the difference between the load cell output at maximum load,  $D_{max}$ , and load cell output at minimum load,  $D_{min}$ .

### Overload

The device is able to generate an alarm signal on overload. For this signal to assert the limits, the values should be entered suitably in terms of their physical weight values.

Generally, this is set as:

Alarm (Signal ON) = FSD (Max Load) + overload (Hysteresis)

Overload = 9\*d

Display division (d) = max load / scale interval.

The scale interval may be 1 or 0.1 or 0.01 or 0.001 based on the decimal point set calibration.

### Low Pass Filter and Bandwidth

A first order mathematical low pass filter with adjustable time constant and bandwidth is built in.

The bandwidth is the adjustable tolerance around the measured value within which the filter is active. Measurement value changes in excess of the adjusted bandwidth are not filtered.

This is set in b.F1.

The input signal display is delayed. The higher the value, the slower the display.

This is set in t.F1

## 4.2. Calibration

Calibration can be conducted in two ways: the easiest way is to use the MP26/10 tool and download the settings to the device. The other way is to use the device. Calibration is conducted as follows:

### Initial Setting:

Phase 1: Disable tare and special linearization

Phase 2: Configure the initial settings relating to input and output.

### Calibration

Calibration can be done in two ways

- Using front keys or
- The MP26/10 tool.

Each way contains two methods to calibrate the device

- Calibration by load
- Calibration by value

### 4.3. Calibration via the Device

Calibration via the device is possible by pressing a combination of keys. The calibration procedure is done by making the initial settings, then calibrating the device by load or value. An overview of the calibration field is presented below.

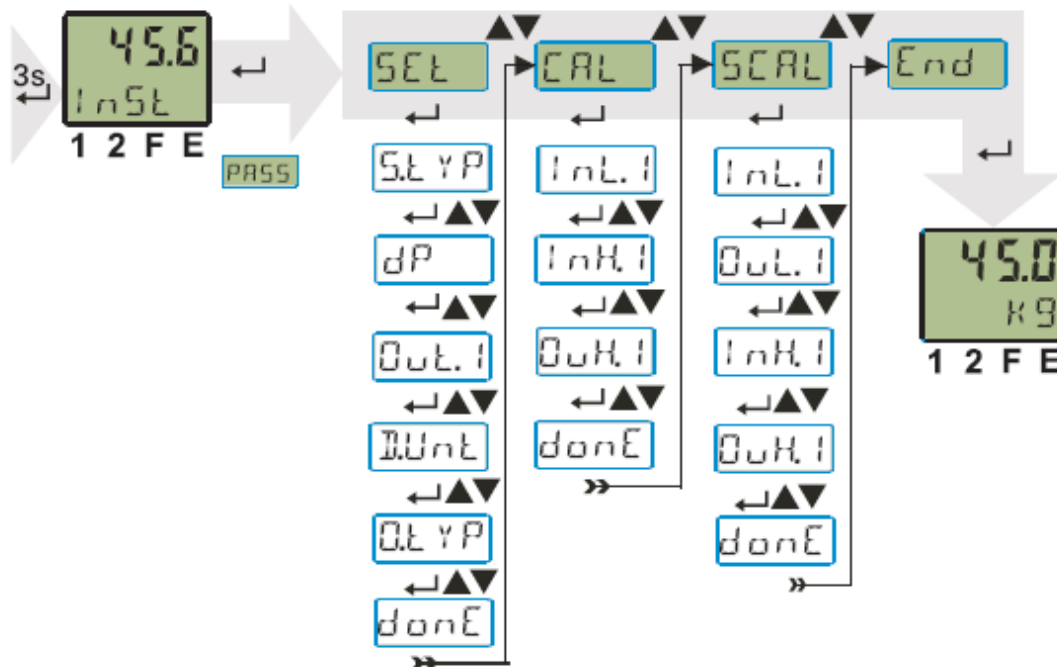















Press  for more than 3 sec, this will lead to InSt mode, where installation and calibration can be done. The top-level menus in this mode are Set, Cal, Scal and End. In the SET menu, initial settings to the device can be entered. In the CAL menu, calibration by weight can be performed. In the SCAL menu, we calibrate by value. The End menu enables us to exit the InSt mode and return to the normal weight display mode.

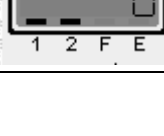

**Note**

*Throughout the procedure, wherever values can be entered the display alternates between menu level and value.*

### 4.3.1. Initial Setting via the Device





#### Disable Tare & Special Linearization





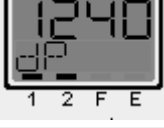
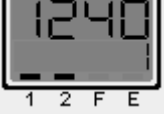

Step	Display Line 2	Operation	Description
1.		Press  for more than 3 sec to display InSt.	If the initial settings are made earlier, then calibration mode is activated directly.
2.		Press  to move to COnF to set the configuration.	In the configuration mode, disable the tare function and special linearization.
3.		Press  to move to FunC.	
4.		Press  to move to FnC.2.	Move to tare function.
5.	  	Now the display alternates between FnC.2 and value. Use  or  and set the value to zero. Next, press  . Now, the display shows dOnE and shows Inp.1.	Deactivate the tare function by setting FnC.2 to zero.
6.		Press  <b>twice</b> to move to S.Lin.	

Step	Display Line 2	Operation	Description
7.		<p>Now, the display alternates between S.Lin and value. Use ▲ or ▼ and set the value to zero.</p> <p>Press ↵ twice to move to Lim.</p>	Disable the special linearization.
8.		Use the ▲ or ▼ and move to the End	
9.		Press ↵ to return to normal display.	

### Initialize Inputs & Outputs

In the process of setting the values below, the display alternates between the corresponding menu level and value. Set the value using ▲ or ▼, then press ↵. After you press ↵, the value is set in the corresponding menu level and the display moves to the next menu level.

Step	Display Line 2	Operation	Description										
1.		Press ↵ for more than 3 sec. The display shows InSt.	Entering calibration InSt mode										
2.		Press ↵ to move to SET	To perform installation										
3.		Press ↵ to move to S.tYP	To perform initial settings for input and output										
4.	 	Set the load cell sensor type using ▲ or ▼, then press ↵ to set the value and move to dP.	<table border="1"> <thead> <tr> <th>Value</th> <th>Description</th> </tr> </thead> <tbody> <tr> <td>60</td> <td>0.5 mV/V</td> </tr> <tr> <td>61</td> <td>1 mV/V</td> </tr> <tr> <td>62</td> <td>2 mV/V</td> </tr> <tr> <td>63</td> <td>4 mV/V (the selection for sensors with 3.33 mV/V)</td> </tr> </tbody> </table>	Value	Description	60	0.5 mV/V	61	1 mV/V	62	2 mV/V	63	4 mV/V (the selection for sensors with 3.33 mV/V)
Value	Description												
60	0.5 mV/V												
61	1 mV/V												
62	2 mV/V												
63	4 mV/V (the selection for sensors with 3.33 mV/V)												
5.	 	Set the decimal point using ▲ or ▼, then press ↵ to set the value and move to Out.1	<table border="1"> <thead> <tr> <th>Value</th> <th>Description</th> </tr> </thead> <tbody> <tr> <td>0</td> <td>No decimal points</td> </tr> <tr> <td>1</td> <td>1 decimal point</td> </tr> <tr> <td>2</td> <td>2 decimal point</td> </tr> <tr> <td>3</td> <td>3 decimal point</td> </tr> </tbody> </table>	Value	Description	0	No decimal points	1	1 decimal point	2	2 decimal point	3	3 decimal point
Value	Description												
0	No decimal points												
1	1 decimal point												
2	2 decimal point												
3	3 decimal point												













Step	Display Line 2	Operation	Description												
6.	 	Set the analog output value using ▲ or ▼, then press ↵ to set the value and move to D.Unt	Enter the weight value for which 100% analog output has to be generated. Range: -1999 to 9999												
7.	 	Set the display unit using ▲ or ▼, then press ↵ to set the value and move to O.tYP	<table border="1"> <thead> <tr> <th>Value</th> <th>Display unit</th> </tr> </thead> <tbody> <tr> <td>19</td> <td>kg</td> </tr> <tr> <td>20</td> <td>g</td> </tr> <tr> <td>21</td> <td>t</td> </tr> <tr> <td>22</td> <td>Text of phys. unit/ preset via MP26/10</td> </tr> <tr> <td>23</td> <td>lb</td> </tr> </tbody> </table>	Value	Display unit	19	kg	20	g	21	t	22	Text of phys. unit/ preset via MP26/10	23	lb
Value	Display unit														
19	kg														
20	g														
21	t														
22	Text of phys. unit/ preset via MP26/10														
23	lb														
8.	 	Set the analog output type using ▲ or ▼, then press ↵ to set the value and move to donE	<table border="1"> <thead> <tr> <th>Value</th> <th>Output type</th> </tr> </thead> <tbody> <tr> <td>1</td> <td>0 ... 20 mA continuous</td> </tr> <tr> <td>2</td> <td>4 ... 20 mA continuous</td> </tr> <tr> <td>3</td> <td>0...10V continuous</td> </tr> <tr> <td>4</td> <td>2...10V continuous</td> </tr> </tbody> </table>	Value	Output type	1	0 ... 20 mA continuous	2	4 ... 20 mA continuous	3	0...10V continuous	4	2...10V continuous		
Value	Output type														
1	0 ... 20 mA continuous														
2	4 ... 20 mA continuous														
3	0...10V continuous														
4	2...10V continuous														
9.		Press ↵ to save it and move to another menu level.	After pressing ↵, the display shows CAL. If you want to move to the specific menu level for further processing, press ↵ when the display shows that menu level. Otherwise, use the up or down arrow key to move to CAL→SCAL→End. Pressing ↵ in the End menu level to exit and return to normal weigh mode/ display mode.												

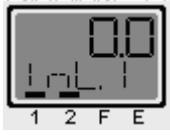

### 4.3.2. Calibration by Load

Calibration by load can be done directly in calibration mode if the initial settings were previously configured. Alternatively, configure the initial settings as explained above and then go to calibration mode.

Nevertheless, it is recommended to configure the settings before calibration.

Deactivate the tare function or tare to zero for effective calibration. If tare is not set to zero, after calibration it will display a weight, that is not equal to the calibrated weight. It will be a weight reduced by the tare value.

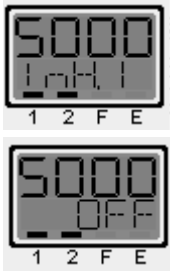
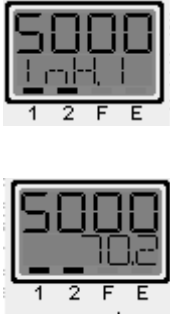
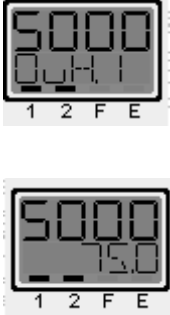
Step	Display Line 2	Operation	Description
1.		Press  for more than 3 sec it will display InSt. Press  to go to SEt. Use  or  and move to CAL.	If the initial settings have been configured earlier then go directly to calibration mode.
2.		Press  to move into calibration mode. Then the display shows InL.1	Here calibration by weight can be performed.
3.	 	In this menu level the display toggles between OFF and InL.1.	
4.	 	Now Set the dead load.  Use  or  to enable the measured value. Then press  .  Now the display moves to InH.1	Set the dead load by removing any weight apart from dead load from the system  XXXX value only shows the measured value in percentage. This finishes setting the dead load

Step	Display Line 2	Operation	Description
5.		<p>In this menu level, the display toggles between InH.1 and OFF.</p> <p>Now calibrate the system for standard weight.</p>	Load the system with the standard weight
6.		<p>Use ▲ or ▼ to enable the measured value. Then press ↵. Now the display moves to OuH.1</p>	XXXX value This only shows the measured value in percentage.
7.		<p>Use ▲ or ▼ and set the calibrated weight.</p> <p>Then press ↵. The display shows dOnE and moves to SCAL</p>	Set the calibrated weight in the system.
8.		<p>Use ▲ or ▼ and move to End. Then press ↵ to save the settings and return to normal display mode.</p>	

**Note:**

Any previously realized zero setting (function 1) is deleted.

The InL.1 and InH.1 values are displayed with a resolution of 4 digits. However, the InL.1 and InH.1 values stored during calibration are stored with full resolution.















On pressing the ▲ or ▼ the display unit is incremented/decremented, based on the pressing interval (1,2..sec) the unit values are shifted in counts of 1 at various display positions.





















In the above process if the ▲ or ▼ is not pressed then

- While setting dead load the device sets InL.1 = 0 % correspondingly OuL.1 = 0
- While setting calibrated load/FSD the device sets InH.1 = 100% correspondingly OuH.1 = Out.1

### 4.3.3. Dead Load Correction

The dead load can be adjusted without the need of an entire calibration. The steps are explained as follows.

Step	Display Line 2	Operation	Description
1.	kg 	Press  more than 3 sec it will display InSt. press  to go to SEt. use  or  and move to SCAL.	If the initial settings have been configured earlier then we can directly go to Weighing mode.
2.	SCAL 	Press  to move into calibration by mode. Now the display shows InL.1	Here calibration by value can be performed.
<b>Note down the previous Calibration values</b>			
3.	InL.1  	Note down the InL.1 value consider this as PreL.  Press  twice to go to InH.1	In this menu level, the display alternates between InL.1 and the set value. The value displayed here shows the previous calibration's dead load. Note the value.
4.	InH.1  	Note down the InH.1 value consider this as PreH.  Press  until the display shows dOnE and moves to End. Press  to go to normal display mode.	In this menu level, the display alternates between InH.1 and set value. The value displayed here shows the previous calibration's max value.













Step	Display Line 2	Operation	Description
<b>Adjusting the Dead Load Calibration</b>			
5.	kg 	Press  for more than 3 sec to display InSt. Press  to go to SEt. Use  or  and move to CAL	After finishing the full-scale calibration, the dead weight is shown in display1.
		Press  to move into calibration mode. Then, the display shows InL.1	Here, calibration can be adjusted.
	 	In this menu level, the display alternates between OFF and InL.1.	
	 	Now set the dead load. Use  or  to activate the measured value. Note down the measured value as Ctl. Press  .  Now the display moves to InH.1. Press  until you reach SCAL→InH.1	Set the dead load by removing any weight apart from the dead load from the system  XXXX only shows the measured value in percent. This finishes setting the dead load.
	SCAL→InH.1  	Set the calibration weight using  or  .  Then, press  until End is reached.	Set the adjusted calibration value as $CH = (PreL - Ctl) + PreH$ . Afterwards, the dead load is adjusted to the current value.









#### 4.3.4. Calibration by Value

Calibration by value can be done in an indirect way. Switch to SCAL mode if the initial settings have been configured previously or configure the initial settings as explained above and then switch to SCAL mode.

An example for calibration by value is given in Chapter 4.6. Please refer to it for detailed information.

Calibration by value is done indirectly. It is a theoretical calibration. The calibration is done based on the assumption that the dead load is zero. From this, knowing the dead load weight, adjust the zero point to the dead load. The calibration point is shifted accordingly to the zero point shifts, thereby calibrating the system to its dead load weight.

Step	Display Line 2	Operation	Description
1.	kg 	Press  for more than 3 sec to display InSt. Press  to go to SEt. Use  or  and move to SCAL.	If the initial settings have been configured earlier, then, go directly to SCAL mode.
2.	SCAL 	Press  to move to calibration by value. Now, the display shows InL.1.	Here, calibration by value can be performed.
<b>Calibration for standard weight</b>			
3.	InL.1   	Set the dead load to zero using the  or  arrow key. Then press  .  Now the display shows OuL.1.	In this menu level, the display alternates between InL.1 and set value. Enter zero percent as dead load.



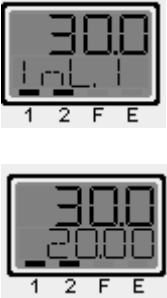
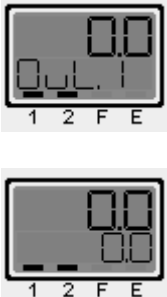
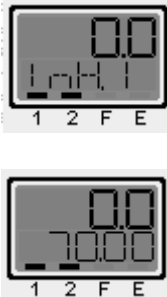
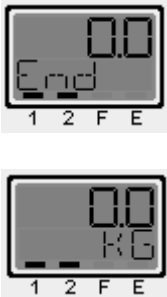



Step	Display Line 2	Operation	Description
4.	OuL.1  	Use ▲ or ▼ and set zero. Then press ↵.	In this menu level, the display alternates between OuL.1 and zero. Setting 0% corresponds to zero weight.
5.	InH.1  	Setting the calibration weight.  Use ▲ or ▼ and set its Pspan percentage. Then press ↵.	In this menu level, the display alternates between InH.1 and percent value.  The span percentage is given as $Pspan [\%] = (\text{calibration weight} * 100) / \text{total load cell capacity}$ .
6.	OuH.1  	Use ▲ or ▼ and set the calibration weight.  Then press ↵. The display shows dOnE and moves to End. Press ↵ to go to normal display mode.	Set the full-scale deflection in the system.
<b>Dead Load Calibration</b>			
7.	kg 	Press ↵ for more than 3 sec to display InSt. Press ↵ to go to SEt. Use ▲ or ▼ and move to SCAL	After finishing the full-scale calibration, the dead weight is shown in display1.
8.	SCAL 	Press ↵ to move to calibration by value.  Now the display shows InL.1.	Here, calibration by value can be performed

Step	Display Line 2	Operation	Description
9.	InL.1 	Set the set dead load in percent using ▲ or ▼. Then press ↵	In this menu level, the display alternates between InL.1 and zero.  The dead load in percent is given by $P_{dead} [\%] = (\text{dead load} * 100) / \text{max. capacity load cell}$ where the dead load is the weight displayed in display line 1.
10.	OuL.1 	Use ▲ or ▼ and set to zero. Then press ↵	In this menu level, the display alternates between OuL.1 and zero.
11.	InH.1 	Use ▲ or ▼ and adjust the upper calibration point.  Then, press ↵ <b>twice</b> . The display shows dOnE and moves to End.	In this menu level, the display alternates between InH.1 and zero.  The adjusted upper calibration point is given by $InH.1 = P_{span} + P_{dead}$
12.	End 	Press ↵.	By pressing ↵, the display saves all parameters, returns to weight display mode and shows zero on the display line 1









#### 4.4. Zero Setting

The zero setting is used to zero the scale. It voids the residual weight on the scale which cannot/may not be removed immediately.

The procedure for setting zero is:

1. Press  for more than 3 sec, it leads to Inst
2. Use  or , move to COnF and press the  key
3. It will display FUnC. Press the  key.
4. Use  or  to set the FnC.1 to 1.

Function	Value	Description
FnC.1		Function 1
	0	No function
	1	Zero setting

5. Press  to move to done and InP.1.
6. Use  or , move to LOGI and press .
7. Press  until ZErO is reached.
8. Use  or  to set the logic required for zeroing the scale and confirm with  key.









ZErO		Zero setting
	0	Interface only
	2	di1 switches
	7	Limit 1 switches
	8	Limit 2 switches
	9	Limit 3 switches
	10	Enter/Inc keys switch
	11	Enter/Dec keys switch

9. It will display dOnE and move to Othr. Use  or  and move to End and confirm with .









## 4.5. Tare Setting

The tare function is used to tare the weight on the scale. The scale displays zero. Then, the net weight can be measured (net = gross – tare). The gross weight can be found by switching off the tare function.



The procedure for setting the tare is:

1. Press the  for more than 3 sec. It will lead to Inst.
2. Use  or  to move to COnF and press  key.
3. It will display FUnC. Press the  key.
4. Press  key to move to FnC.2 and use  or  to set it to 1.

Function	Value	Description
FnC.2		Function 1
	0	No function
	1	Tare setting

1. Press  to move to done and InP.1.
2. Use  or  to move to LOGI and press .
3. Press  until tArA is reached.
4. Use  or  and set the logic required for tarring the scale and confirm with the  key.

tArA		Tare function (function must be activated (CONF /FUNC / Fnc.2= 3))
	0	Interface only
	2	di1 switches
	7	Limit 1 switches
	8	Limit 2 switches
	9	Limit 3 switches
	10	Enter/Inc keys switch
	11	Enter/Dec keys switch

5. dOnE is displayed. Move to rESL. Press  to move to Othr. Use  or  to move to End and confirm with .

## 4.6. Example: Calibration by Value

For example, consider a load cell with 150 kg capacity and a sensitivity of 2mV/V. The voltage between  $V_+$  and  $V_-$  is 10 V. We want to calibrate the system for the 75-kg full-scale capacity plus an unknown dead load.

Assumption:

No load produces 0 mV which is 0%, so enter  $InL.1 = 0$  (entry = %),  $OuL.1 = 0$  (display = kg)

A full load produces 20 mV 10 V, i.e. 150 kg corresponds to 20 mV which is 100%.

$$\begin{array}{lllll} \text{output signal} = & \text{power supply} * & \text{sensitivity of load cell} & & (\text{@ max. capacity}) \\ 20 \text{ mV} = & 10 \text{ V} * & 2 \text{ mV/V} & & (\text{@ 150 kg}) \quad 100 \% \end{array}$$

### Solution:

We want the system to be calibrated for 75 kg.

The first step is to determine the  $Pspan$  [%] assuming no dead load is present in the system:

Set  $InL.1 = 0$ ,  $OuL.1 = 0$ .

$Pspan$  [%] = (full scale \* 100) / (total capacity of load cell).

$Pspan$  [%] = (75 \* 100) / 150 produces  $Pspan = 50$

Enter  $InH.1 = 50$  (entry = %) and  $OuH.1 = 75$  (display = kg)

Save the data to the device (Press  to move to end).

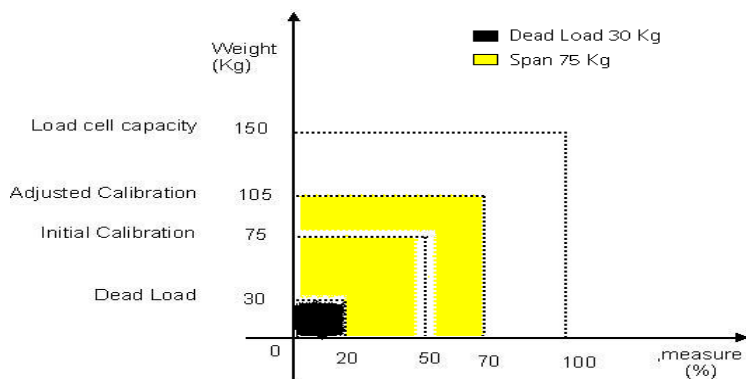

Now, the device shows the dead load as a weight value as xxxx kg.  
If the device shows 30 kg, dead load = xxxx = 30.

The second step is to adjust the dead load and calibration point

$Pdead$  [%] = (dead load \* 100) / (max. capacity of load cell).

$Pdead$  [%] = (30 \* 100) / 150 = 20

Set  $InL.1 = Pdead = 20$  (entry = %);

$OuL.1 = \text{dead Load} = 0$  (display = kg);

$InH.1 = 50 + Pdead = 70$  (entry = %);

$OuH.1 = 75$  (display = kg)

Save the data to the device (Press  to move to end).











Now the device has adjusted its dead load and the display shows Zero.

## 4.7. Setting the Low Pass Filter and Bandwidth

### Filter Time

A first order mathematical low pass filter with adjustable time constant and bandwidth is built-in. The time constant of the filter must be greater than zero. Normally higher values result in good suppression of disturbances, but in an increased delay of the input signals, i.e. the weight updating on the display will be slower.

This time constant is set in t.F1 as follows:

1. Press  for more than 3 sec.
2. It will move to Inst  or  and go to Param and press .
3. It will display InP.1, now press  until you reach t.F1.
4. Using  or , set the desired time constant (ms) whose range is 0.0....999.9, default is 5.0 ms, then press .
5. Press  until end is reached.
6. Press  to go to normal display mode.





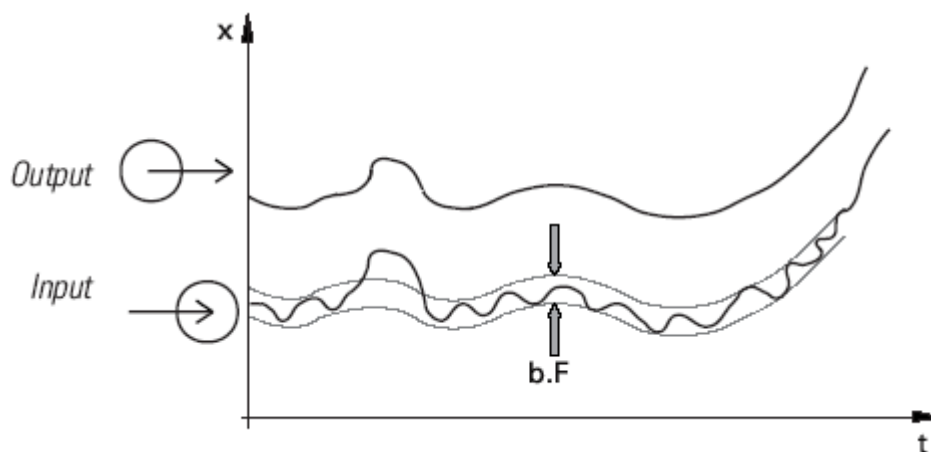





### Bandwidth

The bandwidth is the adjustable tolerance around the measured value within which the filter is active.



Measurement value changes in excess of the adjusted bandwidth are not filtered.

The bandwidth is set in b.F1 as follows:

7. Press  for more than 3 sec.
8. It will move to Inst  or  and go to PArA and press .
9. It will display InP.1, now press  until you reach b.F1.
10. Using  or , set the desired bandwidth whose range is 0.0 .... 999.9, default is 5.0 then press .
11. Press  until end is reached.
12. Press  to go to normal display mode.

## 5. Configuring Outputs

### 5.1. Overview

Limit values can be configured to generate outputs at Out.1, Out.2, Out.3 ports. Several signals allocated to output are linked by OR logic.

The device can generate the output based on

- Process value (displayed value)
- Measured value INP
- Zero adjustment

### 5.2. Configuring OUT.1 and OUT.2









Three signal limits are available with the device. Each limit value consists of a switch-on and a switch-off point for definition of a hysteresis. The three pairs of values must be entered according to the same principle. The limit values refer to the corresponding source.

This option can be used to obtain information on the filling status of a hopper and to generate a signal. Each limit has three weight variables (lower limit, upper limit, and hysteresis).







The procedure for configuring the outputs 1 and 2 via the device and tool are similar and explained as below.

### 5.2.1. Define the Limits

The first step in limit value processing is to set or unset the source of limits. This can be set in the configuration menu.

1. Press  for more than 3 sec. It leads to Inst.
2. Use  or  and move to COnF and press  key.
3. The display now shows FUnC. Press  key and set the function using  or  if required then press  key.

Function	Value	Description
FNC.1		Function 1
	0	No function
	1	Zero setting
FnC.2		Function 2
	0	No function
	3	Tare

4. After setting the function, the display moves to InP.1. Use the  or  key to go to Lim and press  key.
5. Set the required type of functionality and its corresponding source for limited processing using the  or  key and confirm with  key.

Functional Limit	Value	Description
Fnc.1 (Fnc.2) (Fnc.3)		Function of limit 1 (2, 3)
	0	Switched off
	1	Measured value
	2	Measured value monitoring + alarm status latch. Alarm signal is generated when the stored limit value is exceeded. An activated signal remains switched ON until it is manually re-set. A stored limit value can be reset via error list or a digital input (→ LOGI/ Err.r).
Src.1 (Src.2) (Src.3)		Source of limit 1 (2, 3)
	0	Process value (displayed value)
	3	Measured value INP M
	12	Zero offset (difference between the calibrated zero and the value at the time of zero setting)

### 5.2.2. Configure the Output

6. Use ▲ or ▼ to move to the required Out.x and press ↵ key.
7. Set the parameters below using ▲ or ▼, then press ↵ key to confirm and move to the next menu/sub menu.

Name	Value	Description
O.Act	Direction of operation OUT1	
	0	Direct / normally open
	1	Inverse / normally closed
Lim.1	Signal limit 1 (Result of comparison of limit 1 values with actual weight)	
	0	Not active
	1	Active
Lim.2	Signal limit 2 (Result of comparison of limit 2 values with actual weight)	
	0	Not active
	1	Active
Lim.3	Signal limit 3 (Result of comparison of limit 3 values with actual weight)	
	0	Not active
	1	Active
FAi.1	Signal INP fail	
	0	Not active
	1	Active

8. After configuring the required outputs, use ▲ or ▼ to move to End and press ↵ key.

### 5.2.3. Setting Values for Limit Processing

9. Press the ↵ key for more than 3 sec and go to Inst
10. Use ▲ or ▼ to go to PArA and press ↵ key
11. Use ▲ or ▼ and move to Lim
12. Set the limit values based on the output requirement using ▲ or ▼ and confirm with the ↵ key

Limits	Range	Description
L.1	-1999...9999	Display value lower limit (L.1 < -1999 then L.1 is off )
H.1	-1999...9999	Display value upper limit (L.1 < -1999 then H.1 is off )
HYS.1	0...9999	Hysteresis for limit value 1
L.2	-1999...9999	Display value lower limit (L.2 < -1999 then L.1 is off )
H.2	-1999...9999	Display value upper limit (L.2 < -1999 then H.1 is off )
HYS.2	0...9999	Hysteresis for limit value 2
L.3	-1999...9999	Display value lower limit (L.3 < -1999 then L.1 is off )
H.3	-1999...9999	Display value upper limit (L.3 < -1999 then H.1 is off )
HYS.3	0...9999	Hysteresis for limit value 3

Limit value processing is as shown below.

### 5.2.4. Operating Principle: Limit Value Processing

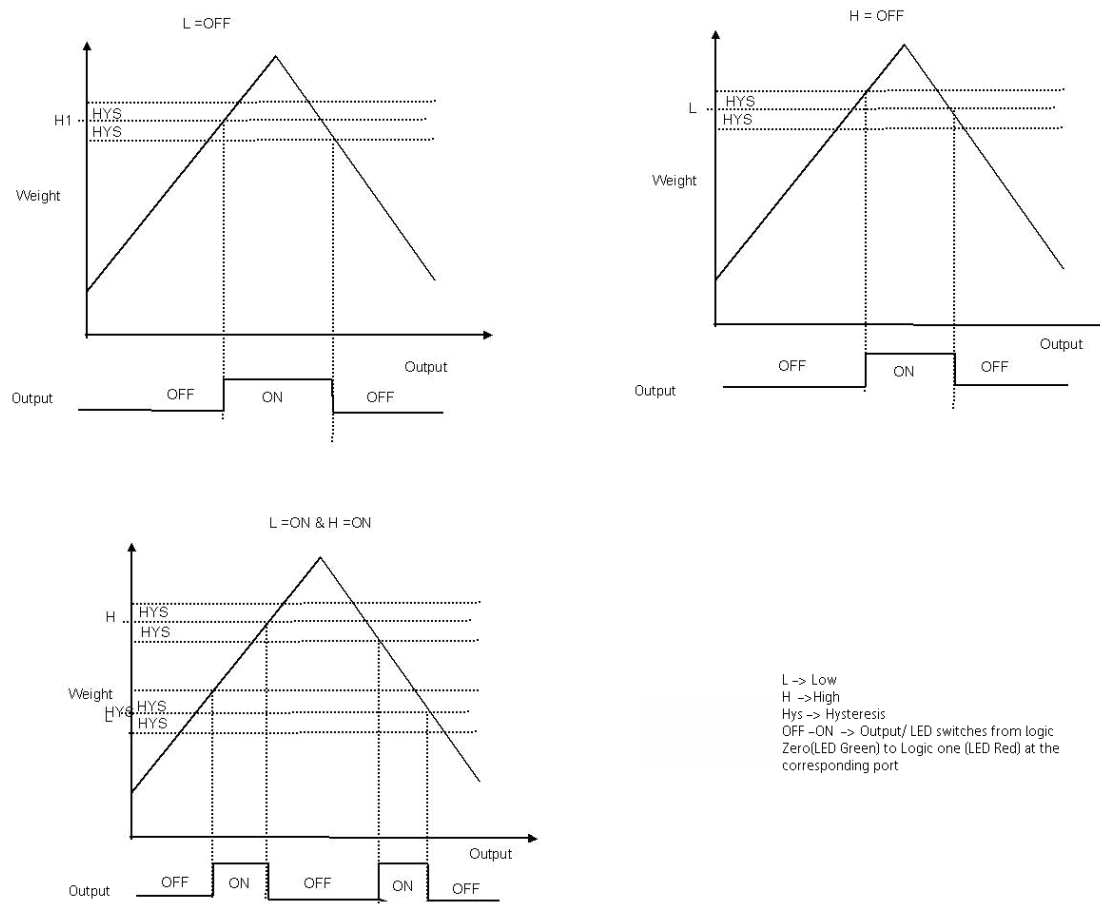

**Note:**

The limit values have to be entered in units of weight.

If  $conf \rightarrow out.n \rightarrow 0$ . Act  $\rightarrow 1$ . (inverse), output will be generated which is inverted to the figure shown above.

With measurement value or signal change with latch selected (ConF / Lim / Fnc.x = 2, 4), the alarm relay remains set until it is reset in the error list.

This alarm can be reset via:

di1 or

a limit value or

a key combination.









For this, reset the error list.

After power on or an engineering download, a used input filter has an effect on the gradient of the input signal. Therefore, valid alarm monitoring can only be processed after a certain rise over time. This time depends on the value of the filter time constant  $t.F$ . For  $t.F = 0$ , the monitoring results are valid immediately.

### 5.3. Output Out.3 (Analog)

The device can be configured to take the output measure as constant voltage or current.

The procedure for configuring Out.3 is:

1. Press the  more than 3 sec. It will leads to Inst
2. Use  or  to move to COnF and press  key
3. Use  or  to move to Out.3
4. Set the required values using  or  and confirm with the  key

Name	Value	Description
O.tYP		Signal type OUT3
	1	0 ... 20 mA continuous
	2	4 ... 20 mA continuous
	3	0...10V continuous
	4	2...10V continuous
Out.0	-1999...9999	Scaling of the analog output for 0 % (0/4 mA or 0/2 V) (Out.0 =entered_value0 =0% )
Out.1	-1999...9999	Scaling of the analog output for 100 % (20 mA or 10 V) (Out.1 =entered_value1 = 100% )
O.Src		Signal source for analog output OUT3
	3	Process value (scaled and corrected value, i.e. displayed value)
	7	Measured value (raw value of bridge signal)
O.FAI		Fail behavior
	0	Scale up
	1	Scale down

5. After the settings are configured, the display shows LOGi . Using  or , move to End and confirm with the  key.

#### 5.3.1. Analog Output Configuration Example

For example, the device is calibrated for 50% of its measurements in 5000 g, O.typ = 2 (4 to 20 mA), Out.0 = 500, Out.1 = 2500, O.src = 7, O.FAI = 0

Now, the analog output generation for the weight on the system is

-357 g	0 mA
350 g	2.8 mA
500 g	4.0 mA
1500 g	12.015 mA
2500 g	20 mA
3000 g	24.039 mA
EEEE	25.128 mA

**Note:**

*Out.0 and Out.1 have to be entered as weight values.*

*In case of a weight greater than the Out.1, the device produces 12 V or 25 mA*

*In case of a weight lower than the Out.0, the device produces 0V or 0 mA/<4 mA*

*If there is an input value error, then the output behavior for this can be determined using O.FAI.*

*The smaller the span, the higher the effect of input variations and resolution.*

*Using current and voltage output in parallel is possible only in galvanically isolated circuits.*

## 6. Possible Errors & Remedies

### 6.1. General

In this chapter, the possible errors and their remedies are discussed.

An error in the device is identified by a marker over the E in display line 2 as shown in the figure. Errors can be viewed by pressing the  key.

If there are more errors, they can be viewed by successively pressing the enter key.



For example, if an alarm is still pending, i.e. unless the error cause was removed, the bar over E blinks.

E- Display	Description	Remedy
Blinks	Alarm due to existing error	<ul style="list-style-type: none"> <li>- Determine the error type in the error list via the error number</li> <li>- Remove error</li> </ul>
<b>on</b>	Error removed, Alarm not acknowledged	<ul style="list-style-type: none"> <li>- Acknowledge alarm in the error list by pressing the up or down key</li> <li>- The alarm entry is deleted</li> </ul>
<b>off</b>	No error, all alarm entries deleted	

## 6.2. Error List

Error	Description	Cause	Possible Remedy
E.1	Internal error, cannot be corrected	E.g. defective EEPROM	Contact Service. Return device to manufacturer
E.2	Internal error, resettable	E.g. EMC trouble	Keep measuring and supply cables separate. Protect contactors by means of RC snubber circuits.
E.3	Configuration error, resettable	Missing or faulty configuration	Check interdependencies of configurations and parameters
E.4	Hardware error	Code number and hardware not identical	Contact Service
FbF.1	INP*) sensor break	Defective sensor	Replace INP sensor
		Wiring error	Check INP connection
		Overshoot	Change measuring range
POL.1	INP*) polarity error	Wiring error	Change INP polarity
Lim.1 Lim.2 Lim.3	Latched limit value alarm 1/2/3	Adjusted limit value 1/2/3 exceeded	Check process

**Note:**

\*) "FAIL" is shown on the process value display.

Latched alarms Lim1/2/3 (E-element displayed) can be acknowledged, i.e. reset via digital alarm di1.

If an alarm is still pending, i.e. unless the error cause was removed (E display blinks), latched alarms cannot be acknowledged and reset.

Error status	Significance	
2	Pending error	Change to error status 1 after error removal
1	Stored error	Change to error status 0 after acknowledgement in error list 0
0	No error/ message	Not visible, except during acknowledgement

If sensor errors are not on the error list any more after error correction without manual reset in the error list, suppression via MP26/10 is possible by setting ILat.

CONF → othr → ILat → 1 (blocked)

This setting has no effect on limit values Lim.1...3 configured for storage.

### 6.3. Detection and Display of Sensor and Wiring errors

- 1) Break in the supply measuring or sense lines: "FAIL" is displayed on the process value display and "FbF.1" in the error list.  
(A substitute value (In.F) can be entered in the event of a sensor error.)
- 2) Wrong polarity of supply, sense and input signal lines: "FAIL" appears on the process value display and "POL.1" in the error list. Detection of wrong polarity of sense takes place during instrument start-up.  
Subsequent correction of the sense wiring is detected only after instrument re-start (i.e. the instrument must be switched off and on again.)
- 3) Short circuit of supply and sense lines ==> behavior as with break in supply lines: "FAIL" appears on the process value display and "FbF.1" in the error list.
- 4) Short circuit of measuring lines: measuring signal = 0
- 5) Overshoot of measurement input: "FAIL" appears on the process value display and "FbF.1" in the error list.

## 7. Technical Data

### 7.1. Inputs

#### 7.1.1. Input M

Resolution:	>19 Bit
Decimal point:	0 to 3 decimals
Digital input filter:	adjustable 0.0 to 999.9 s
Scanning cycle:	50 ms
Linearization:	31 Segments, adaptable with Engineering tool MP 26
Measurement value correction:	2-point
Limiting frequency	1.7 Hz
Measurement value correction:	Sensor break, short circuit and polarity
Connection technology:	4-wire bridge
	6-wire bridge (Sense line)
Input range Span start, span end	any, within measuring range
Scaling	any, -1999 to 9999
<b>Measurement span</b>	
Slope/sensitivity	0.5 mV/V
	1 mV/V
	2 mV/V
	4 mV/V

#### 7.1.2. Digital Input DI1

<b>Operation as Contact input</b>	
Connection of a potential-free contact that is suitable for switching 'dry' circuits.	
Switched voltage:	5 V
Current:	0.5 mA
<b>Operation as Control input</b>	
Configurable as direct or inverse switch or push button!	
Functions:	Operation disabling, reset of stored alarms and the min/max indicator (slave pointer), the integrator, enabling the tare function, Sample&Hold amplifier function, Cal-Test , and zero setting.

## 7.2. Outputs

### 7.2.1. Relay Outputs OUT1, OUT2

Contact type:	2 normally open with common contact connection
Max. contact rating:	500 VA, max. 250 V, max. 2 A at 48...62 Hz, ohmic load
Min. contact rating:	6 V, 1 mA DC
Switching cycles (electrical):	for I = 1 A/2 A: $\geq 800,000/500,000$ (at $\sim 250V$ (ohmic load))
<b>Note:</b> If the relays OUT1, 2 and 3 are used to operate external contactors, these must be fitted with RC snubber circuits to manufacturer specifications to prevent excessive voltage peaks at switch-off.	

### 7.2.2. OUT3 as Universal Output

Parallel current/voltage output with common 'minus' terminal (combined use only in galvanically isolated circuits).

Freely scalable resolution:	14 Bit
Dynamic response (step change of input signal) T90:	Output follows the input within 300 ms
Tracking error I/U:	$\leq 2\%$
Residual ripple:	$\leq +1\%$
(rel. to range end)	0...130 kHz
<b>Current output</b>	
0/4...20 mA, configurable, short-circuit proof.	
Control range:	-0.5...23 mA
Load:	$\leq 600\ \Omega$
Load effect:	$\leq 0.02\%$
Resolution:	$\leq 1.5\ \mu A$
Error:	$\leq 0.1\%$
<b>Voltage output</b>	
0/2...10V, configurable, not permanently short-circuit proof	
Control range:	0.15...11.5 V
Load:	$\geq 2\ k\Omega$
Load effect:	$\leq 0.06\%$
Resolution:	$\leq 0.75\ mV$
Error:	$\leq 0.1\%$
Additional error when using simultaneously the current output	$\leq +0.09\%$

### 7.3. Galvanic Isolation

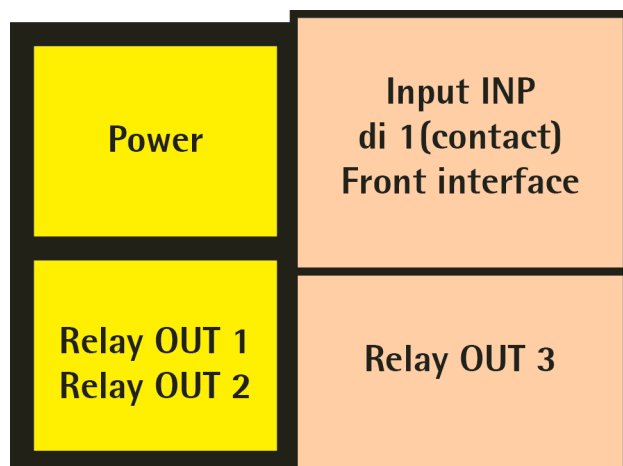

Galvanic isolation between inputs and outputs as well as from the supply voltage is provided.

- Safety isolation
- Functional isolation

Test voltages	
Between power supply and inputs/outputs:	2.3 kV AC, 1 min
Between inputs and outputs:	500 V AC; 1 min
Max. permissible voltages	
Between inputs/outputs against earth:	≤33 V AC

### 7.4. Power Supply

Depending on ordered version:

- AC supply
- Universal supply 24 V UC

#### 7.4.1. AC Supply

Voltage:	90...260 V AC
Frequency:	48...62 Hz
Consumption:	max. 11.5 VA

#### 7.4.2. Universal supply 24 V UC

AC supply:	18...30 V AC
Frequency:	48...62 Hz
DC supply:	18...31 V DC
Consumption:	max. 8.5 VA/5.8 W

supply only via safety-low low voltage (SELV)

#### 7.4.3. Behaviour with power failure

Configuration and parameter settings: Permanent storage in EEPROM.

## 7.5. Engineering Front Interface

Connection to the controller front via a PC adapter (see 'Additional Accessories'). The Engineering software enables the MP 26 to be configured, parameters set, and operated.

## 7.6. Environmental Conditions

### 7.6.1. Protection mode

Front panel:	IP 20
Housing:	IP 20
Terminals:	IP 20

### 7.6.2. Permissible temperatures

For specified accuracy:	-10...55°C
Warm-up time:	≤20 minutes
Temperature effect:	≤0.08 %/10 K
Operating limits:	-20...60°C
Storage:	-30...70°C

### 7.6.3. Humidity

Max. 95 %, 75 % yearly average, no condensation

### 7.6.4. Shock and vibration

<b>Vibration test Fc (DIN EN 60 068-2-6)</b>	
Frequency:	10...150 Hz
Unit in operation:	1 g or 0.075 mm
Unit not in operation:	2 g or 0.15 mm
<b>Shock test Ea (DIN EN 60 068-2-27)</b>	
Shock:	15 g
Duration:	11 ms

### 7.6.5. Electromagnetic compatibility

Meets the test requirements for instruments in industrial areas.

#### Interference radiation

Within the limits for class A instruments.

#### Immunity to interference

Meets EN 61326-1 for continuous, unattended operation.

## 7.7. General

### 7.7.1. Housing front

Material:	Polyamide PA 6.6
Flammability class:	VO (UL 94)

### 7.7.2. Connecting terminals

Material:	Polyamide PA
Flammability class:	V2 (UL 94) for screw terminals

### 7.7.3. Electrical safety

Complies with EN 61 010-1  
Over-voltage category II  
Contamination degree 2  
operating voltage range 300 V  
Protection class II

### 7.7.4. Certifications

CE certified

### 7.7.5. Electrical connections

Plug-in connector strips with choice of terminal type:  
Screw terminals for lead cross-sections from 0.2 to 2.5 mm<sup>2</sup>.

### 7.7.6. Mounting method

Clip-on rail mounting (35 mm top-hat rail to EN 50 022).  
Locked by means of metal catch in housing base.  
Close-packed mounting possible.

Mounting position:	vertical
Weight:	0.18 kg

Published by  
Minebea Intec GmbH | Meiendorfer Strasse 205 A | 22145 Hamburg, Germany  
Phone: +49.40.67960.303 | Email: [info@minebea-intec.com](mailto:info@minebea-intec.com)  
[www.minebea-intec.com](http://www.minebea-intec.com)

